

Spider

EAC CE 0682

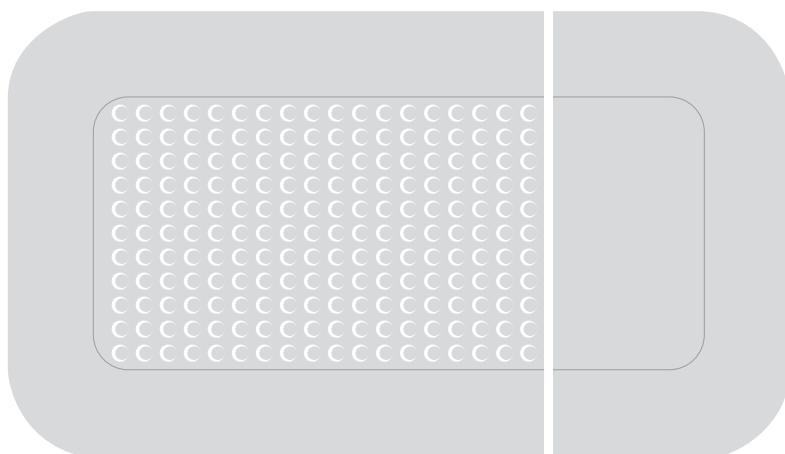

SPIDER800
SPIDER800W
SPIDER1200BLW



Gearmotor for garage doors

EN - Instructions and warnings for installation

Nice

CONTENTS

1	GENERAL SAFETY WARNINGS AND PRECAUTIONS	3	9	TROUBLESHOOTING GUIDE	33
1.1	General warnings	3	9.1	Troubleshooting	33
1.2	Installation warnings	4	9.2	Signalling through warning light	34
2	PRODUCT DESCRIPTION	5	9.3	Signals on the control unit	34
2.1	List of constituent parts	5	9.4	Radio diagnostics	37
3	INSTALLATION	5	10	FURTHER DETAILS (Accessories)	38
3.1	Pre-installation checks	5	10.1	Adding or removing devices	38
3.2	Product usage limits	6	10.1.1	BlueBUS	38
3.3	Product identification and overall dimensions	6	10.1.2	STOP input	38
3.4	Receipt of the product	6	10.1.3	I/O expansion board (optional accessory)	38
3.5	Pre-installation works	7	10.1.4	Learning of other devices	39
3.6	Installing the gearmotor	8	10.1.5	Connecting an SM-type radio receiver (optional accessory)	39
3.7	Manually unlocking and locking the gearmotor	11	10.1.6	Relay photocells with PHOTOTEST function	40
4	ELECTRICAL CONNECTIONS	12	10.1.7	Relay photocells without PHOTOTEST function	41
4.1	Preliminary checks	12	10.1.8	Electric lock	42
4.2	Wiring diagram and description of connections	13	10.2	Connecting and installing the emergency power supply	42
4.2.1	Wiring diagram	13	10.3	Connecting the Oview programmer	43
4.2.2	Description of connections	13	10.4	Connecting other devices	43
4.2.3	Using the control unit buttons	14	11	PARAMETERS AND PROGRAMMABLE FUNCTIONS	44
4.3	Addressing of devices connected with the BlueBUS system	14	11.1	Key to the symbols	44
4.3.1	FT210B photosensor	15	11.2	Common parameters	44
5	FINAL CHECKS AND START-UP	15	11.3	Installation parameters	45
5.1	Power supply connection	15	11.4	Basic parameters	46
5.2	Device learning	16	12	AVAILABLE COMMANDS	51
5.3	Manual programming of the door opening and closing positions	16	12.1	Basic commands	51
5.4	Automatic force search	17	12.2	Extended commands	51
5.5	Checking the door movement	17	13	COMMAND CONFIGURATION	52
5.6	Inverting the direction of motor rotation	18	13.1	Standard configuration	52
6	TESTING AND COMMISSIONING	19	13.2	Configuration of the safety functions	53
6.1	Testing	19	13.3	Control mode description	53
6.2	Commissioning	19	14	INPUT CONFIGURATION	55
7	RADIO PROGRAMMING	20	15	OUTPUT CONFIGURATION	56
7.1	Radio programming description	20	15.1	Control unit output configuration	56
7.1.1	Procedure for memorising transmitter buttons	20	15.2	Output configuration - expansion modules	57
7.2	Verifying transmitter encoding	22	16	TECHNICAL SPECIFICATIONS	59
7.3	Memorisation of a radio command	22	17	CONFORMITY	61
7.3.1	Memorisation in "Mode 1"	22	18	PRODUCT MAINTENANCE	62
7.3.2	Memorisation in "Mode 2"	23	19	PRODUCT DISPOSAL	62
7.3.3	Memorising a new transmitter "near the receiver"	23	INSTRUCTIONS AND WARNINGS	66	
7.3.4	Memorising a new transmitter using the "enabling code" of an old transmitter already memorised in the receiver	23			
7.4	Deleting a radio command	24			
7.4.1	Deleting a single command associated with a button from the receiver's memory	24			
7.4.2	Deleting the receiver's memory (fully)	24			
7.4.3	Locking (or release) of memorisations carried out with the "near the control unit" procedure and/or through the "enabling code"	25			
8	PROGRAMMING THE CONTROL UNIT	26			
8.1	Using the programming buttons	26			
8.2	Level 1 programming (ON-OFF)	27			
8.2.1	Level 1 programming procedure	27			
8.3	Level 2 programming (adjustable parameters)	28			
8.3.1	Level 2 programming procedure	28			
8.4	Special functions	30			
8.4.1	"Always open" function	30			
8.4.2	"Move anyway" function	30			
8.4.3	"Maintenance notice" function	30			
8.4.4	"Maintenance reset" function	30			
8.4.5	"Realignment" function	30			
8.5	Wi-Fi connection	30			
8.5.1	Integrated Wi-Fi module (depending on the version)	30			
8.5.2	BiDi-Wi-Fi interface	31			
8.6	Connecting the Pro-View	32			
8.7	Z-Wave™	32			
8.8	Memory deletion	32			

1.1 GENERAL WARNINGS



WARNING! Important safety instructions. Observe all the instructions as improper installation may cause serious damages.



WARNING! Important safety instructions. It is important to comply with these instructions to ensure personal safety. Store these instructions carefully.



According to the latest European legislation, an automated device must be constructed in conformity to the harmonised rules specified in the current Machinery Directive, which allow for declaring the presumed conformity of the automation. Consequently, all the operations for connecting the product to the mains electricity, its commissioning and maintenance must be carried out exclusively by a qualified and expert technician.



In order to avoid any danger from inadvertent resetting of the thermal cut-off device, this appliance must not be powered through an external switching device, such as a timer, or connected to a supply that is regularly powered or switched off by the circuit.



Permanently affix a label or sign to the door with the following image (minimum height 60 mm) "Figure 1"

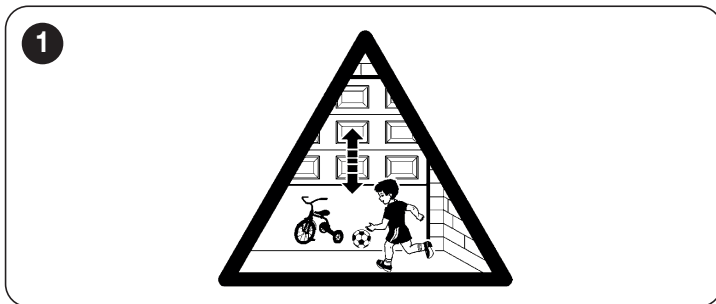

WARNING! Please abide by the following warnings:

- Before commencing the installation, check the "Product technical specifications", in particular whether this product is suitable for automating your guided part. Should it not be suitable, do NOT proceed with the installation.
- The product cannot be used before it has been commissioned as specified in the "Testing and commissioning" chapter.
- Before proceeding with the product's installation, check that all the materials are in good working order and suited to the intended applications.
- The product is not intended for use by persons (including children) with reduced physical, sensory or mental capacities, nor by anyone lacking sufficient experience or familiarity with the product.
- Children must not play with the appliance.
- Do not allow children to play with the product's control devices. Keep the remote controls out of reach of children.

- The system's power supply network must include a disconnection device (not supplied) with a contact opening gap permitting complete disconnection under the conditions envisaged by Overvoltage Category III.
- Handle the product with care during installation, taking care to avoid crushing, denting or dropping it, or allowing contact with liquids of any kind. Keep the product away from sources of heat and naked flames. Failure to observe the above can damage the product, and increase the risk of danger or malfunction. Should this happen, stop installation immediately and contact Customer Service.
- The manufacturer declines all liability for damages to property, objects or people resulting from failure to observe the assembly instructions. In such cases, the warranty for material defects shall not apply.
- The weighted sound pressure level of the emission A is lower than 70 dB(A).
- Cleaning and maintenance reserved for the user must not be carried out by unsupervised children.
- Before intervening on the system (maintenance, cleaning), always disconnect the product from the mains power supply and from any batteries.
- Inspect the system frequently, in particular the cables, springs and supports to detect any imbalances and signs of wear or damage. Do not use the product if it needs to be repaired or adjusted, because defective installation or incorrect balancing of the automation can lead to injuries.
- The packing materials of the product must be disposed of in compliance with local regulations.
- The product must not be installed outdoors.
- Keep an eye on moving doors and do not let anyone go near them until they have opened or closed fully.
- Be careful when activating the manual unlocking device (manual manoeuvre), as an open door may fall suddenly due to weak or broken springs, or if it is unbalanced.
- Every month, check that the drive motor reverses when the door encounters a 50 mm-high object placed on the ground. If necessary, readjust the door and check it again, as incorrect adjustment is potentially dangerous (for drive motors incorporating a trapping safety system that intervenes when the door's lower edge encounters an obstacle).
- If the power cable is damaged, it **must be replaced** by the manufacturer or by its technical assistance service or similarly qualified person in order to prevent any form of risk.



Warning! If there is an automatic door, it could operate unexpectedly; therefore, do not allow anything to hinder the door's path.



Disconnect the power supply during cleaning or maintenance operations.



The automation must not be used with a door that incorporates a pedestrian door (unless the automation can be controlled with the pedestrian door inserted).



After the installation, make sure that the anti-entanglement protection system works as intended.

1.2 INSTALLATION WARNINGS

- Prior to installing the drive motor, check that the door is in good working order, correctly balanced and that it opens and closes properly.
- Before installing the drive motor, remove all unnecessary ropes or chains and deactivate any equipment not required for motorised operation, such as locking devices.
- Install the manoeuvre device for manual unlocking at less than 1.8 m above the ground. NOTE - If removable, the manoeuvre device must be kept next to the door when removed.
- Make sure that the control elements are kept far from moving parts but nonetheless directly within sight. Unless a selector is used, the control elements must be installed at least 1.5 m above the ground and must not be accessible.
- Permanently attach the trapping hazard warning labels in a highly visible location or near the fixed control devices (if present).
- Permanently attach the manual unlock (manual manoeuvre) label close to the manoeuvring element.
- After installation, make sure that the motor prevents or stops opening of the door when the latter is loaded with a 20-kg weight secured to the centre of its bottom edge (for drive motors that can be used with doors having opening widths exceeding 50 mm).
- WARNING! After installation, make sure that the mechanism is properly adjusted and that the motor reverses when the door collides with a 50 mm-tall object placed on the ground (for drive motors incorporating a trapping safety system that intervenes when the bottom edge of the door encounters an obstacle). Following installation, check and ensure that no door parts obstruct public roadways or pavements.

Battery-operated appliances

- The appliance must be disconnected from the power supply when removing the batteries.
- The batteries must be removed from the appliance prior to its disposal.
- The batteries must be safely disposed of.
- If the batteries are not rechargeable, do not replace them with rechargeable batteries.

Appliances with LED light

- Looking at LED lights from close up and for prolonged periods can cause dazzling. It may temporarily reduce eyesight and cause accidents.
- Avoid looking at LEDs directly.

Appliances with radio device

- The manufacturer of this appliance, Nice S.p.A., hereby declares that the product complies with Directive 2014/53/EU.
- The instruction manual and the full text of the EU Declaration of Conformity are available at the following Internet address: www.niceforyou.com, under the "support" and "download" sections
- For transmitters: 433 MHz: ERP < 10 dBm - 868 MHz: ERP < 14 dBm; for receivers: 433 MHz, 868 MHz.

2 PRODUCT DESCRIPTION

SPIDER is an electromechanical actuator for automating sectional doors and protruding and non-protruding overhead doors.

For the application with non-protruding overhead doors, or protruding overhead doors without springs, it is necessary to use the SPA5 accessory, which is not supplied.

The SPA5 accessory is not necessary in the event of spring-based balancing.

The control unit supplied with the product, besides powering the DC motor, ensures optimal adjustment of the gearmotor torque and speed, precise measurement of the positions, gradual starting and closing, and obstacle detection. It is also equipped with an internal meter which allows for recording of the manoeuvres performed by the gearmotor during its lifetime.

The unlocking mechanism, activated from the ground, disengages the motor carriage from the guide.

This product complies with the criteria envisaged in the “Stand-By” regulation. The product enters the Stand-By mode 5 minutes after the end of a manoeuvre that terminated correctly.



CAUTION! – Any use other than that specified herein or in environmental conditions other than those stated in this manual is to be considered improper and is strictly forbidden!

2.1 LIST OF CONSTITUENT PARTS

“Figure 2” shows the main parts making up **SPIDER**.

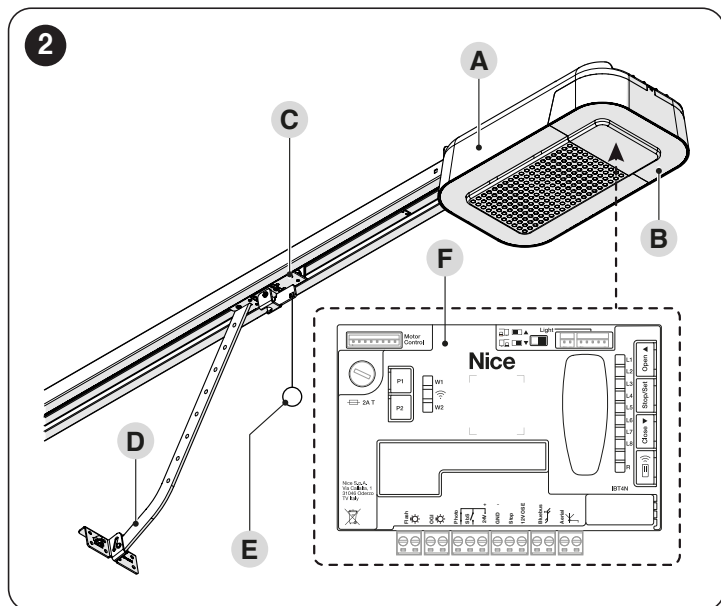

- A** Gearmotor body
- B** Cover
- C** Motor carriage
- D** Drawbar
- E** Locking/unlocking system
- F** Control unit

3 INSTALLATION

3.1 PRE-INSTALLATION CHECKS



The installation must be carried out by qualified personnel in compliance with the current legislation, standards and regulations, and with the instructions provided in this manual.

Before proceeding with the product's installation, it is necessary to:

- check the integrity of the supply
- check that all the materials are in good working order and suited to the intended use
- make sure that the structure of the door is suitable for being automated
- make sure that the characteristics of the door fall within the operating limits specified in the “**Product usage limits**” paragraph (page 6)
- verify that there are no points of greater friction during the opening and closing movements along the entire door path
- verify that the area where the gearmotor is installed allows for unlocking the latter and manoeuvring easily and safely
- Verify that the mounting points of the various devices are protected against impacts and that the mounting surfaces are sufficiently sturdy
- Components must never be immersed in water or other liquids
- Keep the product away from heat sources and open flames and acid, saline or potentially explosive atmospheres; these may damage the product and cause malfunctions or dangerous situations
- Connect the control unit to an electricity supply line equipped with a safety earthing system
- Mount a device on the electric power line that completely disconnects the automation from the grid. The disconnection device must have contacts with a sufficient gap to ensure complete disconnection, under the Category III overvoltage conditions, in accordance with the installation instructions. Should it be necessary, this device guarantees fast and safe disconnection from the power supply; it must therefore be positioned in view of the automation. If placed in a non-visible location, it must have a system that blocks any accidental or unauthorised reconnection of the power supply, in order to prevent dangerous situations. The disconnection device is not supplied with the product.

3.2 PRODUCT USAGE LIMITS

The data relative to the performances of products of the **SPIDER** range are shown in the “**TECHNICAL SPECIFICATIONS**” chapter (page 59) and is the only data that allows for properly assessing whether the product is suitable for its intended use.

The structural features of this product **SPIDER** make them suitable for use on sectional or overhead doors, according to the limits shown in the tables “**Table 1**”, “**Table 2**”, “**Table 3**” and “**Table 4**”

Table 1

OPERATING LIMITS OF SPIDER GEARMOTORS				
Model	Type of guide	Sectional doors	Non-protruding overhead doors (with accessory SPA5)	Protruding overhead doors (with accessory SPA5) or with springs (without SPA5)
SPIDER800 - SPIDER800W	SR32/16	4.4 x 2.6 metres (W x H)	4.2 x 2.4 metres (W x H)	4.2 x 3 metres (W x H)
	SR32/16 + SR08 or SR40	3.4 x 3.4 metres (W x H)	3.1 x 3.4 metres (W x H)	3.6 x 3.6 metres (W x H)
SPIDER1200BLW	SR32/16	6.5 x 2.6 metres (W x H)	6.5 x 2.4 metres (W x H)	6.5 x 3 metres (W x H)
	SR32/16 + SR08 or SR40	5 x 3.4 metres (W x H)	4.9 x 3.4 metres (W x H)	5.6 x 3.6 metres (W x H)

Table 2

LIMITS IN RELATION TO THE HEIGHT OF THE DOOR FOR SPIDER800 - SPIDER800W		
Door height	Maximum no. of cycles/hour	Maximum no. of consecutive cycles
Up to 2 metres	20	10
2-2.5 metres	15	7
2.5-3 metres	12	5
3-3.5 metres	10	4

Table 3

LIMITS IN RELATION TO THE HEIGHT OF THE DOOR FOR SPIDER1200BLW		
Door height	Maximum no. of cycles/hour	Maximum no. of consecutive cycles
Up to 2 metres	40	20
2-2.5 metres	30	14
2.5-3 metres	24	10
3-3.6 metres	20	8

Table 4

LIMITS IN RELATION TO THE FORCE REQUIRED TO MOVE THE DOOR		
Force to move the door	SPIDER800 - SPIDER800W	SPIDER1200BLW
Up to 250 N	25%	15%
250 - 400 N	42%	28%
400 - 500 N	55%	35%
500 - 650 N	70%	45%
650 - 800 N	85%	55%
800 - 100 N	-	70%
1000 - 1200 N	-	85%

The height of the door allows for determining both the maximum number of cycles per hour and the number of consecutive cycles.

The force required to move the door allows for determining the cycle reduction percentage. With a leaf 2.2 metres high, a maximum of 15 cycles/hour and up to 7 consecutive cycles can be completed. If 550 N are required to move the leaf and SPIDER800 or SPIDER800W is used, the cycle must be reduced by 70%. !da duplicazione!

In this case, the maximum cycles/hour amount to 10 and the consecutive cycles are equal to 5.



1 kg = 9.81 N. consequently, for example, 500 N = 51 kg



The control unit is equipped with a manoeuvre limiting device that prevents possible overheating; it is based on the motor load and duration of the cycles, and intervenes when the maximum limit is exceeded.

The measurements shown in “**Table 1**” are purely indicative and are only needed for making a rough estimate. The actual suitability of **SPIDER** for automating a specific door depends on the degree of leaf balancing, guide friction and other aspects, including occasional events such as wind pressure or the presence of frost, which could obstruct the leaf’s movement. To determine the actual conditions, the force required to move the leaf throughout its path must be measured, to ensure that this value does not exceed the “rated torque” specified in the “**TECHNICAL SPECIFICATIONS**” chapter (page 59).



The control unit is equipped with a manoeuvre limiting device that prevents possible overheating; it is based on the motor load and duration of the cycles, and intervenes when the maximum limit is exceeded.

3.3 PRODUCT IDENTIFICATION AND OVERALL DIMENSIONS

The overall dimensions of the product are shown in “**Figure 3**”.

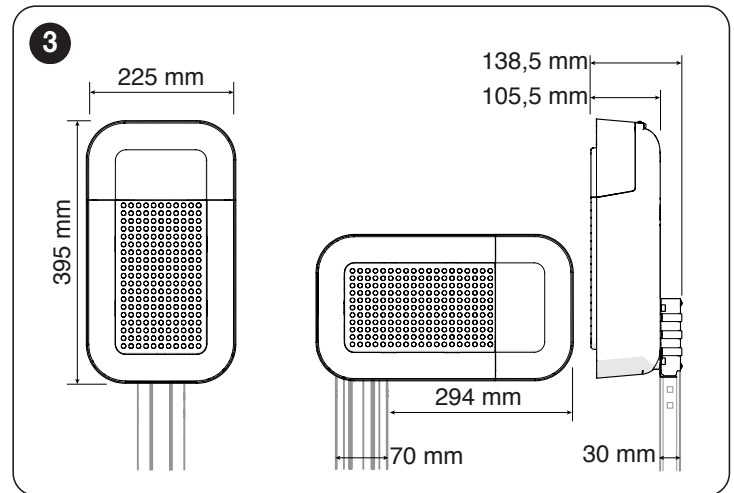

3.4 RECEIPT OF THE PRODUCT

All the components contained in the kit are illustrated and listed below.

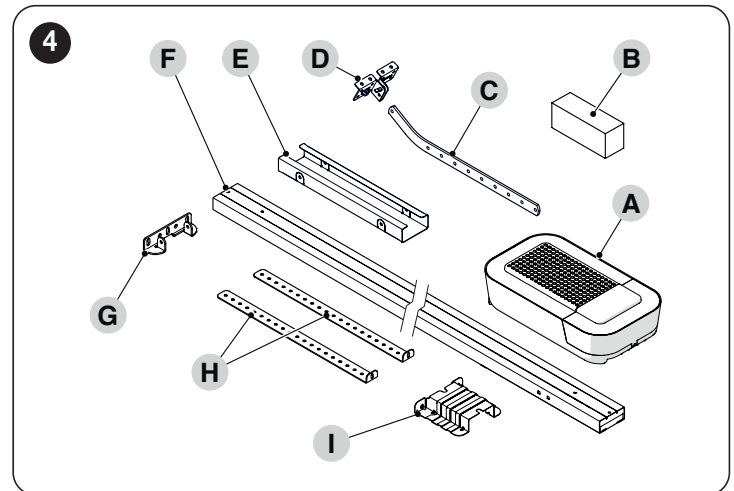

- A** Gearmotor
- B** Unlocking system and metal hardware (screws, washers, etc.)
- C** Drawbar
- D** Door mounting bracket
- E** Joining element for guide (in case of a 2-piece guide)
- F** Assembled / pre-assembled guide
- G** Wall mounting bracket
- H** Ceiling mounting bracket
- I** Motor mounting bracket

3.5 PRE-INSTALLATION WORKS

The figure shows an example of an automation system, constructed using **Nice** components.

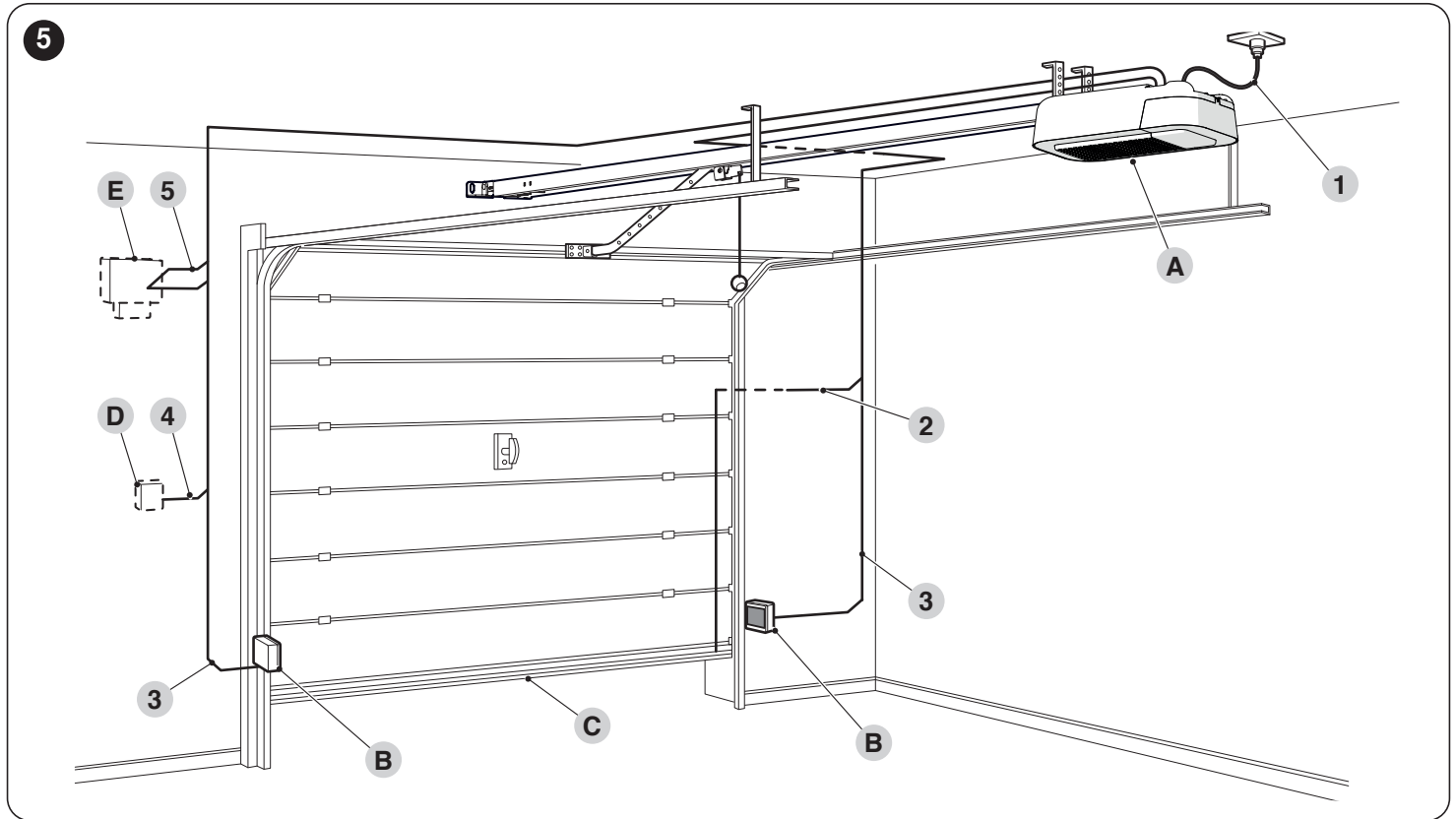

- A** Gearmotor
- B** Photocells
- C** Main edge
- D** Key selector
- E** Warning light with incorporated antenna

The above-mentioned components are positioned according to a typical standard layout. Using the layout shown in “**Figure 5**” for reference, define the approximate position in which each component of the system will be installed.

Table 5

TECHNICAL SPECIFICATIONS OF ELECTRICAL CABLES	
Identification no.	Cable characteristics
1	GEARMOTOR POWER SUPPLY cable 1 cable 3 x 1.5 mm ² Maximum length 30 m [note 1]
2	MAIN EDGE cable 1 cable 2 x 0.5 mm ² Maximum length 20 m
3	PHOTOCELL cable 2 x 0.7 mm ² BlueBus 4 x 0.5 mm ² standard Maximum length 30 m
4	KEY SELECTOR cable 2 cables 2 x 0.5 mm ² [note 2] Maximum length 50 m
5	WARNING LIGHT cable 1 cable 2 x 0.5 mm ² Maximum length 20 m ANTENNA cable 1 x RG58-type shielded cable Maximum length 10 m; recommended < 5 m

Note 1 If the power supply cable is longer than 30 m, a cable with larger cross-sectional area (3 x 2.5 mm²) must be used and a safety earthing system must be installed near the automation.

Note 2 These two cables can be replaced by a single 4 x 0.5 mm² cable.

! Before proceeding with the installation, prepare the required electrical cables by referring to “**Figure 5**” and to that stated in the “**TECHNICAL SPECIFICATIONS**” chapter (page 59).

! The cables used must be suited to the type of environment of the installation site.

! When laying the pipes for routing the electrical cables, take into account that any water deposits in the junction boxes may cause the connection pipes to form condensate inside the control unit, thus damaging the electronic circuits.

“**Figure 6**” shows typical installations for a protruding and non-protruding overhead door.

! For installation on protruding and non-protruding doors, accessory SPA5 is required.

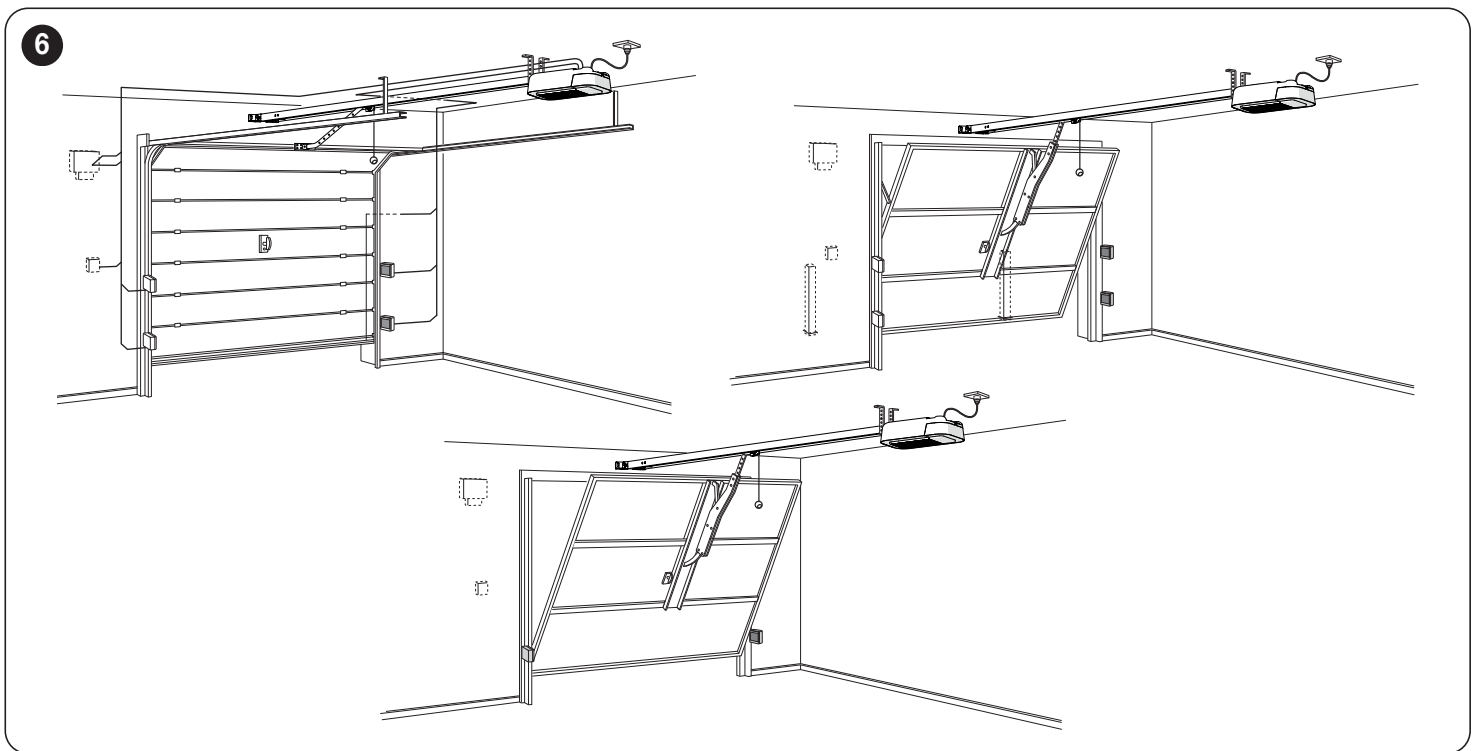

If the door to be automated is an overhead type, check whether distance E in **“Figure 7”** is observed, which refers to the minimum distance between the upper side of the guide and the maximum point reached by the upper edge of the door. If not, the gearmotor cannot be installed.

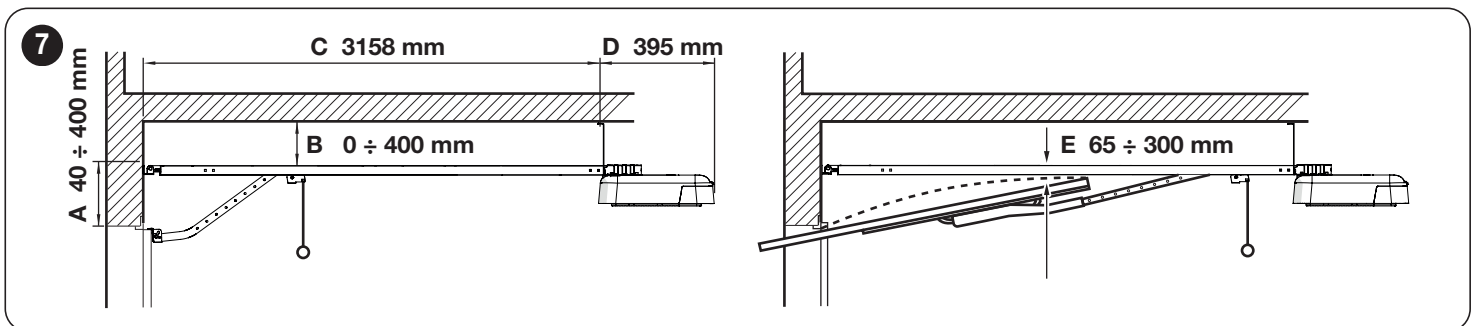

3.6 INSTALLING THE GEARMOTOR

! Incorrect installation may cause serious physical injury to the person working on the system or to its future users.

Before starting to assemble the automation, complete the preliminary checks described in the **“Pre-installation checks”** paragraph (page 5) and the **“Product usage limits”** paragraph (page 6).

! The automation must be installed **EXCLUSIVELY WITH THE DOOR CLOSED.**

! **WARNING!** In this version there are no mechanical stops on the guide

To install **SPIDER**:

1. if you have an entire guide, skip directly to the operations illustrated in **Figure 12**
2. assemble the guide by sliding the two ends (**A**) into the joining element (**B**) until they touch (**“Figure 8”**)

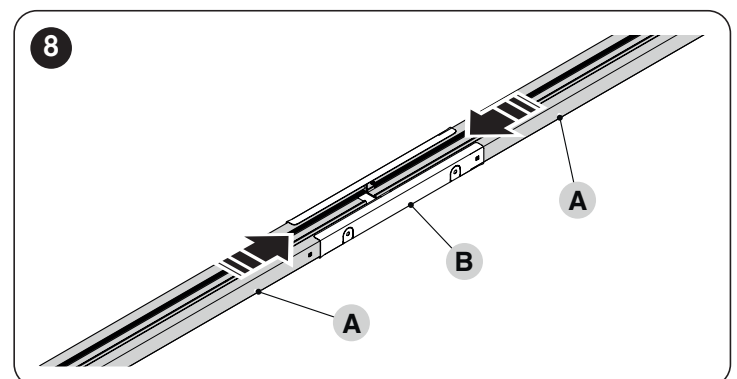

3. If the guide must be fastened in an intermediate position, it is possible to use the 4 tabs (C) present on the joining element. To do this, simply turn the tabs by 90° or 180° (D) ("Figure 9")

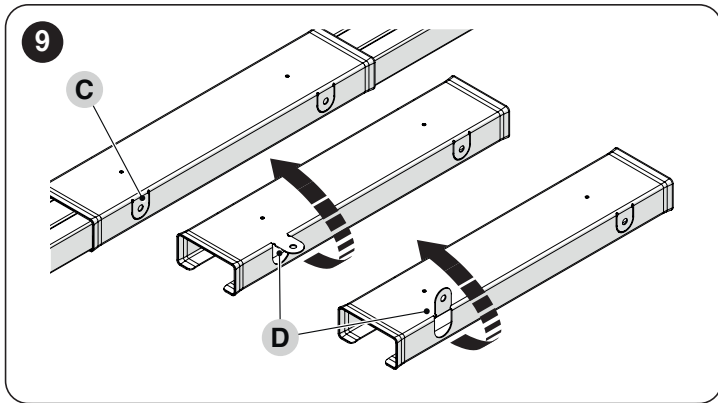

4. insert the bracket (E) into the screw (C) and then make it slide inside the guide
5. insert the spring, washer and nut (F) onto the screw (C) ("Figure 10")

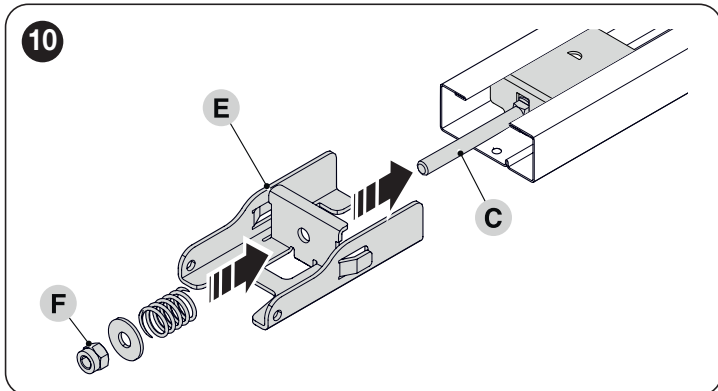

6. slide the head (G) to the end of the guide
7. turn the guide over and lock the head (G) using the screws provided ("Figure 11")

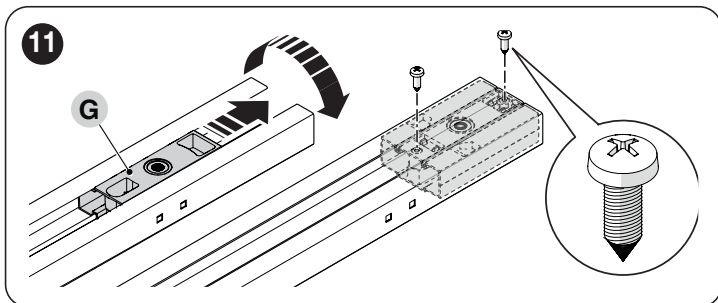

8. turn the nut (F) to tension the belt ("Figure 12")

! An excessively taut belt could cause the gearmotor to break, while an excessively slack belt could cause unpleasant noises.

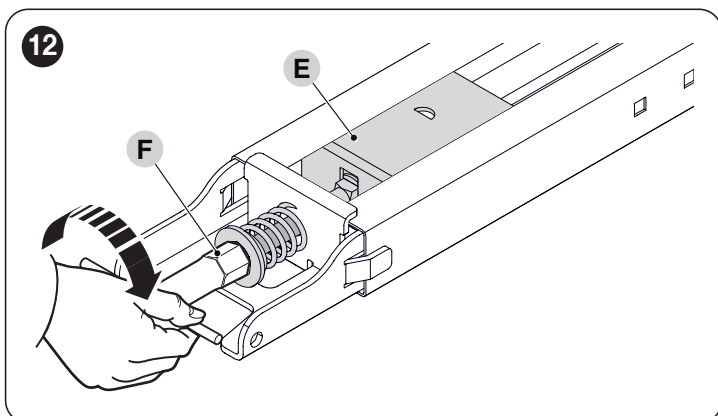

9. insert the motor pin (H) into the head (G)
10. position the drawbar (I) and fasten it with the four screws ("Figure 13")



The motor can also be mounted at 90° with respect to the guide axis.

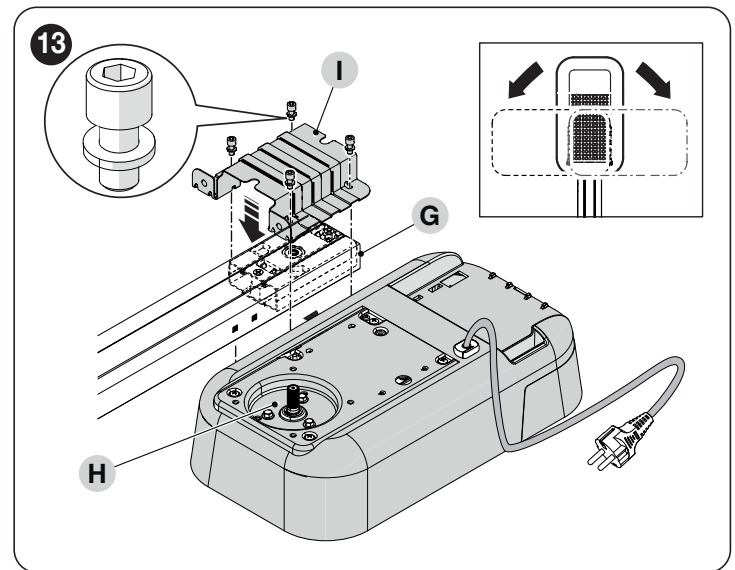

11. from the opening side of the door, position the wall mounting bracket (J) on the guide and lock it by inserting the pin and cotter pin ("Figure 14")

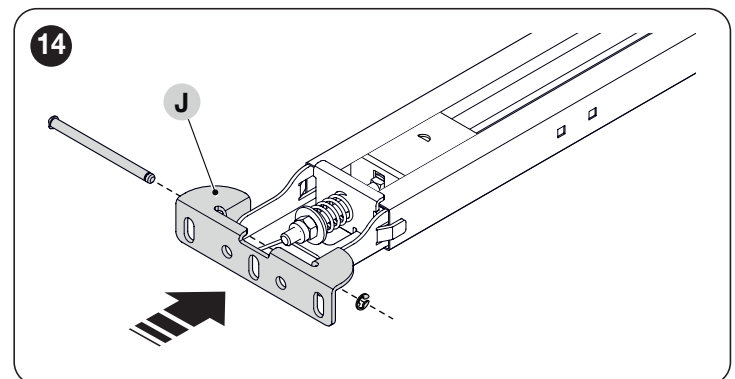

12. mount the door mounting bracket (K) on the drawbar (L)
13. insert the relevant pin (M) into the drawbar and lock it in place with the cotter pin (N) ("Figure 15")

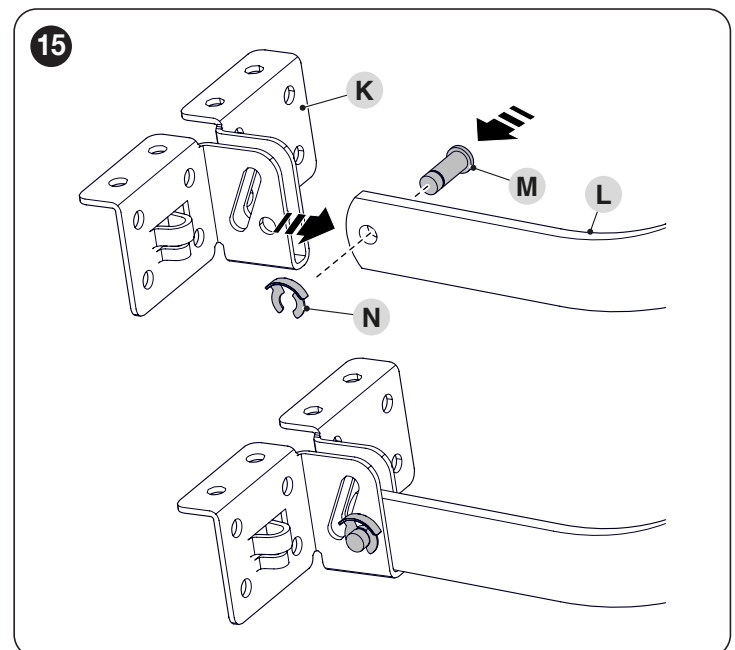

14. mount the pin (O) onto the drawbar (L)
15. attach the drawbar to the motor carriage (P)
16. lock the bracket in place using the two screws ("Figure 16")

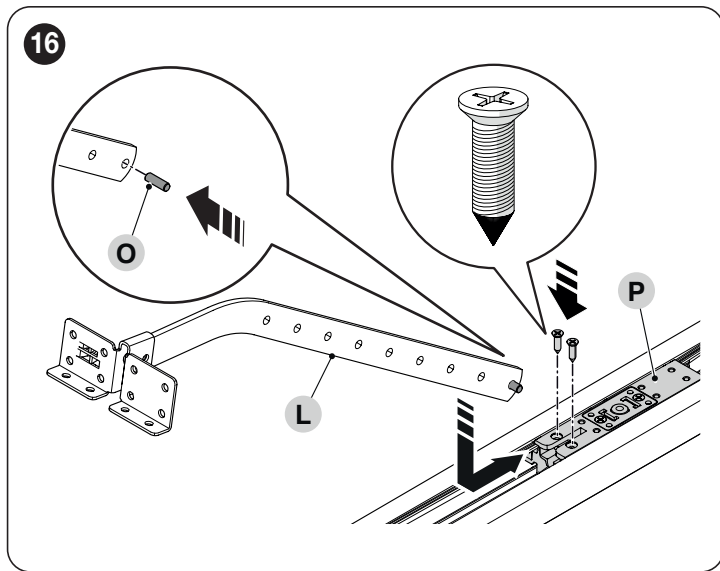

! Verify that the distances chosen for installing the product are compatible with the limit distances (see "Figure 7").

17. fasten the wall mounting bracket (J) to the wall above the door or to the ceiling ("Figure 17")

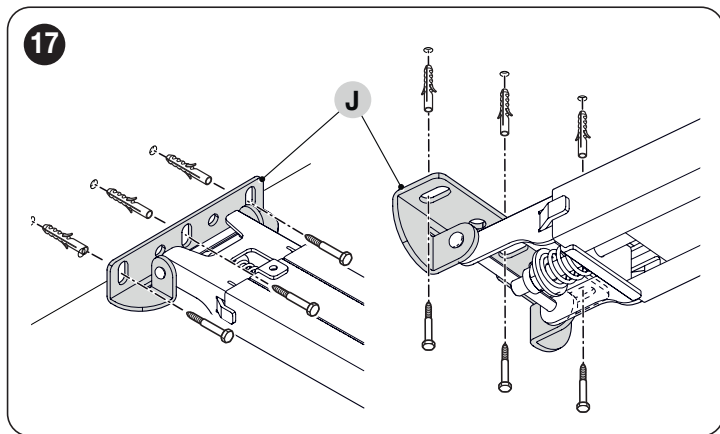

18. use two screws to fasten the ceiling mounting brackets (Q) while observing the desired distance ("Figure 18")

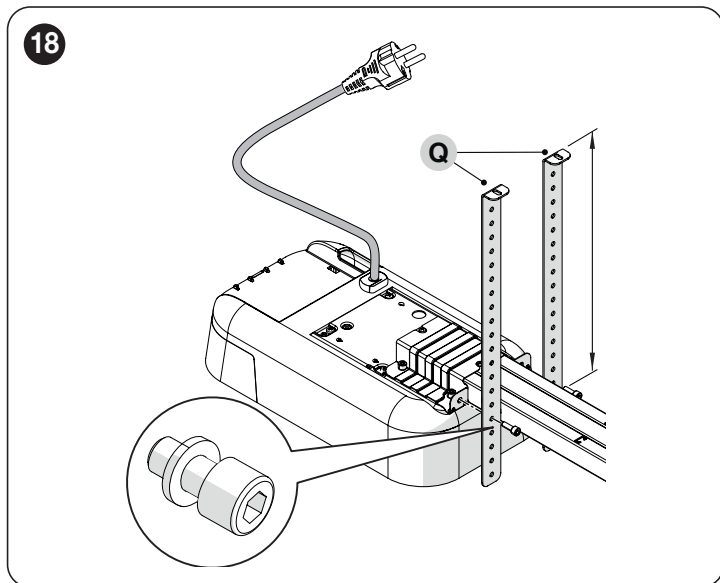

19. using a ladder, lift the gearmotor until the brackets touch the ceiling
20. mark the drilling points and then put the gearmotor back on the ground ("Figure 19")

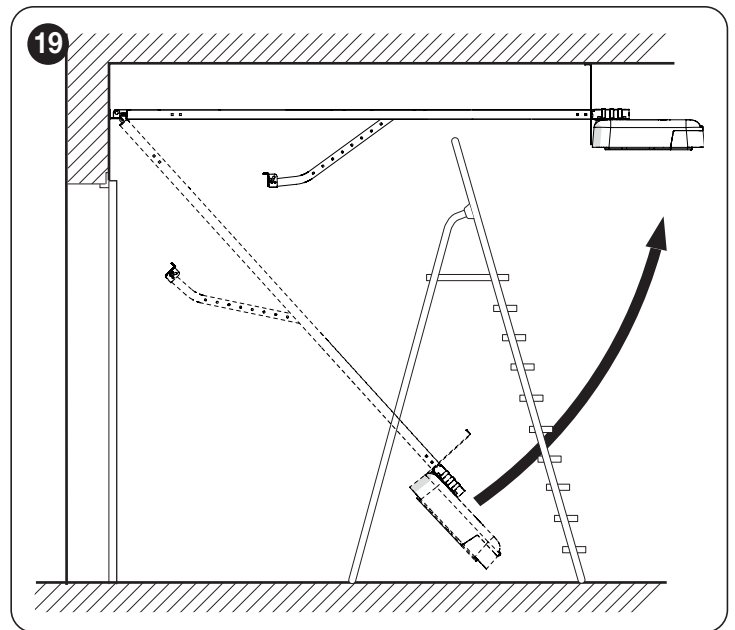

21. drill through the marked points
22. using a ladder, lift the gearmotor until the brackets rest against the drilled holes
23. fasten them using screws and plugs suited to the relevant material ("Figure 20")

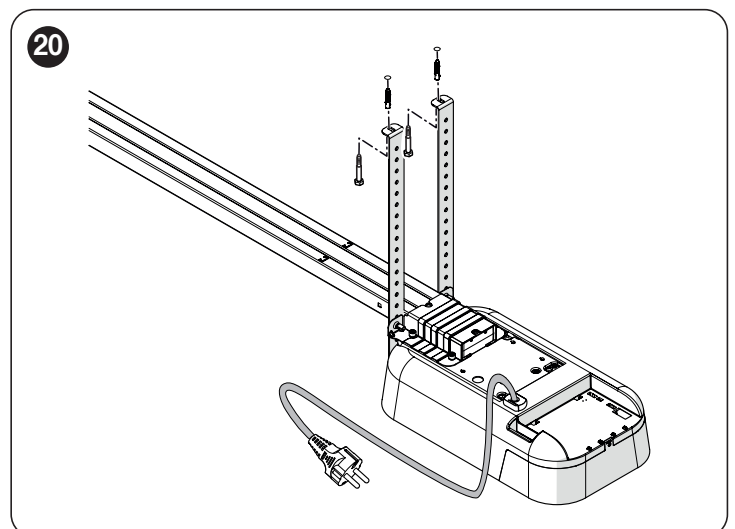

24. ensure that the guide lies perfectly horizontal, then cut off the excess section of the brackets with a saw ("Figure 21")

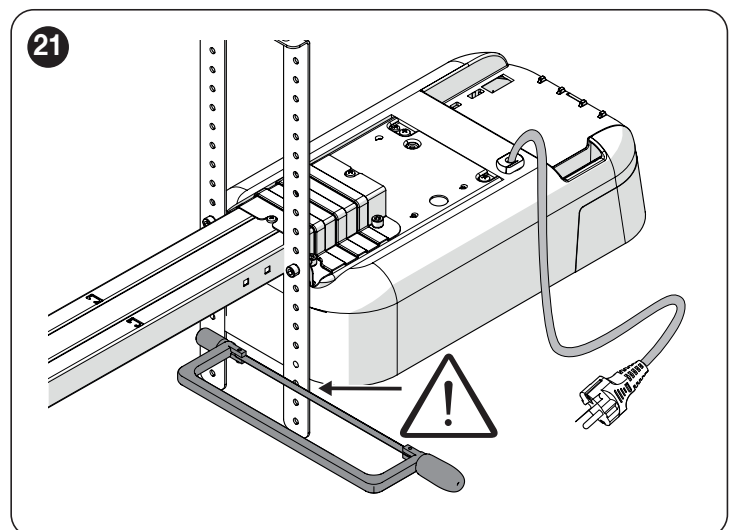

25. assemble the unlocking system (S) by tightening the screw (V) and placing the spring washer (R) in between ("Figure 22")

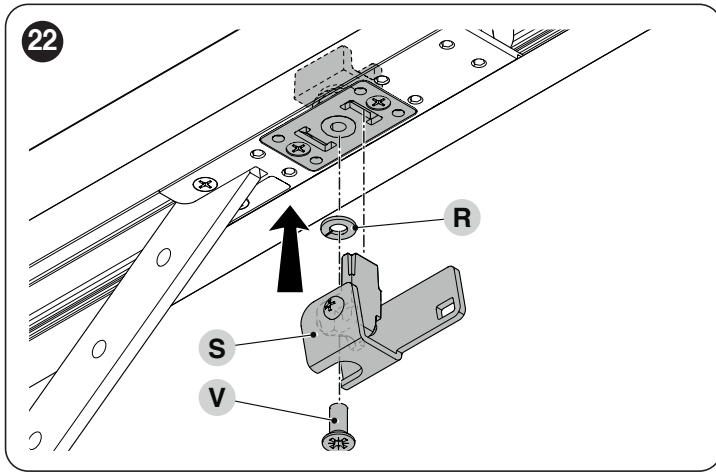

26. fasten the cord (C) and the relevant unlocking ball to the unlocking system (S)
 27. with the door closed, pull the cord (C) to release the carriage ("Figure 23")

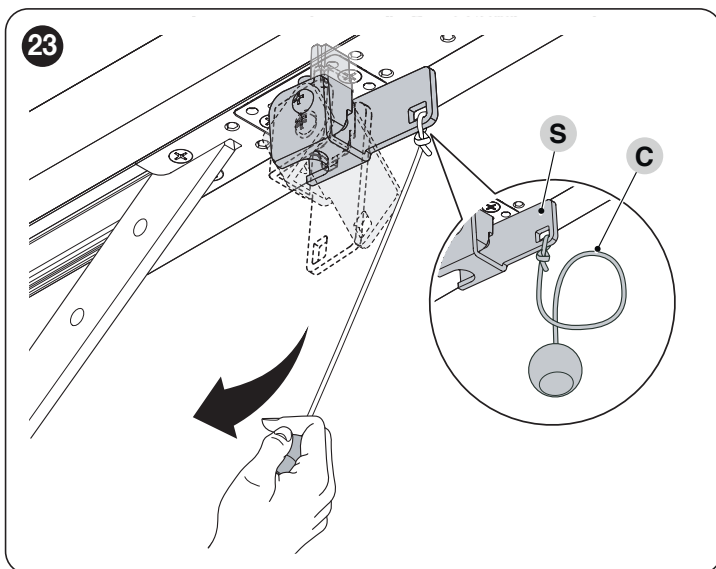

28. slide the motor carriage until the door mounting bracket (K) on the upper edge of the door lies exactly perpendicular to the guide (A)
 29. fasten the bracket (K) using the screws and rivets suited to the door material and the force required to move the door itself ("Figure 24")

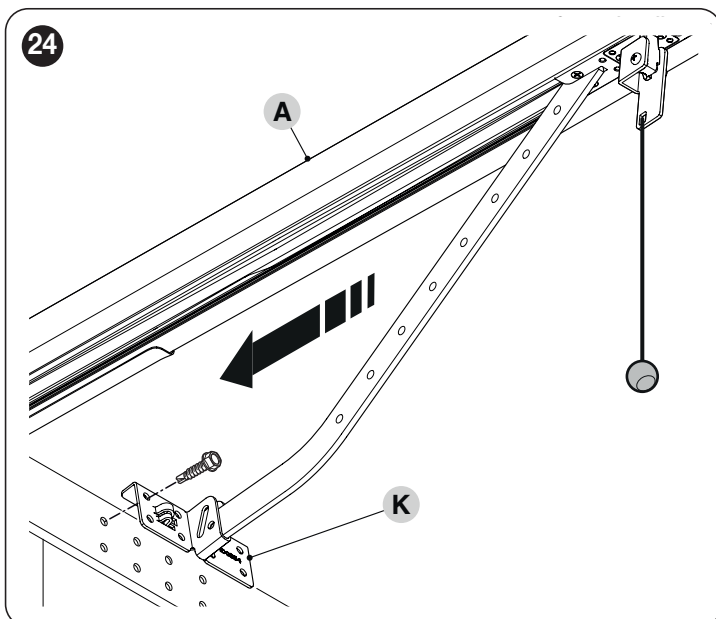

3.7 MANUALLY UNLOCKING AND LOCKING THE GEARMOTOR

The gearmotor is equipped with a mechanical unlocking device that can be used to open and close the door manually. These manual operations should only be performed in case of a power outage, malfunctions or during the installation phases.

To unlock the device:

1. pull the releasing cord (A) ("Figure 25")

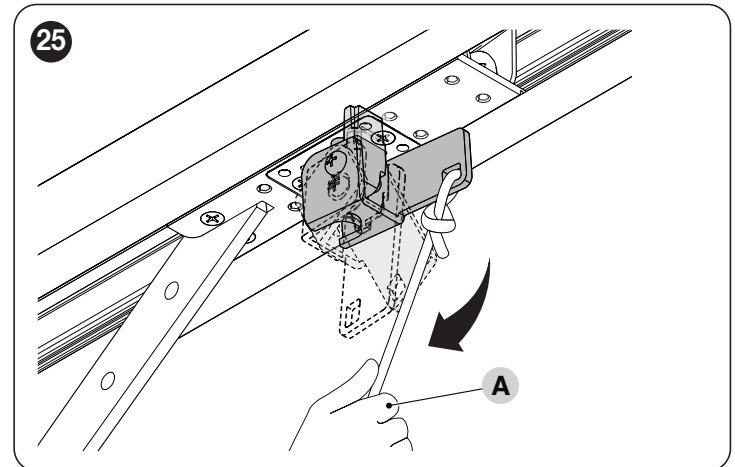

2. the door can now be moved manually to the desired position.

To lock the device:

1. pull the releasing cord (A) ("Figure 26")

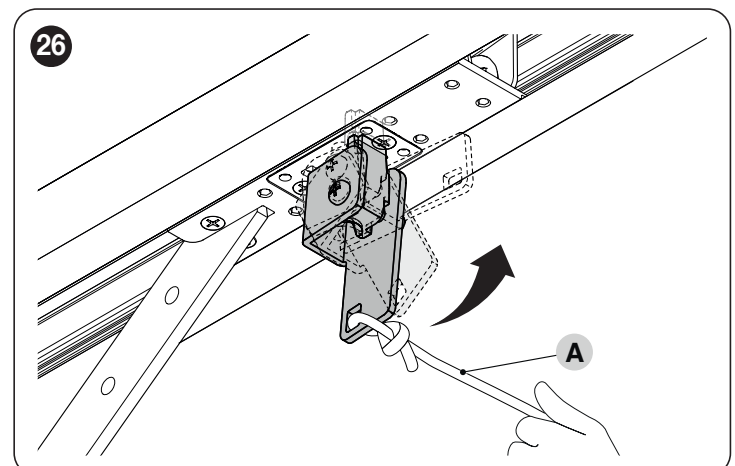

2. manually move the door to align the lower part of the motor carriage with the upper part so that it slots into place.

4 ELECTRICAL CONNECTIONS

4.1 PRELIMINARY CHECKS

 All electrical connections must be made with the system disconnected from the mains electricity and with the emergency power supply (if present in the automation) disconnected.

 The connection operations must only be carried out by qualified personnel.

To make the electrical connections:

1. loosen the screw (A)
2. pull the cover (B) slightly outwards and turn it downwards (**Figure 27**)

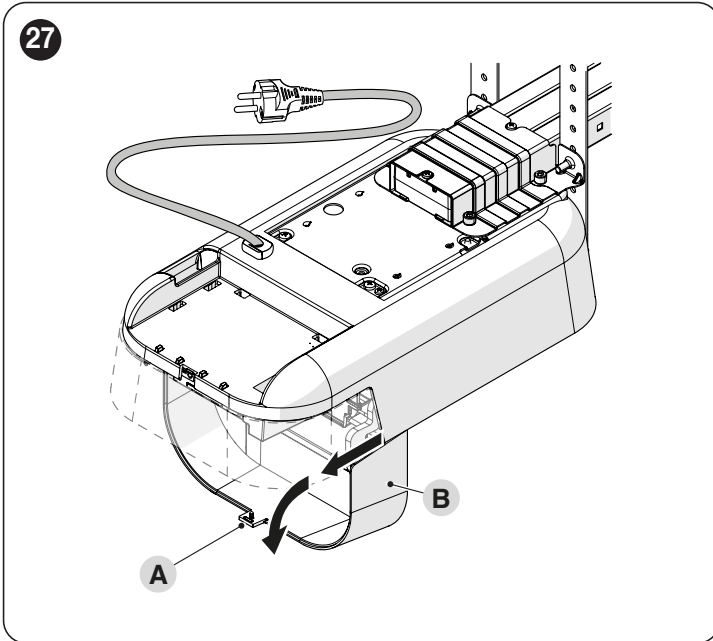

3. insert all the connecting cables into the various devices, leaving them 20–30 cm longer than necessary. Refer to **“Table 5”** for the type of cables and to **“Figure 29”** for the connections.
4. use a cable tie to group all the cables entering the gearmotor (**“Figure 28”**)

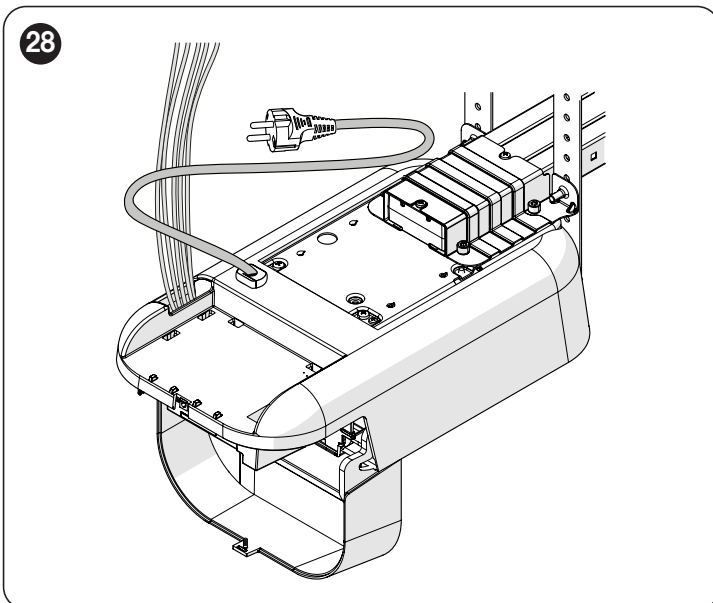

4.2 WIRING DIAGRAM AND DESCRIPTION OF CONNECTIONS

4.2.1 WIRING DIAGRAM

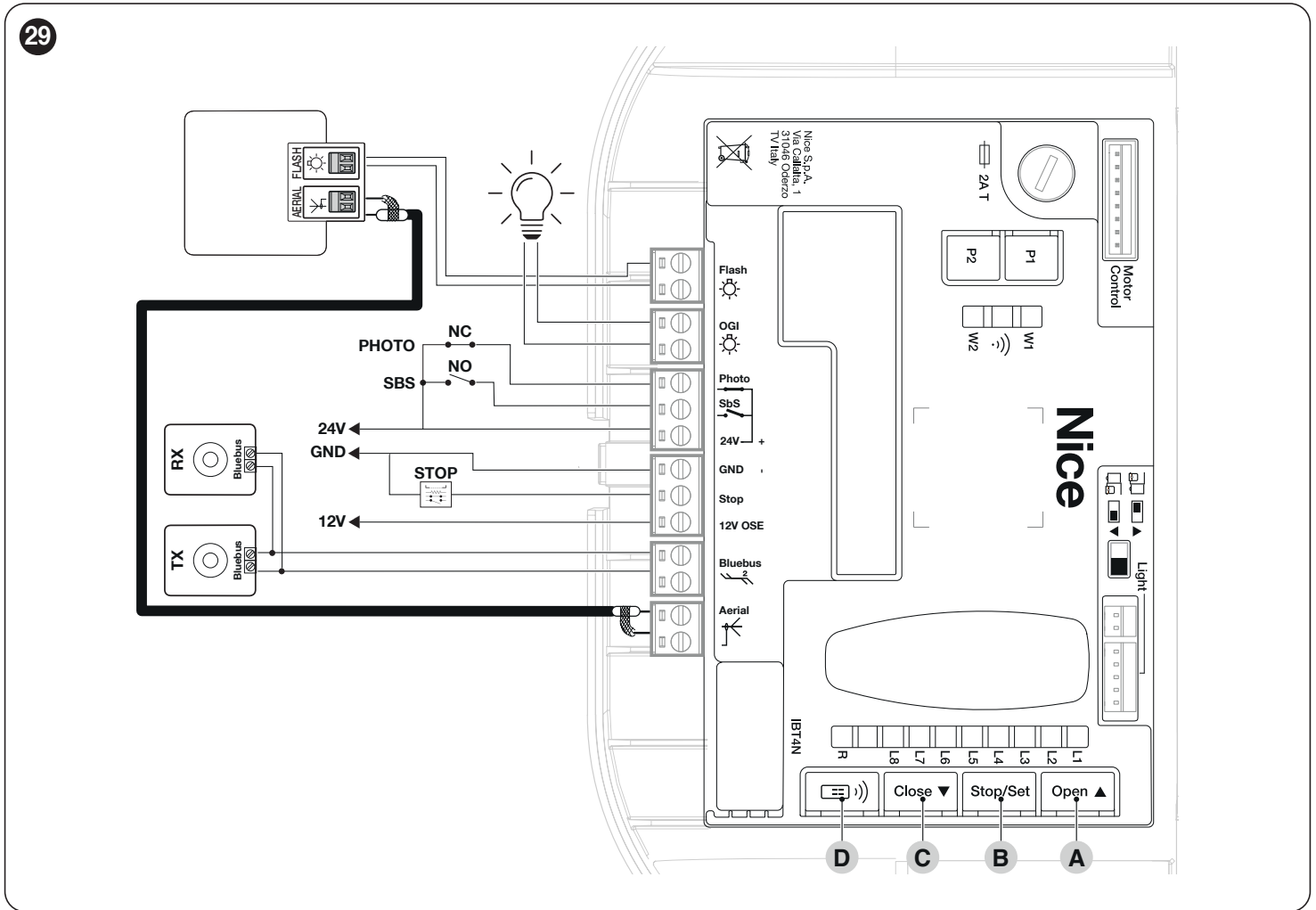

4.2.2 DESCRIPTION OF CONNECTIONS

Table 6

ELECTRICAL CONNECTIONS	
Terminals	Description
FLASH (output limited to 10 W – 24 V)	This output is programmed by default to command a Warning light . The output can be programmed (refer to the “ PROGRAMMING THE CONTROL UNIT ” chapter). The output configuration modes are listed in “ Table 38 ”.
OGI (output limited to 10 W – 24 V)	This output is programmed by default to command the Open Gate Indicator . The output can be programmed (refer to the “ PROGRAMMING THE CONTROL UNIT ” chapter). The output configuration modes are listed in “ Table 39 ”.
BLUEBUS	This terminal can be used to connect compatible devices, which are all connected in parallel with only two wires carrying both the electric power and communication signals. For further information on the BlueBUS, refer to the “ Addressing of devices connected with the BlueBUS system ” paragraph.
STOP	Input for the devices that block or, if necessary, stop the manoeuvre under way. With suitable arrangements, “Normally Closed” or “Normally Open” contacts, or fixed resistor or optical devices can be connected to the input (refer to the “ STOP input ” paragraph).
SbS	Input for devices that control the movement in Step-by-Step mode; it is possible to connect “Normally Open” contacts.
PHOTO	Input for safety devices: it is possible to connect “Normally Closed” contacts to this input.
ANTENNA	Antenna connection input for radio receiver; the antenna is incorporated in the warning light; alternatively, an external antenna can be used.

4.2.3 USING THE CONTROL UNIT BUTTONS

The control unit has 4 buttons, which behave differently in relation to the current status of the control unit.

OPERATION DURING PROGRAMMING

A [Open ▲]

- scrolls the programming menu forward
- increases by one point the value of the parameter being modified

B [Stop/Set]

- accesses the configuration of the selected parameter
- confirms the selected value of the chosen parameter

C [Close ▼]

- scrolls the programming menu backwards
- decreases by one point the value of the parameter being modified

D [Radio ☺]]]

- not enabled

NORMAL OPERATION

A [Open ▲]

- performs an opening manoeuvre

B [Stop/Set]

- stops the current manoeuvre
- with the motor stationary, it switches the courtesy light off
- if pressed for 3 seconds, the programming menu appears

C [Close ▼]

- performs a closing manoeuvre

D [Radio ☺]]]

- allows for memorising or deleting radio remote controls

4.3 ADDRESSING OF DEVICES CONNECTED WITH THE BLUEBUS SYSTEM

By means of addressing using special jumpers, the "BlueBUS" system enables the user to make the control unit recognise the photocells and assign the correct detection function.

The addressing operation must be done on both the TX and RX photocells (setting the jumpers in the same way), while making sure there are no other pairs of photocells with the same address.

In systems for automated overhead doors, the photocells can be connected as shown in the figure below.

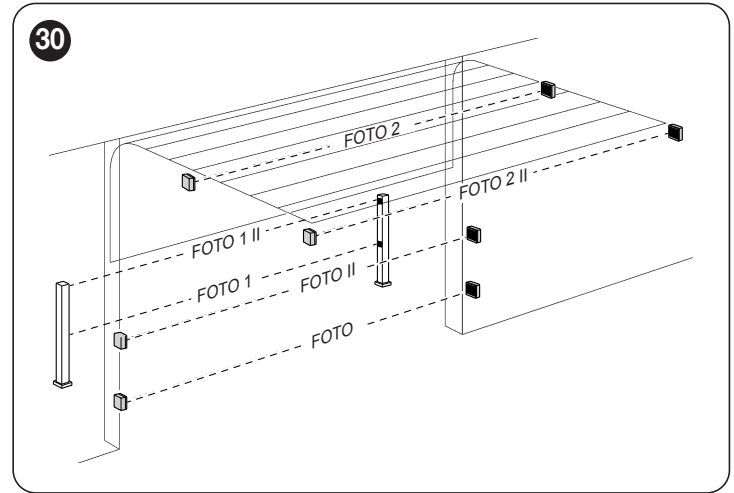

At the end of the installation procedure, or after photocells or other devices have been removed, it is necessary to complete the learning procedure (see the "Device learning" paragraph).



WARNING! Do not place the following photocells adjacent to one another:

PHOTO with PHOTO 2

PHOTO II with PHOTO 3

PHOTO 1 with PHOTO 2 ii

Refer to Table "Table 7" shown below.



By activating Standby, it will not be possible to use BLUEBUS accessories such as keypads, card readers and control photocells.

Table 7

PHOTOCELL ADDRESSES	
Photocell	Position of the jumpers
FOTO (PHOTO) Internal photocell h = 50 cm activated during the closing phase (stops and reverses the gate's movement)	
FOTO II (PHOTO II) Internal photocell h = 100 cm activated during the closing phase (stops and reverses the gate's movement)	
FOTO 1 (PHOTO 1) External photocell h = 50 cm triggered on closing and opening (stops and restarts on opening when the photocell disengages)	
FOTO 1 II (PHOTO 1 II) External photocell h = 100 cm triggered on closing and opening (stops and restarts on opening when the photocell disengages)	
FOTO 2 (PHOTO 2) Internal photocell activated during the opening phase	
FOTO 2 II (PHOTO 2 II) Internal photocell activated during the opening phase	
FOTO 3 (PHOTO 3) Photocell triggered on opening and closing	
FA1 Photocell for opening command (cut jumper A on the back of the TX and RX boards)	
FA2 Photocell for opening command (cut jumper A on the back of the TX and RX boards)	

4.3.1 FT210B PHOTOSENSOR

The FT210B photosensor combines in a single device a force limiting system (type C, in accordance with the EN12453 standard) and a presence sensor that detects obstacles on the line of sight between the TX transmitter and RX receiver (type D, in accordance with the EN12453 standard). In the FT210B photosensor, the signals regarding the status of the sensitive edge are sent through the photocell range, integrating the 2 systems in a single device. The transmitting element located on the moving leaf is battery-powered, which eliminates visually unpleasant connection systems; special circuits reduce battery consumption, ensuring up to 15 years' life (see estimation details in the product's instructions).

A single FT210B device combined with a sensitive edge (TCB65, for example) allows for attaining the level of safety of the "primary edge" required by the EN12453 standard for all "types of use" and "types of activation".

The FT210B photosensor combined with the "resistive" sensitive edges (8.2 kΩ) is safe against faults (category 3 pursuant to the EN 13849-1 standard). It is equipped with a special anti-collision circuit to prevent interference with other detectors, even not synchronised, and allows for adding other photocells; for example, in case of transit of heavy vehicles, where a second photocell is normally positioned 1 m above the ground.



Consult the FT210B instruction manual for further information on the connection and addressing methods.

5 FINAL CHECKS AND START-UP

It is advisable to position the leaf approximately halfway along its path before starting the automation check and start-up phases, so that the leaf is free to open and close.

5.1 POWER SUPPLY CONNECTION



The power supply connections must only be made by qualified and experienced personnel possessing the necessary requirements and in full conformity to the laws, regulations and standards in force.

When starting up the product for the first time, we suggest running a few simple checks:

1. verify that the BlueBUS LED emits a series of 4 RED flashes to indicate the initial start-up and the lack of configuration.
2. make sure that the LEDs on the photocells (both the TX and RX) also flash; the type of flashing is irrelevant, since it depends on other factors.
3. check that the warning light connected to the FLASH output is off.
4. check that the courtesy light is off. The presence of 4 red flashes on the cover must be regarded as normal.
5. verify that the selector is properly positioned: the cursor must be positioned (by default) on the left.

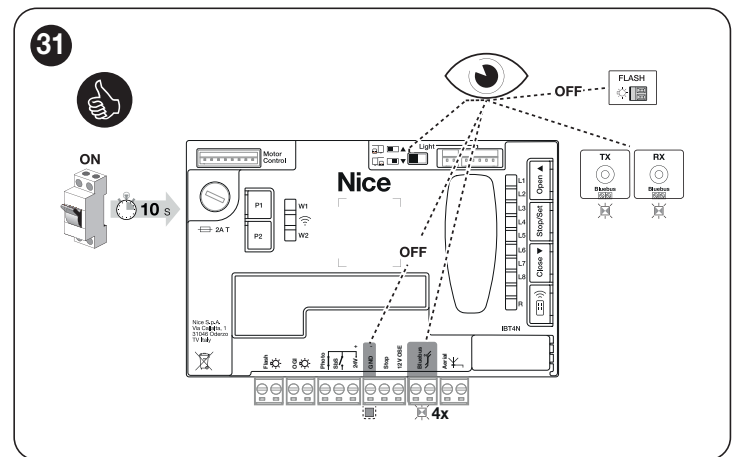

If the above conditions are not satisfied, immediately switch off the power supply to the control unit and carefully check the electrical connections. Further useful information on fault search and diagnosis is included in the "**Troubleshooting**" paragraph (page 33).

5.2 DEVICE LEARNING

After connecting the power supply, the control unit must learn the devices connected to the “BlueBus” and “STOP” inputs, and also the **rotation direction of the motor** set on the selector. Moreover, this procedure recognises and memorises the input and output expansion board connected to the control unit. Before this phase, LEDs “L1” and “L2” will flash to indicate that recognition of the devices must be carried out.



The learning phase must be carried out even if no device is connected to the control unit.

To do this:

1. simultaneously press and hold the [Open ▲] and [Stop/Set] buttons
2. release the buttons when LEDs “L1” and “L2” start flashing quickly (after roughly 3 seconds)
3. wait a few seconds until the control unit has completed the device learning phase
4. once this phase terminates, the “Stop” LED must be lit and LEDs “L1” and “L2” must switch off. In case of initial installation, LEDs “L3” and “L4” will start flashing.

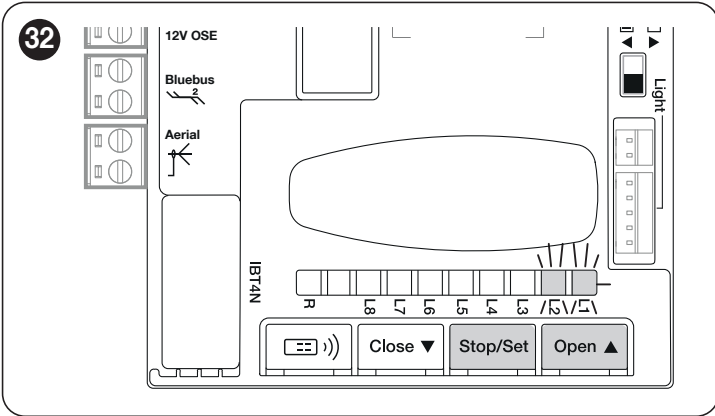

The self-learning phase of the connected devices can be repeated at any time also after the installation, for example whenever a device must be added or removed.



If the motor’s rotation direction must be reversed, the device learning procedure must be performed again. (Refer to the “Inverting the direction of motor rotation” paragraph);

5.3 MANUAL PROGRAMMING OF THE DOOR OPENING AND CLOSING POSITIONS

Once the devices have been learned, the door opening and closing positions must be programmed manually.

If these positions have not yet been memorised (or an invalid), LEDs “L3” and “L4” will flash simultaneously (“Figure 33”).

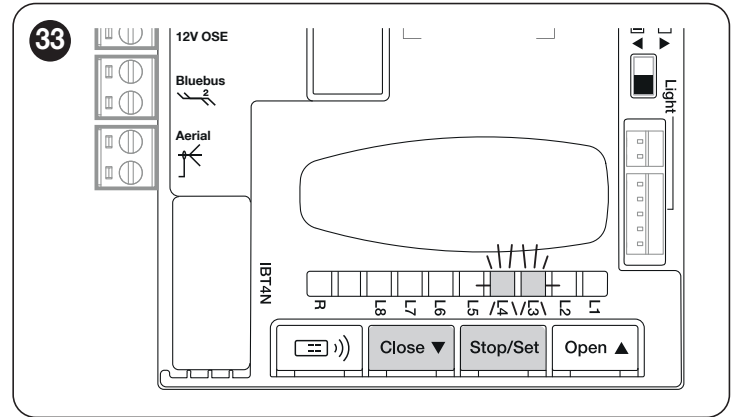

This procedure ensures rapid programming of the opening and closing positions, leaving the control unit to automatically calculate the intermediate positions which can be modified later on through the “myNice Pro” app and the compatible interfaces.

The positions involved in the programming are represented in “Table 8” and shown in Figure “34”.

Table 8

PROGRAMMING POSITIONS		
Position	LED	Description
A1 (max opening)	L1	Maximum desired opening position. When the door reaches this position it stops.
A0 (max closing)	L8	Maximum closing position. When the door reaches this position it stops.

The behaviour of the LEDs in the various programming phases is described in “Table 9”.

Table 9

DESCRIPTION OF THE POSITION PROGRAMMING LEADS	
LED	Description
L1 lit	Opening position saved.
L1 flashing	Programming of the opening position in progress.
L8 lit	Closing position saved.
L8 flashing	Programming of the closing position in progress.

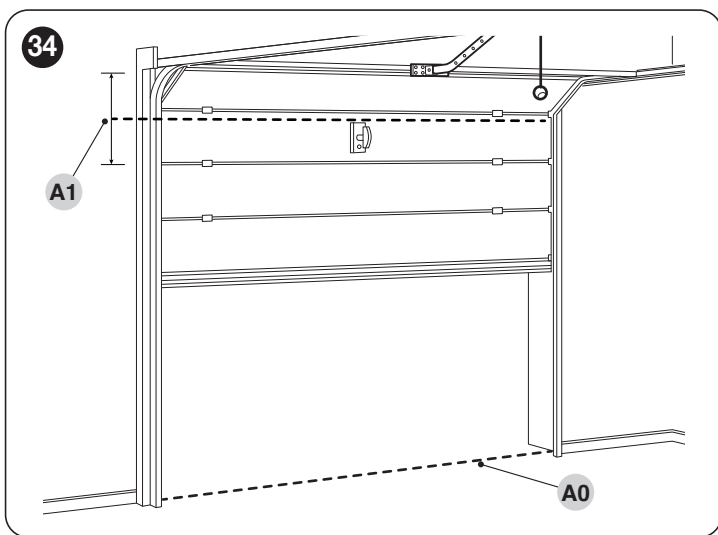

Warning! The position programming procedure (run from the control unit buttons) has a time-out: after starting the programming function, the user has 60 seconds available at every motion command. If no button is pressed within this limit time, the procedure terminates automatically and will have to be restarted from the beginning.

To start the position programming procedure:

1. Press the [Stop/Set] and [Close ▼] buttons for 3 seconds to enter the position programming mode

Maximum opening position programming, LED "L1" flashes:

2. use the [Open ▲] or [Close ▼] button to move the door to the desired opening position
3. press the [Stop/Set] button for 3 seconds to confirm position "A1". LED "L1" will remain lit
4. Release the button

Closing position programming, LED "L8" flashes:

5. use the [Open ▲] and [Close ▼] buttons to move the door to the maximum closing position. **(The closing position must correspond to the point where the door stops on the ground)**
6. press the [Stop/Set] button for 3 seconds to confirm position "A0". LED "L8" will remain lit
7. when the [Stop/Set] button is released, all the LEDs will switch off

Please note: impart a movement command (for example: through the "SbS", "OPEN" inputs) to start the "Automatic Force Search" procedure (refer to the "Automatic force search" paragraph): a complete cycle will be performed. If the above-mentioned procedure is interrupted, it can be restarted by imparting a further "SbS", "Open", "Close" command.

Warning: the programming of the positions can be redone at any time, even after installation; simply repeat the procedure from the beginning.

It is possible to modify the positions calculated autonomously by the control unit, through the "MyNice Pro" app and the Pro-View and BiDi-Wi-Fi interfaces. These can be used to programme the slowdown positions (opening and closing), the partial opening and the exclusion positions. Alternatively, it is possible to use the O-View control unit.

5.4 AUTOMATIC FORCE SEARCH

After a change modifying the values of the positions, the speed settings, the rotation direction or the discharge value, the control unit must start a new "Automatic Force Search" procedure: an opening and closing manoeuvre will be performed automatically to enable the control unit to assess the force required in the successive manoeuvres

During these manoeuvres, check that there are no assembly/adjustment defects or other anomalies, for example points of excessive friction, and solve them if necessary.



The execution of the "Automatic Force Search" procedure is also signalled by the intermittent switching on of the courtesy light during both manoeuvres. During this procedure, the manoeuvres will be carried out with high force.



If there is an interruption in the procedure (STOP intervention, blackout, photocell or control unit intervention), it can be restarted by imparting any type of command (for example: "SbS", "Open", "Close"). Wait for the procedure to then terminate autonomously.

5.5 CHECKING THE DOOR MOVEMENT

Once the leaf length has been learned, it is advisable to carry out a few manoeuvres in order to verify that the door moves properly.

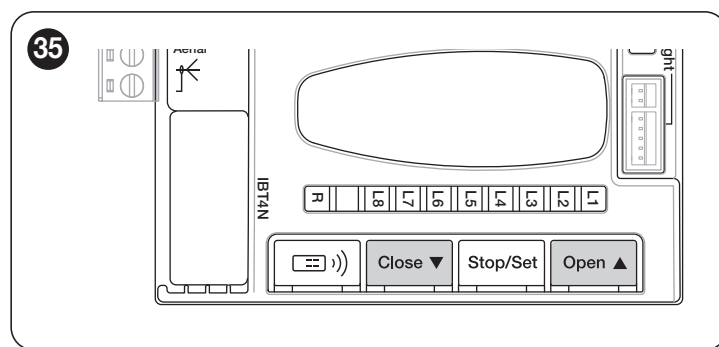

To do this:

1. press the [Open ▲] button to command an "Open" manoeuvre; check that the door opens properly without any speed variations; only when the leaf reaches the slowdown position, it must reach the minimum speed and stop at the "A1" maximum opening position
2. press the [Close ▼] button to command a "Close" manoeuvre; check that the door closes properly without any speed variations; only when the leaf reaches the slowdown position, it must reach the minimum speed and stop at the "A0" maximum closing position
3. during the manoeuvre, check that the warning light flashes at intervals of 0.5 seconds on and 0.5 seconds off (if the FLASH output is configured as default)
4. open and close the gate several times to make sure that there are no points of excessive friction and that there are no defects in the assembly or adjustments
5. check that the gearmotor is fastened in a solid, stable and suitably resistant manner even during sudden door acceleration or slowdown movements.

5.6 INVERTING THE DIRECTION OF MOTOR ROTATION

To modify the rotation direction, simply position selector (A) in the desired direction and start the BlueBus search procedure (refer to the “*Device learning*” chapter on page 16).

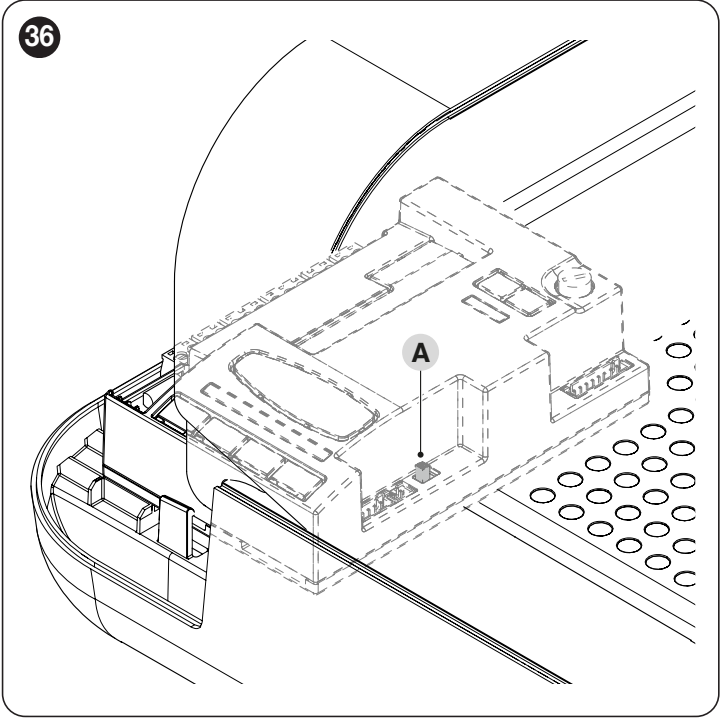

With the selector positioned as shown in **Figure 37** (default setting, typical installation), the automation is opened by moving the door in the direction of the motor. The closing movement occurs towards the ground.

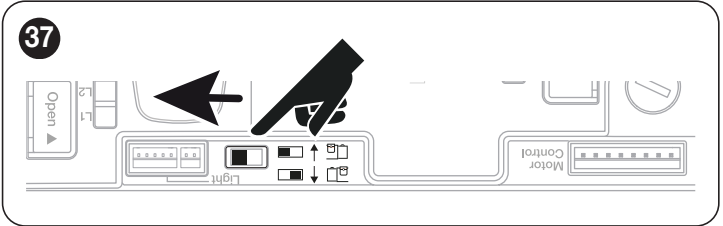

With the selector positioned as shown in **Figure 38**, the automation is opened by moving the door towards the ground. The closing movement occurs towards the motor.

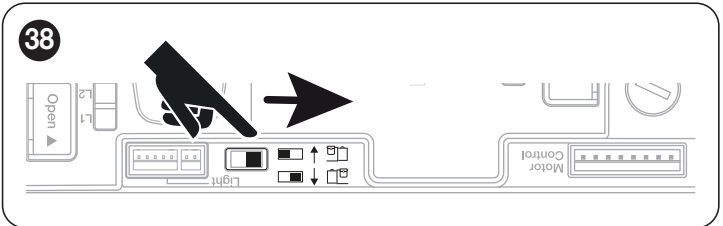

 The change of direction will not be considered until the start of the device acquisition procedure (refer to the “*Device learning*” chapter on page 16).

6 TESTING AND COMMISSIONING

These are the most important phases of the automation's construction, as they ensure maximum safety of the system. The test can also be used to periodically verify the devices making up the automation.

Testing and commissioning of the automation must be performed by skilled and qualified personnel, who are responsible for the tests required to verify the solutions adopted according to the risks present, and for ensuring that all legal provisions, standards and regulations are met, in particular all the requirements of the EN 12453 standard, which defines the test methods for checking door automations.

The additional devices must undergo specific testing, both in terms of their functions and their proper interaction with the control unit. Refer to the instruction manuals of the individual devices.

WARNING! The Stand-By function is active by default. The control unit enters the Stand-By mode, switching off the circuits and reducing consumption, 10 minutes after power-up, if the board is not configured with the positions, and after 5 minutes if it is configured.

6.1 TESTING

To run the test:

1. verify that all the instructions stated in the "**GENERAL SAFETY WARNINGS AND PRECAUTIONS**" chapter (page 3) have been strictly observed
2. unlock the gearmotor as indicated in the "**Manually unlocking and locking the gearmotor**" paragraph (page 11)
3. make sure that the gate can be moved manually during both the opening and closing phases with a force not exceeding 225N (roughly 23 kg)
4. lock the gearmotor
5. using the control devices (selector, radio transmitter, etc.), test the door opening, closing and stoppage phases, ensuring that the movement matches the specifications. Run several tests to check that the door moves smoothly and check for any defects in the assembly or adjustment and any possible points of friction
6. To check the operation of the photocells and ensure that there is no interference with other devices, pass a cylinder (5 cm diameter, 30 cm length) on the optical axis, first near the "**TX**" photocell then near "**RX**" photocell and, lastly, at the mid-point between the two and verify that in all these cases the device is triggered, switching from the active to the alarm status and vice-versa; make sure that it triggers the intended action in the control unit; for example, that it triggers the reversal of movement during the closing manoeuvre.
7. verify the correct operation of all the safety devices present, one by one (photocells, sensitive edges, etc.). If a device intervenes, the "**BlueBus**" LED device on the control unit will emit two quick flashes to confirm the recognition
8. if potentially dangerous situations due to the movement of the leaves have been prevented by limiting the impact force, the latter must be measured according to the EN 12453 standard and, if the "motor force" control is used to aid the system in reducing the impact force, it is necessary to test various adjustments to find the one that gives the best results.

6.2 COMMISSIONING



Commissioning can only be performed after all testing phases have been successfully completed.



Before commissioning the automation, ensure that the owner is properly informed of all residual risks and hazards.



The gate cannot be commissioned partially or under "temporary" conditions.

To commission the automation:

1. compile the automation's technical file, which must include the following documents: overall drawing of the automation, wiring diagram, risk assessment and relative solutions adopted, the manufacturer's declaration of conformity for all devices used and the declaration of conformity compiled by the installer
2. permanently affix a label or plate in the vicinity of the door, indicating the operations for the door unlocking and manual manoeuvres
3. permanently affix a label or sign to the door with the following image (minimum height 60 mm) "**Figure 39**"

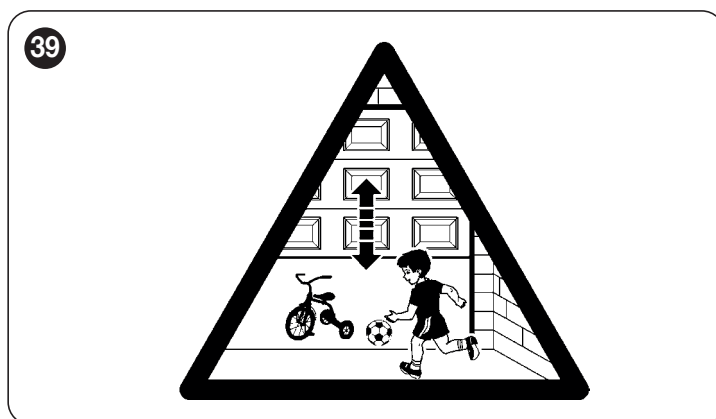

4. affix a label to the door containing at least the following data: type of automation, name and address of manufacturer (person responsible for commissioning), serial number, year of manufacture and the CE mark
5. compile the declaration of conformity of the automation and hand it to the owner of the automation
6. compile the User Manual of the automation and hand it to the owner of the automation
7. compile and provide the owner with the automation's "Maintenance schedule", containing the maintenance instructions for all the automation's devices.



For all the above-mentioned documentation, Nice – through its technical assistance service – provides the following: instruction manuals and guides.

7 RADIO PROGRAMMING

7.1 RADIO PROGRAMMING DESCRIPTION

The control unit has an integrated radio that allows for interacting with the following types of radio remote controls: Unidirectional and Bidirectional. In Unidirectional radio communication, the two devices involved have a clearly defined and unambiguous role within the system: there is a transmitter that sends commands and a receiver that receives and interprets them. The radio communication, therefore, is Unidirectional.

On the other hand, in Bidirectional communication, the two devices (both equipped with Bidirectional radio technology) play a different role each time within the system, as each one is capable of receiving and transmitting information from/to the other device. Therefore, even the transmitters can turn into “receivers” of information coming from the receiver mounted in the control unit.

During the execution of the programming procedures, refer to “**Figure 40**” to identify the radio button **(A)** and LED **R (B)** on the control unit.

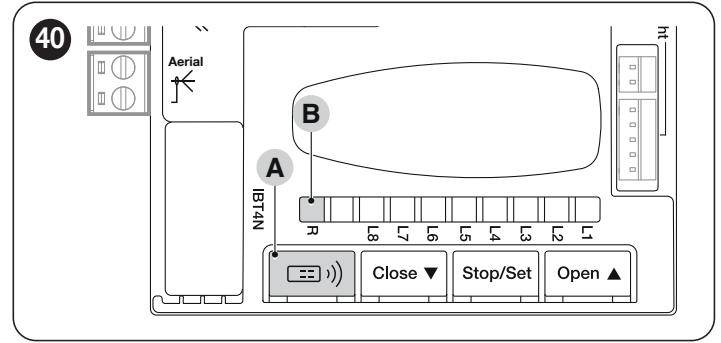

The procedures have a limit time for being performed. Before starting, it is necessary to understand the entire process.

The symbols used in the various programming / deletion procedures with the internal radio module are listed in “**Table 12**”.

7.1.1 PROCEDURE FOR MEMORISING TRANSMITTER BUTTONS

The radio remote controls can be memorised in 2 ways: in “standard” mode (or Mode 1) and in “custom” mode (or Mode 2).

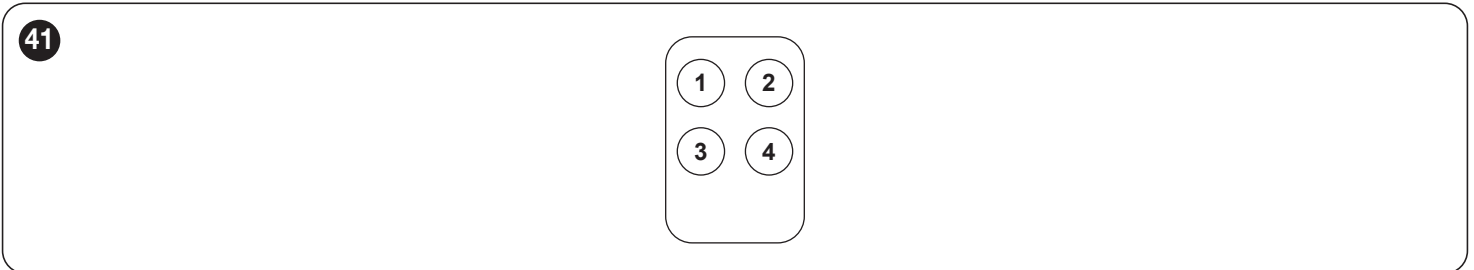

7.1.1.1 STANDARD memorisation (Mode 1: all buttons)

Procedures of this kind allow for simultaneously memorising, during their execution, **all the buttons** on the transmitter. The system automatically associates each button with a pre-defined command, according to the following scheme:

Table 10

TRANSMITTER FUNCTION PAIRINGS	
Command	Button
Step-by-Step	Will be paired with button 1
Partial Open	Will be paired with button 2
OPEN	Will be paired with button 3
CLOSE	Will be paired with button 4

7.1.1.2 CUSTOM memorisation (Mode 2: one button only)

Procedures of this type allow for memorising – during their execution – **a single button** among those present on the transmitter.

The installer decides which button to associate with the command on the basis of the automation’s needs.

For the commands available and the memorisation modes, refer to the modes relevant to the programming of the integrated radio receiver. (refer to the “**RADIO PROGRAMMING**” chapter).

Table 11

OXI / OXIBD / OXIFM / OXIT / OXITFM EXTENDED MODE II		
No.	Command	Description
1	Step-by-Step	“SbS” (Step-by-Step) command
2	Partial open 1	“Partial opening 1” command
3	Open	“Open” command
4	Close	“Close” command
5	Stop	Stops the manoeuvre
6	Condominium Step-by-Step	Command in condominium mode
7	High priority Step-by-Step	Commands also with the automation locked or the commands enabled
8	Partial open 2	Partial open (the door opens up to the position set through Partial Open 2)

OXI / OXIBD / OXIFM / OXIT / OXITFM EXTENDED MODE II

No.	Command	Description
9	Partial open 3	Partial open (the door opens up to the position set through Partial Open 3)
10	Opens and locks the automation	Triggers an opening manoeuvre and, once this terminates, locks the automation; the control unit will not accept any command other than "High-priority Step-by-Step", "Unlock" and "Unlock and close"
11	Closes and locks the automation	Triggers a closing manoeuvre and, once this terminates, locks the automation; the control unit will not accept any command other than "High-priority Step-by-Step", "Unlock" and "Unlock and open"
12	Lock automation	Triggers the stoppage of the manoeuvre and locks the automation; the control unit will not accept any command other than "High-priority Step-by-Step", "Unlock", "Unlock and close" and "Unlock and open"
13	Release automation	Triggers unlocking of the automation and restores normal operation
14	On Timer Courtesy light	Switches on the courtesy light and the output programmed as such in "timer-controlled switch-off" mode
15	On-Off Courtesy light	Switches on the courtesy light and the output programmed as such in "Step-by-Step" mode



PLEASE NOTE: for further details relative to the functions linked to the extractable and integrated radio receivers, consult the website www.niceforyou.com.

Table 12



KEY TO THE SYMBOLS USED IN THE MANUAL

Description	Symbol
LED "R" steady lit	
LED "R" long flashing	
LED "R" fast flashing	
LED "R" off	
Disconnect power supply / Restore power supply (remove fuse F2 and the battery pack – if present)	<p>OFF ON</p>
Wait ...	
Perform the operation within 5 seconds	>5 sec <
Press and hold the radio button on the control unit	
Press and release the radio button on the control unit	
Release the radio button on the control unit	
Press and release the desired transmitter button	
Hold down the desired transmitter button	
Release the desired transmitter button	
Observe when LED "R" emits signals	

7.2 VERIFYING TRANSMITTER ENCODING

To verify to which encoding system the transmitters already memorised in the receiver belong, proceed as explained in the table below:

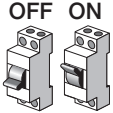
Table 13

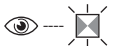
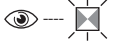
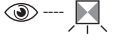
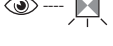
VERIFICATION OF THE TYPE OF ENCODING SYSTEM ADOPTED BY THE TRANSMITTERS ALREADY MEMORISED		
Description	Symbols used	
Disconnect the power supply to the control unit and then restore the power. Count the number of successive flashes:		
2 green flashes = transmitters memorised with O-Code encoding system		X 2
2 green flashes and 1 orange flash = transmitters memorised with O-Code + BD encoding system		X 2+1
5 green flashes = no transmitter memorised		X 5
5 green flashes and 1 orange flash = transmitters memorised with BD technology		X 5+1



7.3 MEMORISATION OF A RADIO COMMAND

7.3.1 MEMORISATION IN "MODE 1"

While the procedure indicated in "Table 14" is being carried out, the receiver memorises all the buttons present on the transmitter, automatically assigning command 1 of the receiver to the 1st button, command 2 to the 2nd button, and so forth.

The memorisation completed will occupy a single memory location.

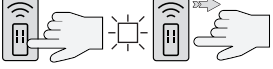
Table 14

MEMORISATION IN MODE 1	
On the control unit	Symbols used
Press and hold the "Radio" button on the control unit and wait for LED "R" to light up green. Release the "Radio" button	
On the transmitter being memorised	
If Unidirectional, press and hold any button within 10 seconds and release it once LED "R" on the control unit emits the 1st of 3 green flashes to confirm the memorisation. (*1)	
If Bidirectional, press and immediately release any button; LED "R" on the control unit will flash green 3 times. The radio remote control will vibrate briefly to confirm the pairing. (*1)	

(*1) - If there are other transmitters to be memorised, repeat the sequence on the transmitter within the next 15 seconds after the first 10 seconds. The procedure will terminate automatically once this time elapses.



To interrupt the procedure immediately (for example, to avoid memorising further radio remote controls), press the "Radio R" button once.



7.3.2 MEMORISATION IN “MODE 2”

During the execution of the procedure indicated in “Table 15”, the receiver memorises a single button among those present on the transmitter, assigning the function chosen by the installer.

To memorise further buttons, repeat the procedure from the beginning for each button to be memorised.

The memorisation will ultimately occupy a single memory location and the command associated with the memorised button will be that chosen by the installer from the “List of commands” of the automation’s control unit (see “Table 11”).

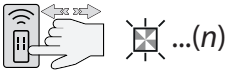
Table 15

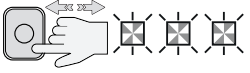
MEMORISATION IN MODE 2 (AND EXTENDED MODE 2)	
On the control unit	Symbols used
Choose the command to be memorised among those listed in “Table 11” and write down the identification number (n).	
Press and release the “Radio” button a number of times equal to the number (n) identifying the chosen command. LED “R” will flash the same number of times.	
On the transmitter being memorised	
If Unidirectional, press and hold the button to be memorised within 10 seconds and release it only once LED “R” on the control unit emits the 1st of 3 green flashes (=memorisation completed correctly). (*2)	
If Bidirectional, press and immediately release the button to be memorised within 10 seconds; LED “R” on the control unit will flash green 3 times. The radio remote control will vibrate briefly to confirm the pairing. (*2)	

(*2) - If there are other transmitters for which the same command must be memorised, repeat the sequence on the button of any additional transmitter within the next 15 seconds after the first 10 seconds. The procedure will terminate automatically once this time elapses.

 **Warning! It is not possible to instantly interrupt the acquisition procedure. If necessary (for example to prevent involuntary pairings), disconnect power fuse F2, wait 30 seconds and then reinsert it.**

7.3.3 MEMORISING A NEW TRANSMITTER “NEAR THE RECEIVER”.



 **Warning! Only for Unidirectional transmitters.**

During the execution of the procedure indicated in “Table 16”, a new transmitter receives the same radio settings of a transmitter already memorised on the control unit.

The procedure does not entail any direct action on the “Radio” button of the control unit, only the presence of the transmitter within the receiver’s reception range.

The memorisation “near the receiver” can be prevented by blocking the receiver’s functions as described in the “**Locking (or release) of memorisations carried out with the “near the control unit” procedure and/or through the “enabling code”**” paragraph.

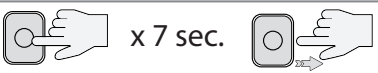
Table 16

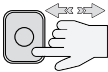
MEMORISING A NEW TRANSMITTER “NEAR THE RECEIVER”	
Description	Symbols used
On the new transmitter press and hold the button to be memorised. Wait 7 seconds and then release it.	
On the transmitter already memorised press slowly and release 3 times the memorised button to be copied.	
On the new transmitter press and release once the same button pressed at the start of the procedure.	

(*2) - If there are other transmitters for which the same command must be memorised, repeat the sequence on the button of any additional transmitter within the next 15 seconds after the first 10 seconds. The procedure will terminate automatically once this time elapses.

7.3.4 MEMORISING A NEW TRANSMITTER USING THE “ENABLING CODE” OF AN OLD TRANSMITTER ALREADY MEMORISED IN THE RECEIVER

 **Warning! Only for transmitters with “O-Code” and “BD” encoding system**

The memory of transmitters with O-Code and BD encoding contains an “enabling code” (secret) which can be used to enable a new transmitter to be memorised in the receiver.

To perform this enabling procedure, read the transmitter’s instruction manual and get an old transmitter already memorised in the same receiver in which the new transmitter is to be memorised.

 **The enabling code can only be transferred between two identical transmitters that have the same radio coding.**

Subsequently, when the new enabled transmitter will be used, it will send to the receiver (in the first 20 transmissions) the command, its own identification code and the “enabling code” received. At this point, the receiver will recognise the enabling code of the old transmitter and automatically memorise the identification code of the new transmitter.

The undesired memorisation of transmitters through the “enabling code” can be prevented by blocking the receiver’s function (refer to the “**Locking (or release) of memorisations carried out with the “near the control unit” procedure and/or through the “enabling code”**” paragraph).

7.4 DELETING A RADIO COMMAND



7.4.1 DELETING A SINGLE COMMAND ASSOCIATED WITH A BUTTON FROM THE RECEIVER'S MEMORY

During the execution of the procedure indicated in "Table 17" it is possible to delete the memorisation of a command associated with a button

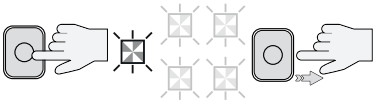

Warning! If the transmitter is memorised in "Mode 1" (refer to the "Memorisation in "Mode 1"" paragraph), during the procedure the entire transmitter is deleted, in other words, all buttons of the radio remote control.

Table 17

DELETING A SINGLE BUTTON FROM THE RECEIVER'S MEMORY	
Description	Symbols used
Press and hold the "Radio" button on the control unit and wait for LED "R" to light up green and switch off. Release the "Radio" button	
On the transmitter to be deleted	
If Unidirectional, press and hold button (*4) to be deleted and release it only once LED "R" on the control unit has emitted the 1st of 5 fast green flashes (=memorisation completed correctly).	
If Bidirectional, press and release the button to be deleted (*4); LED "R" on the control unit will emit 5 fast green flashes (=deletion completed successfully).	





(*4) - If the transmitter is memorised in "Mode 1" (see "Memorisation in "Mode 1""), any button can be pressed. If the transmitter is memorised in "Mode 2" (see "Memorisation in "Mode 2""), the entire procedure must be repeated for each memorised button that must be deleted.

7.4.2 DELETING THE RECEIVER'S MEMORY (FULLY)

In a Unidirectional system, the code deletion procedures involve the receiver alone. In a Bidirectional system, it will instead be necessary to delete the pairing also on the radio remote control.

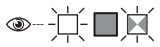
To perform this procedure, consult the instruction manual of the relevant transmitter.

Table 18







FULL DELETION OF THE RECEIVER'S MEMORY.	
Description	Symbols used
Press and hold the "Radio" button on the control unit and wait for LED "R" to light up green and switch off. It will start flashing after a few seconds.	 
Deletion modes	
To delete the receiver's memory, release the "Radio" button precisely at the 5th flash.	 
Wait for LED "R" on the control unit to make 5 rapid flashes. (Deletion completed successfully).	

7.4.3 LOCKING (OR RELEASE) OF MEMORISATIONS CARRIED OUT WITH THE “NEAR THE CONTROL UNIT” PROCEDURE AND/OR THROUGH THE “ENABLING CODE”

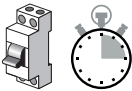
Through the procedure indicated in “**Table 19**”, it is possible to inhibit the memorisation of new transmitters in the receiver when attempting to use the “near the receiver” procedure (see “**Memorising a new transmitter “near the receiver”.**”) or the “enabling code” procedure (see “**Memorising a new transmitter using the “enabling code” of an old transmitter already memorised in the receiver**”)

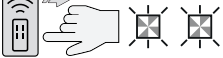
The default setting is “ON” for both procedures. To perform the following procedure it is necessary to have a transmitter already memorised in the receiver.

Table 19

LOCKING (OR RELEASE) OF MEMORISATIONS CARRIED OUT WITH THE “NEAR THE CONTROL UNIT” PROCEDURE AND/OR THROUGH THE “ENABLING CODE”	
Description	Symbols used
Disconnect the power supply by removing fuse F2 and the battery pack (if present). Wait 10 seconds.	OFF 10 s 
Press and hold the “Radio” button and simultaneously restore the power supply.	ON 
LED “R” will first emit signals relative to the memorised transmitters followed by short orange flashes.	
Release the “Radio” button precisely at the end of the second orange flash.	
Within 5 seconds repeatedly press and release the “Radio” button to choose one of the following functions, identifiable by the status of LED “R”:	< 5 sec >
No lock active = LED OFF	
Locking of the memorisation “near the control unit” = RED LED	
Locking of the memorisation with the “enabling code” = GREEN LED	
Locking of both memorisations (“near the control unit” and with “enabling code”) = ORANGE LED	
Within 5 seconds on a transmitter already memorised in the receiver, press and release a button (memorised) to save the function that has just been chosen	

8 PROGRAMMING THE CONTROL UNIT

There are 3 buttons on the control unit: **[Open ▲]**, **[Stop/Set]** and **[Close ▼]** (“**Figure 42**”) which can be used both to command the control unit and to programme the available functions.

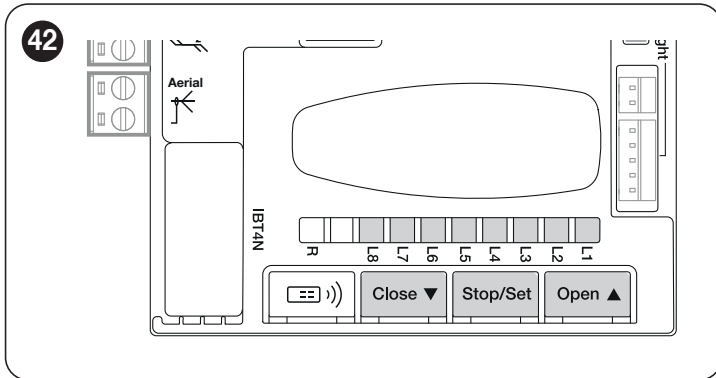

The available programmable functions are grouped into **two levels** and their operating status is signalled by eight LEDs “**L1 ... L8**” located on the control unit (LED lit = function enabled; LED off = function disabled).

8.1 USING THE PROGRAMMING BUTTONS

[Open ▲]

The button allows for commanding the door opening movement, or shifting the programming point upwards.

[Stop/Set]

Button used to stop a manoeuvre.

If pressed for more than 3 seconds, it allows for entering the programming mode.

[Close ▼]

The button enables the user to close the door or shift the programming point downwards.



Warning! During the manoeuvre, whether opening or closing is irrelevant, all the buttons perform the STOP function and stop the motor's movement.

8.2 LEVEL 1 PROGRAMMING (ON-OFF)

All Level 1 functions are factory-set to “OFF” and can be modified at any time. To check the various functions, refer to “Table 20”.

8.2.1 LEVEL 1 PROGRAMMING PROCEDURE



The user has maximum 20 seconds to press the buttons consecutively during the programming procedure. After this time, the procedure terminates automatically and memorises the changes made up to that time.

To perform Level 1 programming:

1. press and hold the [Stop/Set] button until LED “L1” starts flashing
2. release the [Stop/Set] button
3. press the [Open ▲] or [Close ▼] button to move the flashing LED to the LED associated with the function to be modified
4. press and release the [Stop/Set] button immediately to change the status of the function:
 - short flash = OFF
 - long flash = ON
5. wait 20 seconds (maximum time), without pressing any button, to exit the programming mode.



To set other functions to “ON” or “OFF”, while the procedure is running, repeat points 3 and 4 during the phase itself.

Table 20

LEVEL 1 FUNCTIONS (ON-OFF)		
LED	Function	Description
L1	Automatic closing	Function ON: after a complete opening manoeuvre there is a pause (equal to the set pause time), after which the control unit automatically starts a closing manoeuvre. Function OFF: the system works in “semi-automatic” mode.
L2	Close after photo	Function ON: the behaviour changes depending on whether the “Automatic Closing” function is enabled or not. When “Automatic closing” is not active: The door always reaches the fully open position (even if Photo is disengaged beforehand). When Photo disengages, automatic closing is triggered with a 5-second pause. When “Automatic Closing” is enabled: the opening manoeuvre stops immediately after the photocells have disengaged. After 5 seconds, the gate will start closing automatically. The “Close After Photo” function is always disabled in manoeuvres interrupted by a Stop command. Function OFF: the pause time is that which has been programmed or automatic re-closing will not take place if the function is disabled.
L3	Always Close	Function ON: in the event of a blackout, even of short duration, if the control unit detects that the automation is open once the electricity is restored, it automatically starts a closing manoeuvre, preceded by a 5-second pre-flashing sequence. Function OFF: when the power is restored, the automation maintains its current position.
L4	Stand-by	Function ON: This function allows you to reduce consumption. After 5 minutes (programmable time) from the end of each maneuver, the control unit switches off the BlueBUS output and all the LEDs on the control unit (except the BlueBUS LED which will slowly flash green). In this mode all the BlueBUS control devices such as keypads, card readers and control photocells will be switched off and will not work. When the control unit receives a movement command, it restores full operation. This function is particularly useful when operating with a battery backup system. Function OFF: normal operation. Warning! The stand-by function has various modes that can be activated through compatible interfaces. The standby function is active by default as follows: Standby all: products without integrated wifi module (SPIDER800) Standby no wifi: products with integrated wifi (SPIDER800W, SPIDER1200BLW).
L5	Anti-tamper	Function ON: after the closing of the door, if a tampering attempt is detected, a signal is sent to the app and a new closing manoeuvre is forced. Function OFF: normal operation. With the Burglar-proof function active, Standby must be deactivated.
L6	Pre-flashing	Function ON: a 3-second (configurable) pause can be added between the switching on of the warning light and the start of the manoeuvre, to warn the user in advance of a potentially dangerous situation. Function OFF: the signalling of the warning light coincides with the start of the manoeuvre
L7	Deactivate internal radio	Function ON: deactivates the receiver of the radio inside the control unit. Function OFF: normal operation. Warning. Activate this function if you are using a type OXI / OXIBD external receiver.
L8	Light / heavy door mode	Function ON: Configures the control unit with the pre-set parameters (force, sensitivity and speed) optimised for managing a door regarded as “light”. Function OFF: Configures the control unit with the pre-set parameters (force, sensitivity and speed) optimised for managing a door regarded as “heavy”. WARNING: The pre-sets indicated above are modified automatically whenever the parameter setting is modified. When exiting the programming menu, the user will be asked to perform a new force search action 8 (see Automatic force search).

With the motor stationary, LEDs “L1 ... L8” are lit or off depending on the status of the respective function; for example: “L1” is lit when the “Automatic Closing” function is enabled. During the manoeuvre, LEDs “L1 ... L8” flash to signal the force required to move the door at that time.

If “L1” flashes, the force required is low and so forth, until LED “L8” flashes to signal the maximum force.

There is no relation between the force level indicated by the LEDs during the movement (which is an absolute value) and the level indicated by the LEDs during the force (which is a relative value) programming phase. See “L6” in “Table 21”.

8.3 LEVEL 2 PROGRAMMING (ADJUSTABLE PARAMETERS)

All the Level 2 parameters are factory-set as highlighted in “**GREY**” in “**Table 21**” and can be modified at any time. The parameters can be set to a scale of 1 to 8. To check the value corresponding to each LED, refer to “**Table 21**”.

ATTENZIONE: If the configuration of a parameter (Level 2) is not recognised with respect to the configurations present, the control unit will switch on the two LEDs **L1** and **L8** simultaneously and intermittently to signal that the present value is out of range. If necessary, the values can be forced by pressing the [**Open ▲**] or [**Close ▼**] button.

8.3.1 LEVEL 2 PROGRAMMING PROCEDURE

To perform Level 2 programming:

1. press and hold the [**Stop/Set**] button until LED “**L1**” starts flashing
2. release the [**Stop/Set**] button
3. press the [**Open ▲**] or [**Close ▼**] button to move the flashing LED to the “**entry LED**” associated with the parameter to be modified
4. press and hold the [**Stop/Set**] button. With the [**Stop/Set**] button pressed down:
 - wait roughly 3 seconds, until the LED representing the current level of the parameter to be modified lights up
 - press the [**Open ▲**] or [**Close ▼**] button to shift the LED associated with the parameter's value
5. release the [**Stop/Set**] button to return to the first level
6. wait 20 seconds (maximum time), without pressing any button, to exit the programming mode.



To set multiple parameters during the procedure's execution, repeat the operations from point 2 to point 5 during the phase itself.

Table 21

LEVEL 2 FUNCTIONS (ADJUSTABLE PARAMETERS)				
Entry LED	Parameter	LED (level)	Set value	Description
L1	Pause Time	L1	5 seconds	Adjusts the pause time, in other words, the time before automatic re-closure. It is only effective if the “Automatic Closing” function is enabled.
		L2	15 seconds	
		L3	30 seconds	
		L4	45 seconds	
		L5	60 seconds	
		L6	80 seconds	
		L7	120 seconds	
		L8	180 seconds	
L2	Step-by-Step function	L1	Open - Stop - Close - Stop	Controls the sequence of controls associated with the Sbs input or the 1st radio command. NOTE: by setting the level on L4, L5, L7, L8 , also the behaviour of the “Open” and “Close” commands is modified.
		L2	Open - Stop - Close - Open	
		L3	Open - Close - Open - Close	
		L4	Condominium	
		L5	Condominium 2 (more than 2 sec triggers “Stop”)	
		L6	Step-by-Step 2 (more than 2 sec triggers “Partial Open”)	
		L7	Hold-to-run	
		L8	Opening in “semi-automatic” mode, closing in “hold-to-run” mode	
L3	Motor speed	L1	Speed 1 (30% - slow)	Adjusts the motor speed during normal manoeuvres.
		L2	Speed 2 (44%)	
		L3	Speed 3 (58%)	
		L4	Speed 4 (72%)	
		L5	Speed 5 (86%)	
		L6	Speed 6 (100% - fast)	
		L7	Open V4, close V2	
		L8	Open V6, close V4	

LEVEL 2 FUNCTIONS (ADJUSTABLE PARAMETERS)				
Entry LED	Parameter	LED (level)	Set value	Description
L4	FLASH output (Out1)	L1	Door Open Indicator	Selects the device connected to the FLASH output.
		L2	Enabled if door closed	
		L3	Enabled if door open	
		L4	Warning light	
		L5	Electric latch	
		L6	Electric lock	
		L7	Suction cup	
		L8	Maintenance	
L5	OGI output (Out2)	L1	OGI	Selects the device connected to the OGI output.
		L2	Phototest	
		L3	Door status	
		L4	Courtesy light	
		L5	CH 1 radio	
		L6	CH 2 radio	
		L7	CH 3 radio	
		L8	CH 4 radio	
L6	Motor force (%)	L1	Opening 60, closing 30	Adjusts the motor force control system to adapt it to the weight of the door during the manoeuvres.
		L2	Opening 60, closing 40	
		L3	Opening 70, closing 40	
		L4	Opening 70, closing 50	
		L5	Opening 80, closing 50	
		L6	Opening 80, closing 60	
		L7	Opening 90, closing 70	
		L8	Opening 90, closing 80	
L7	Sensitivity	L1	Sensitivity deactivated	Adjusts the level of sensitivity in detecting obstacles.
		L2	Opening 10, closing 20	
		L3	Opening 20, closing 30	
		L4	Opening 30, closing 40	
		L5	Opening 40, closing 50	
		L6	Opening 50, closing 60	
		L7	Opening 60, closing 70	
		L8	Opening 70, closing 80	
L8	Discharge	L1	No discharge	This function allows for releasing the mechanical tension that accumulates in the components after every manoeuvre. When the closing position is reached, the motor will perform a brief inversion to release the belt or chain tension.
		L2	min.	
		L3	...	
		L4	...	
		L5	...	
		L6	...	
		L7	...	
		L8	max.	

- All the parameters can be adjusted as required without any contraindications; only the “Motor force” adjustments could require special attention:
- high force values should not be used to compensate for points of abnormal friction on the leaf. Excessive force can jeopardise the operation of the safety system or damage the leaf
 - if the “Motor Force” control is used to aid the impact force reduction system, measure the force again after each adjustment in accordance with the EN 12445 standard
 - wear and atmospheric conditions influence the door’s movement, so the force settings should be checked periodically.

8.4 SPECIAL FUNCTIONS

8.4.1 “ALWAYS OPEN” FUNCTION

The “Always open” function is a control unit feature that enables the user to always command an opening manoeuvre when the “Step-by-Step” command lasts longer than 2 seconds; this is useful, for example, for connecting a timer contact to the SbS terminal in order to keep the automation open for a certain time frame.

This feature is valid regardless of how the “SbS” input is programmed, unless it is programmed to perform the “Condominium 2” function. Refer to the “Step-by-Step function” under the “Level 2 programming (adjustable parameters)” paragraph.

8.4.2 “MOVE ANYWAY” FUNCTION

This function can be used to operate the automation even one or more safety devices fail to work properly or are out of order. The automation can be controlled in “hold-to-run” mode by proceeding as follows:

1. send a command to move the automation, using a transmitter or key selector, etc. If everything works properly, the boom will move normally, otherwise proceed with point 2
2. within 3 seconds, press the control again and hold it down
3. after roughly 2 seconds, the automation will complete the requested manoeuvre in “hold-to-run” mode, in other words, it will continue to move so long as the control is held down.



When the safety devices fail to work, the flashing indicator will flash a few times to signal the type of problem. To verify the type of anomaly, consult the “Signalling through warning light” chapter (page 34).

8.4.3 “MAINTENANCE NOTICE” FUNCTION

This function warns the user when the automation requires a maintenance check. The number of manoeuvres after which the signal is given can be configured through the MyNicePro app or through all compatible Nice interfaces.

With every manoeuvre, the automation switches on the green or red light simultaneously with the white courtesy light to signal the maintenance status according to the behaviour described in the table below:

Table 22

MAINTENANCE NOTICE		
LED light	Live	Description
Green	steady lit at the start of each manoeuvre	Normal operation
Red	steady lit at the start of each manoeuvre	We recommend subjecting the entire automation to maintenance by qualified personnel

8.4.4 “MAINTENANCE RESET” FUNCTION

Following a significant maintenance intervention (replacement of cables, balancing springs, guide, etc.), it is possible to reset the maintenance counter through a compatible interface and the MyNicePro app. In this case, the system forces an “automatic force search” procedure (see the paragraph “Automatic force search” (page 17), to adapt more rapidly to the new mechanical configuration.

8.4.5 “REALIGNMENT” FUNCTION

If the power supply fails during the maneuver, a “position search” may be required once it is restored to confirm the closing position. In this case, the courtesy light flashes quickly to signal the realignment request. When a command is received, the motor performs a slow closing maneuver to the ground and a series of adjustments to confirm the height.

8.5 WI-FI CONNECTION

SPIDER motors are configured for Wi-Fi connectivity for enabling:

- remote control of the automation (through the MyNice app)
- the installer: configuration of the automation (through the MyNice Pro app)

In particular, Wi-Fi connectivity is available with three modes:

- Wi-Fi module integrated in the control unit (if included in the purchased model)
- The BiDi-Wifi interface supplied on request as an accessory
- The Proview interface (only for the MyNice Pro app) supplied on request as an accessory



The application of the BiDi-Wi-Fi interface to the busT4 port present on the automation must be regarded as alternative to the BiDi-ZWave interface.

To use the automation’s Wi-Fi connectivity in the available modes, it is necessary to:

- Install, depending on the desired use, the MyNice app or the MyNice Pro app (reserved for the installer) available on Google Play Store and Apple App Store
- Power the automation and verify that the available Wi-Fi device switches on normally
- Launch the installed app and configure the Wi-Fi device from the “Wi-Fi interface or Accessories” menu

For further details relative to the functions linked to the MyNice Pro and MyNice apps, consult the website www.niceforyou.com.

8.5.1 INTEGRATED WI-FI MODULE (DEPENDENT ON THE VERSION)

The module integrated in the control unit has 2 buttons (P1 and P2) and 2 LED (W1 and W2): these behave differently on the basis of the various operating phases.

Indicated below are the buttons and LEDs with which the user can interact:

- W1 = Power/Sys (power LED and integrated Wi-Fi module status LED)
- W2 = Wi-Fi / BT (Wi-Fi communication status LED)
- P1 = 10 s pressing = resetting of factory settings
- P2 = not used

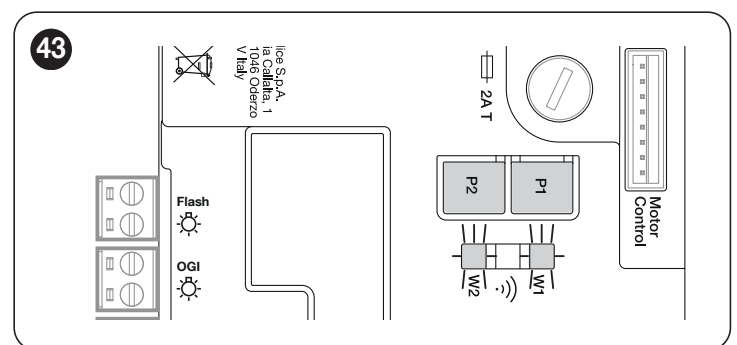

WARNING = To install on and associate a device with the control unit, follow the guided procedure present in the MyNice or MyNice Pro app. For further information, consult the website www.niceforyou.com

WI-FI MODULE LED STATUS			
WiFi /BT (W2)	Power/Sys (W1)	LEDs W1 and W2 status	Description
Lit green	Lit green	Stable	The integrated module is in its normal operating status and a smartphone is connected.
Lit green	Green, 8 quick flashes	Temporary (a few seconds)	The module has undergone an “Identify” action by the user.
Flashing green	Lit green	Stable	The module is awaiting to receive the Wi-Fi network configuration from the user. Use the app to configure the module.
Lit orange	Lit green	Stable	The module is in its normal operating status and no smartphone is connected.
Flashing orange	Steady green	Temporary (a few seconds)	The module is configuring the Wi-Fi connection. If permanent, it means that a problem occurred during the Wi-Fi configuration.
OFF	Steady green	Stable	The module cannot be configured because 30 minutes have passed from the switching on (only with a module that has not yet been configured). To configure the module, disconnect the power supply to the control unit and then restore it.
OFF	Flashing orange	Temporary (roughly 1 minute)	The module is updating. Wait for the operation to be completed. If the operation is not completed correctly, the module automatically restarts after 5 minutes.
Flashing red	OFF	Transitory	The module has detected the pressing of the reset button when the control unit was switched on.
Steady red	Lit green	Stable	The module cannot connect to the domestic Wi-Fi network or is unable to connect to the Nice cloud.

8.5.2 BIDI-WI-FI INTERFACE

To connect the BiDi-Wi-Fi interface:

1. Disconnect the power supply to the control unit by removing the fuse F1 and, if necessary, the emergency power supply

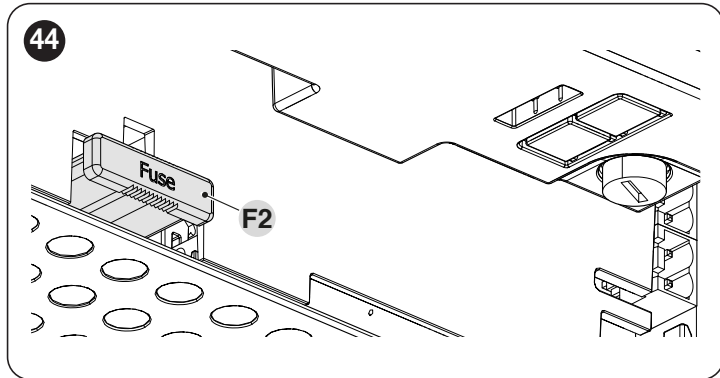

2. Verify that all the control unit LEDs are switched off before proceeding

Insert the BiDi-Wi-Fi interface in the BUS T4 connector of the control unit

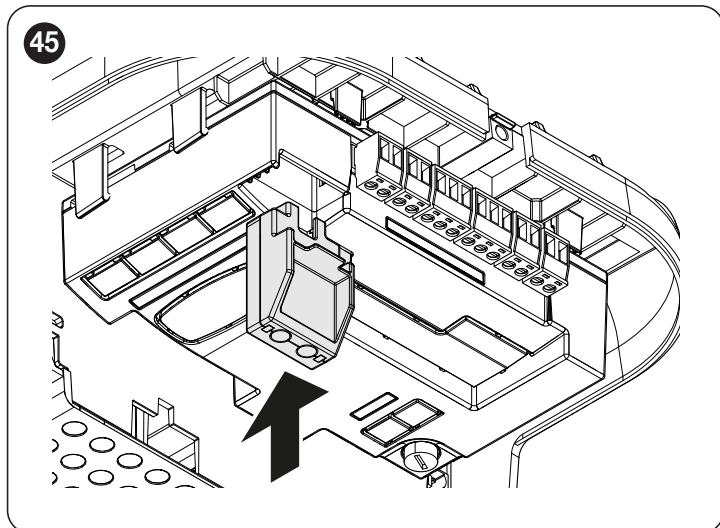

Warning! If it is not correctly inserted, the BiDi-Wi-Fi interface could get damaged or permanently damage the control unit.

3.

Insert fuse F2 to switch the control unit on again

4.

Wait for the **Date** LED to start flashing

5.

Configure the interface through the app

6.

Wait until the **Date** LED switches on and the green light stays steady lit. At this point the configuration will have been completed.



For further details relative to the functions linked to the BiDi-Wi-Fi interface, consult the website www.niceforyou.com.

8.6 CONNECTING THE PRO-VIEW

The control unit has a BusT4 connector to which it is possible to connect, through the IBT4N interface, the “Pro-View” interface, which allows for fully and rapidly managing the installation, maintenance and diagnosis of the entire automation through a Wi-Fi connection and the MyNice Pro app. After correctly powering the Pro-View accessory, a Wi-Fi network will be created automatically to which the user must connect. When the Pro-View accessory is paired, the Power status LED (A) and the Wi-Fi status LED (B) are lit green.

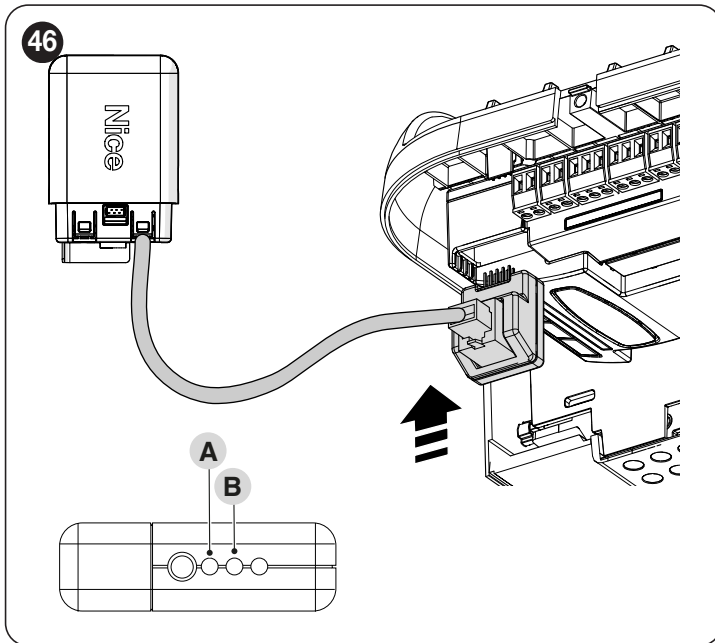

 For further details relative to the functions linked to the Pro-View interface and the MyNice Pro app, consult the website www.niceforyou.com.

8.7 Z-WAVE™

The SPIDER motors are compatible with the Z-Wave™ protocol to enable the user to manage all the automation's functions in an extremely simple way, through the Z-Wave™ gateway app installed at home. In particular, the Z-Wave™ connectivity is available with the BiDi-ZWave interface which can be used to control the movement and status of the automations.

 The application of the BiDi-ZWave interface to the busT4 port present on the automation must be regarded as alternative to the BiDi-Wi-Fi interface.

 For further details relative to the functions linked to the BiDi-ZWave interface, consult the website www.niceforyou.com.

8.8 MEMORY DELETION

 The procedure described below restores the control unit's default settings. All the custom settings will be lost.

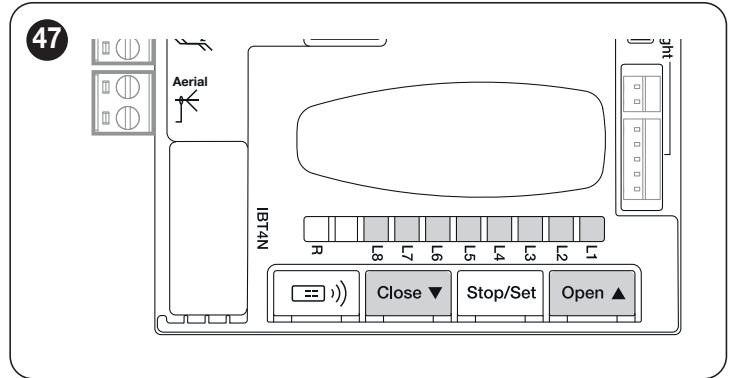

To delete the control unit's memory and restore all the default settings, proceed as described below:

1. press and hold the [Open ▲] and [Close ▼] buttons until the programming LEDs “L1-L8” light up (after roughly 3 seconds)
2. release the buttons
3. if the operation was successful, the programming LEDs “L1” to “L8” flash quickly for 3 seconds.

 With this procedure it is possible to also delete any errors left in the memory.

 This procedure does not cancel the radio codes memorised in the radio receiver (integrated and/or external)

9.1 TROUBLESHOOTING

The table below contains useful instructions to resolve any malfunctions or errors that may occur during installation or in case of a fault.

Table 24

TROUBLESHOOTING	
Problems	Recommended checks
The radio transmitter does not control the automation and the LED on the transmitter fails to light up	Check whether the transmitter batteries are exhausted and replace them if necessary.
The radio transmitter does not control the automation but the LED on the transmitter lights up	Check whether the transmitter has been memorised correctly in the radio receiver.
No manoeuvre is commanded and the "OK" LED fails to flash	Check that the gearmotor is being powered with the mains voltage Check whether fuses F1 and F2 are blown; if they are, identify the cause of the failure then replace the fuses with others having the same current rating and characteristics.
No manoeuvre starts and the warning light is off	Check that the command is actually received. If the command reaches the SbS input, the "OK" LED must light up; if instead the radio transmitter is used, the "OK" LED must emit two quick flashes.
No manoeuvre starts and the warning light flashes a few times	Count the number of flashes and check the corresponding value in " Signalling through warning light ".
The manoeuvre starts but is immediately followed by a reverse run	The selected force could be too low for this type of automation. Check whether there are any obstacles and increase the force if necessary. Check whether a safety device connected to the Stop input has tripped.
The manoeuvre is completed correctly but the warning light does not work	Make sure that there is voltage on the warning light's FLASH terminal during the manoeuvre (being intermittent, the voltage value is not significant: roughly 10–30 V \approx); if there is voltage, the problem is due to the lamp, which must be replaced with one having the same characteristics; if there is no voltage, there may have been an overload on the FLASH output. Check that the cable has not short-circuited.

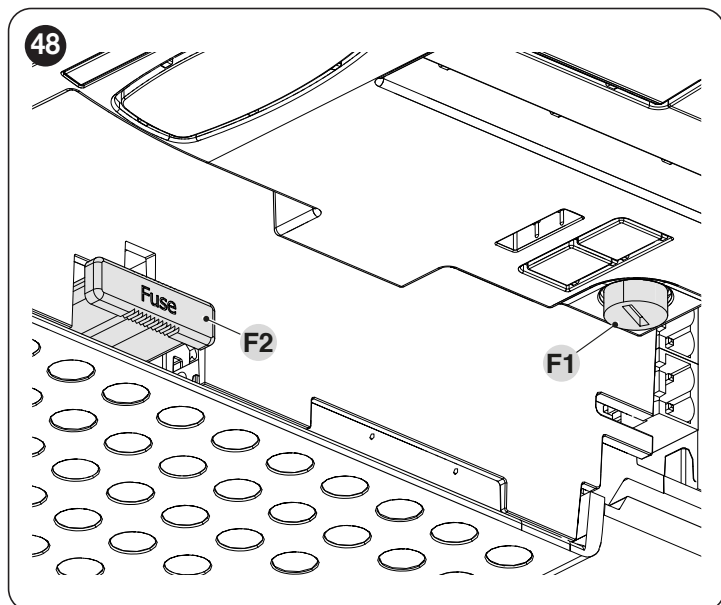

Table 25

CHARACTERISTICS OF FUSES F1 AND F2	
F1	Control unit fuse = 2 A delayed
F2	Mains power supply fuse = 1.6 A delayed

The product is fitted with integrated white-LED lights and is designed to illuminate the room from the start to the end of the manoeuvre and after the manoeuvre itself for the set time. Moreover, the motor head is fitted with green and red LEDs, the latter for signalling the presence of more frequent anomalies. "Table 27" shows the potential switch-on statuses.

Table 27

BEHAVIOUR OF LED LIGHTS INTEGRATED IN THE MOTOR HEAD	
White light	
Lit	The automation is moving or has just stopped. It will switch off autonomously after the programmed time.
Lit for 3 seconds	Execution of an Automation Lock Command completed.
Off	Normal operation / motor stopped pending commands.
Slow flashing	"Automatic Force Search" function in progress (refer to the " Automatic force search " chapter on page 17).
Fast flashing	"realignment" function to be performed (see chapter " Realignment " function" on page 30).
Green light	
Lit	The light remains active throughout the manoeuvre.
Off	The light remains off if the automation does not move.
Red light	
Lit	The light remains on for the entire duration of the manoeuvre if the set number of manoeuvres for maintenance has been exceeded.
Off	Normal operation.
Warning light	The control unit has detected an anomaly: Refer to " Table 26 "
Alternating flashing	The firmware update procedure of one or more product cards is in progress or pending.

Table 28

TERMINAL LEDs ON THE CONTROL UNIT		
Status	Meaning	Possible solution
BlueBus LED		
OFF	Anomaly	Check for the presence of power; check that the fuses are not blown; if necessary, identify the cause of the fault then replace them with fuses having the same specifications.
On	Serious anomaly	There is a serious anomaly; try switching off the control unit for a few seconds; if the condition persists, it means that there is a fault and the electronic circuit board must be replaced.
2 green flashes per second	Everything normal	Normal control unit operation.
2 quick green flashes	The status of the inputs has changed	This is normal when there is a change in one of the inputs: SBS, STOP, OPEN, CLOSE, the photocells intervene or the radio transmitter is used.
A series of flashes separated by a 1-second pause	Various	Refer to that shown in " Signalling through warning light ".
A series of quick and extended red flashes	Short circuit on the BlueBUS terminal clamp	Disconnect the terminal and verify the cause of the short-circuit on the BlueBUS connections. If the short-circuit is resolved, the LED will start flashing normally after about ten seconds.
Orange flash	Backup batteries charging with Standby Mode running	Normal system operation. Occurs only with updated backup batteries for Standby products.
STOP LED		
OFF	Intervention of the STOP input	Check the devices connected to the STOP input.
On	STOP did not intervene	STOP input active.
SbS LED		
OFF	Everything normal	SbS input not active.
On	Intervention of the SbS input	This is normal if the device connected to the SbS input is actually active.
Led PHOTO		
OFF	Intervention of the PHOTO input	PHOTO input intervened.
On	Everything normal	This is normal if the safety device did not intervene.





















LEDS ON THE CONTROL UNIT BUTTONS	
LED 1	Description
OFF	During normal operation, this indicates that “Automatic Closing” is disabled.
On	During normal operation, this indicates that “Automatic Closing” is active.
Flashes	Function programming in progress. If it flashes together with “L2”, it means that the device learning phase must be carried out (refer to the “ Device learning ” paragraph). If it flashes together with “L8”, it means that the value of the function being programmed at level 2 is out of range (see the paragraph “ Level 2 programming (adjustable parameters) ”).
LED 2	Description
OFF	During normal operation, it signals that the “Close after photo” mode is not active.
On	During normal operation, it signals that the “Close after photo” mode is active.
Flashes	Function programming in progress. If it flashes together with “L1”, it means that the device learning phase must be carried out (see the “ Device learning ” paragraph)
LED 3	Description
OFF	During normal operation, this indicates that “Always Close” is not active.
On	During normal operation, it signals that “Always close” is active.
Flashes	Function programming in progress. If it flashes together with L4, it means that the door opening and closing positions must be learned (refer to the “ Manual programming of the door opening and closing positions ” paragraph).
LED 4	Description
OFF	During normal operation, it signals that the “Stand-by” mode is not active.
On	During normal operation, it signals that the “Stand-by” mode is active.
Flashes	Function programming in progress. If it flashes together with L3, it means that the door opening and closing positions must be learned (refer to the “ Manual programming of the door opening and closing positions ” paragraph).
LED 5	Description
OFF	During normal operation, it indicates that the “Anti-tamper” mode is not active.
On	During normal operation, it indicates that the “Anti-tamper” mode is active.
Flashes	Function programming in progress.
LED 6	Description
OFF	During normal operation, it signals that the “Pre-flashing” mode is not active.
On	During normal operation, it signals that the “Pre-flashing” mode is active.
Flashes	Function programming in progress.
LED 7	Description
OFF	During normal operation, it indicates that “Internal radio inhibition” is not enabled.
On	During normal operation, it indicates that “Internal radio inhibition” is enabled.
Flashes	Function programming in progress.
LED 8	Description
OFF	During normal operation, it indicates that the “Heavy Door” mode is active.
On	During normal operation, it indicates that the “Light Door” mode is active.
Flashes	Function programming in progress. If it flashes together with “L8”, it means that the value of the function being programmed at level 2 is out of range (see the paragraph “ Level 2 programming (adjustable parameters) ”).

During each manoeuvre, the LEDs light up proportionally to signal the force applied by the motor to move the automation. Below is the sequence with which the LEDs light up in relation to the force:

- from L1 to L3 in case of low force
- from L1 to L5 in case of medium force
- from L1 to L8 in case of high force.



WARNING: with the motor stationary, the sequential lighting up of LEDs L1 → L2 → L3 → L4 → L5 → L6 → L7 → L8 indicates that the product's FW is being updated, so it is necessary to wait for the updating process to end before the automation can be used again! We suggest not disconnecting the motor from the power supply.

SIGNAL OF LED R ON THE CONTROL UNIT		
Long flashes > GREEN at start-up		
Current encoding system: "O-Code"	2	
No remote control memorised	5	
Long flashes > GREEN during operation		
Indicates that the code received is not stored in the memory	1	
Saving of the code in memory	3	
Memory deleted	5	
During programming, indicates that the code is not authorised for memorisation	6	
During programming, indicates that the memory is full	8	
Short flashes > GREEN		
"Certificate" not valid for memorisation	1	
During programming, it indicates that the code cannot be memorised because it transmits the "certificate"	2	
Output in "Mode 2" not managed on the control unit	4	
During the deletion procedure, indicates that the code has been deleted	5	
"Certificate" with lower priority than the admissible level	5	
Code synchronisation failure	6	
Long flashes > RED		
Non-original code block	1	
Code with lower priority than the authorised level	2	
Short flashes > RED		
"In vicinity" programming block	1	
"Certificate" memorisation block	1	
Memory block (PIN entry)	2	
Long flashes > ORANGE		
(At start-up, after a few green flashes). Indicates the presence of Bidirectional transmitters	1	
Short flashes > ORANGE		
Indicates activation of block programming (at start-up)	2	

10 FURTHER DETAILS (Accessories)

10.1 ADDING OR REMOVING DEVICES

Once the automation has been assembled, it is possible to add or remove devices at any time. In particular, various types of devices can be connected to the “BlueBUS” and “STOP” inputs, as described in the following paragraphs.



After having added or removed devices, these must be learned as described in the “*Learning of other devices*” paragraph.



Warning! To add or remove an expansion board, it is first necessary to switch off the power supply.

10.1.1 BLUEBUS

BlueBUS is a technology that allows the connections of compatible devices to be made with only two conductors over which both power supply and communication signals pass. All devices are connected in parallel on the same 2 BlueBUS conductors and without the need to respect any polarity; each device is recognised individually as it is assigned a unique address during installation.

The following devices can be connected to the BlueBUS: photocells, safety devices, control buttons, signalling lights, etc. The control unit recognises all the connected devices individually through an appropriate learning phase, and can detect all possible anomalies with absolute precision. For this reason, whenever a device is connected to or removed from BlueBUS, the learning phase must be carried out on the control unit, as described in the “*Learning of other devices*” paragraph.

10.1.2 STOP INPUT

STOP is the input that causes the immediate interruption of the manoeuvre, followed by a brief inversion. Devices with normally open (“NO”) and normally closed (“NC”) contacts, optical devices (“Opto Sensors”) or devices with 8.2 kΩ fixed resistor output (such as sensitive edges) can be connected to this input.

During the device learning phase, the control unit recognises the type of device connected to the STOP input and later, during normal use of the automation, the control unit commands a STOP when it senses a change with respect to the acquired situation.

Multiple devices, even of different types, can be connected to the STOP input if suitable arrangements are made:

- Any number of NO devices can be connected to each other in parallel.
- Any number of NC devices can be connected to each other in series.
- Two devices with 8.2 kΩ fixed resistor output can be connected in parallel; if there are more than 2 devices then they must all be connected in cascade, with a single 8.2 kΩ terminating resistor.
- It is possible to combine two NO and NC contacts by placing them in parallel, while also mounting a 8.2 kΩ resistor in series with the NC contact (this also allows for combining 3 devices: NA, NC and 8.2 kΩ).
- To connect an optical device, refer to the diagram shown in “*Figure 50*”. The maximum current supplied on the 12 VDC line is 15 mA.

50

OPTICAL SENSOR (max 15mA)

STOP (-)

SIGNAL

12 V (+)

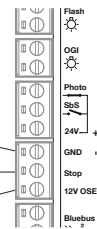

10.1.3I/O EXPANSION BOARD (OPTIONAL ACCESSORY)

The control unit is configured for housing various versions of I/O expansion boards which make available additional inputs and outputs. Each additional input/output can be personalised as if it were a physical input/output of the control unit.

Whenever an expansion board is inserted or removed, the “*device acquisition*” procedure must be carried out: if this is not done, the motor’s movement will remain limited to the “hold-to-run” function.



The addition or removal of expansion boards must always be carried out without power supply (by removing both fuse F2 and, if present, the battery pack).

To add the expansion board:

1. disconnect the control unit from the power supply
2. remove the pre-detachment element (A)
3. fit the expansion (B) into the appropriate slot on the control unit circuit board.
4. power the control unit
5. repeat the learning procedure for the devices as described in the paragraph “*Learning of other devices*”.

51

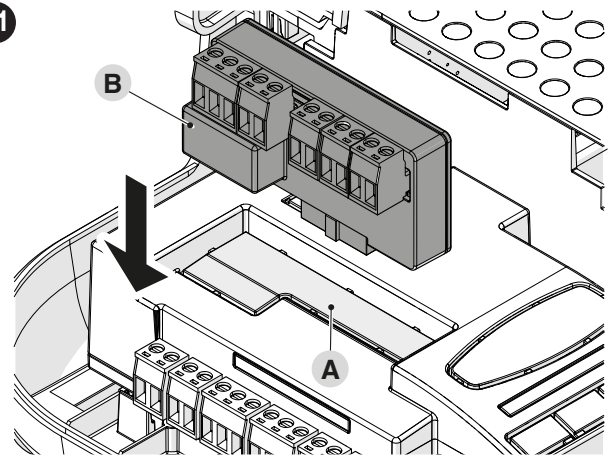

Warning! On some models the expansion board is supplied as a standard feature



Warning! Verify the electrical consumption of the control unit and of the expansion board. Do not exceed the maximum allowed power.

The specific manual of the expansion board is available on-line. Use your smartphone to frame the QR Code of the board.

52

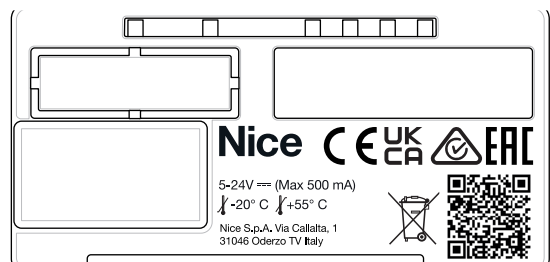

EXPANSION BOARD			
Product	Description	Input characteristics	Output characteristics
MLAE44	4 Input 4 Output	IN 3 = dry contact (COM - IN3) IN 4 = dry contact (COM - IN4) IN 5 = dry contact (COM - IN5) IN 6 = dry contact (COM - IN6)	OUT3 = Open Drain (max 10W = 24V - 0.4A) OUT4 = Open Drain (max 10W = 24V - 0.4A) OUT5 = Open Drain (max 10W = 24V - 0.4A) OUT6 = Open Drain (max 10W = 24V - 0.4A)
MLAE22	2 Input 2 Output	IN 3 = dry contact (COM - IN3) IN 4 = dry contact (COM - IN4)	OUT3 = Open Drain (max 10W = 24V - 0.4A) OUT4 = dry contact with relay in exchange (230VAc - 5A)
MLAE21	2 Input 1 Output	IN 3 = dry contact (COM - IN3) IN 4 = dry contact (COM - IN4)	OUT3 = Open Drain (max 10W = 24V - 0.4A)

10.1.4 LEARNING OF OTHER DEVICES

Normally the learning of devices connected to “BlueBus” and the “STOP” input takes place during the installation stage; however, if new devices are added or old ones removed, the learning process can be redone.

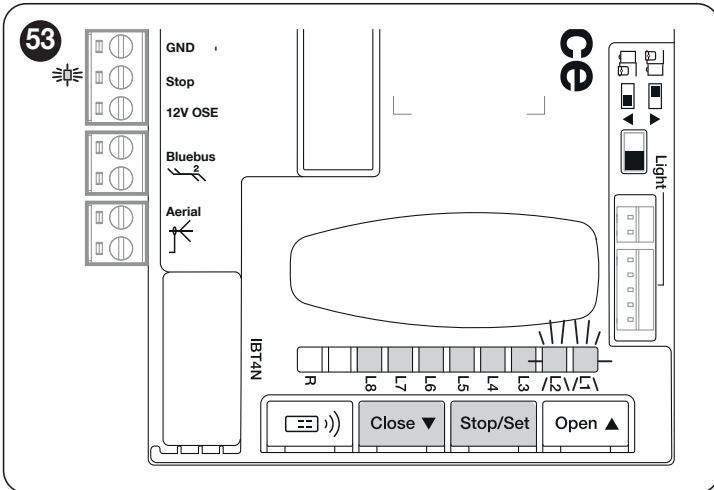

To do this:

1. simultaneously press and hold the [Open ▲] and [Stop/Set] buttons
2. release the buttons when LEDs “L1” and “L2” start flashing rapidly (after roughly 3 seconds)
3. wait a few seconds until the control unit has completed the device learning phase
4. at the end of this phase, the “Stop” LED must be lit, LEDs “L1” and “L2” must switch off, while LEDs “L1...L8” will switch on depending on the status of the ON-OFF functions they represent.



After having added or removed devices, the automation test must be carried out again as specified in the “Testing” paragraph.

10.1.5 CONNECTING AN SM-TYPE RADIO RECEIVER (OPTIONAL ACCESSORY)

The control unit has a slot for mounting radio receivers with SM connector (optional accessories) belonging to the OXI, OXIBD, etc. families, which can be used to remotely control the control unit through radio transmitters. Before proceeding with the installation of a receiver, inhibit the operation of the internal radio (refer to the paragraph “Level 1 programming (ON-OFF)”) and disconnect the power supply to the control unit.

To install a receiver: “Figure 54”.

1. remove the pre-detachment element (A);
2. fit the receiver (B) into the appropriate slot on the control unit circuit board;
3. restart the control unit.

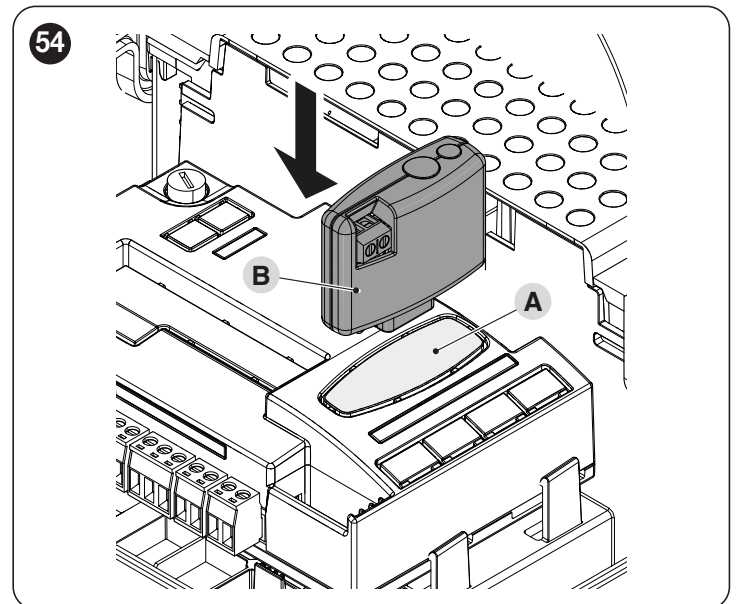

For the commands available and the memorisation modes, refer to the modes relevant to the programming of the integrated radio receiver. (refer to the “RADIO PROGRAMMING” chapter).

10.1.6 RELAY PHOTOCELLS WITH PHOTOTEST FUNCTION

The control unit features a PHOTOTEST function which increases the reliability of the safety devices, enabling it to be classified in Category 2 in accordance with the EN 13849-1 standard regarding the combination of the control unit and safety photocells.

Warning! To activate the PHOTOTEST function, it is necessary to modify the programming of the OGI output (refer to the “**Level 2 programming (adjustable parameters)**” chapter on page 28).

Whenever a manoeuvre is started, all safety devices involved are checked and only if everything operates correctly will the manoeuvre start. Should the test fail (photocell blinded by the sun, cables short-circuited, etc.), the fault is identified and the manoeuvre is disabled.

Connect the photocells as shown in “**Figure 55**”.

Deactivate Standby Mode (see chapter “**Level 1 programming (ON-OFF)**”).

Wiring diagram with relay photocells with PHOTOTEST

 All images of the accessories are included purely for illustration purposes.

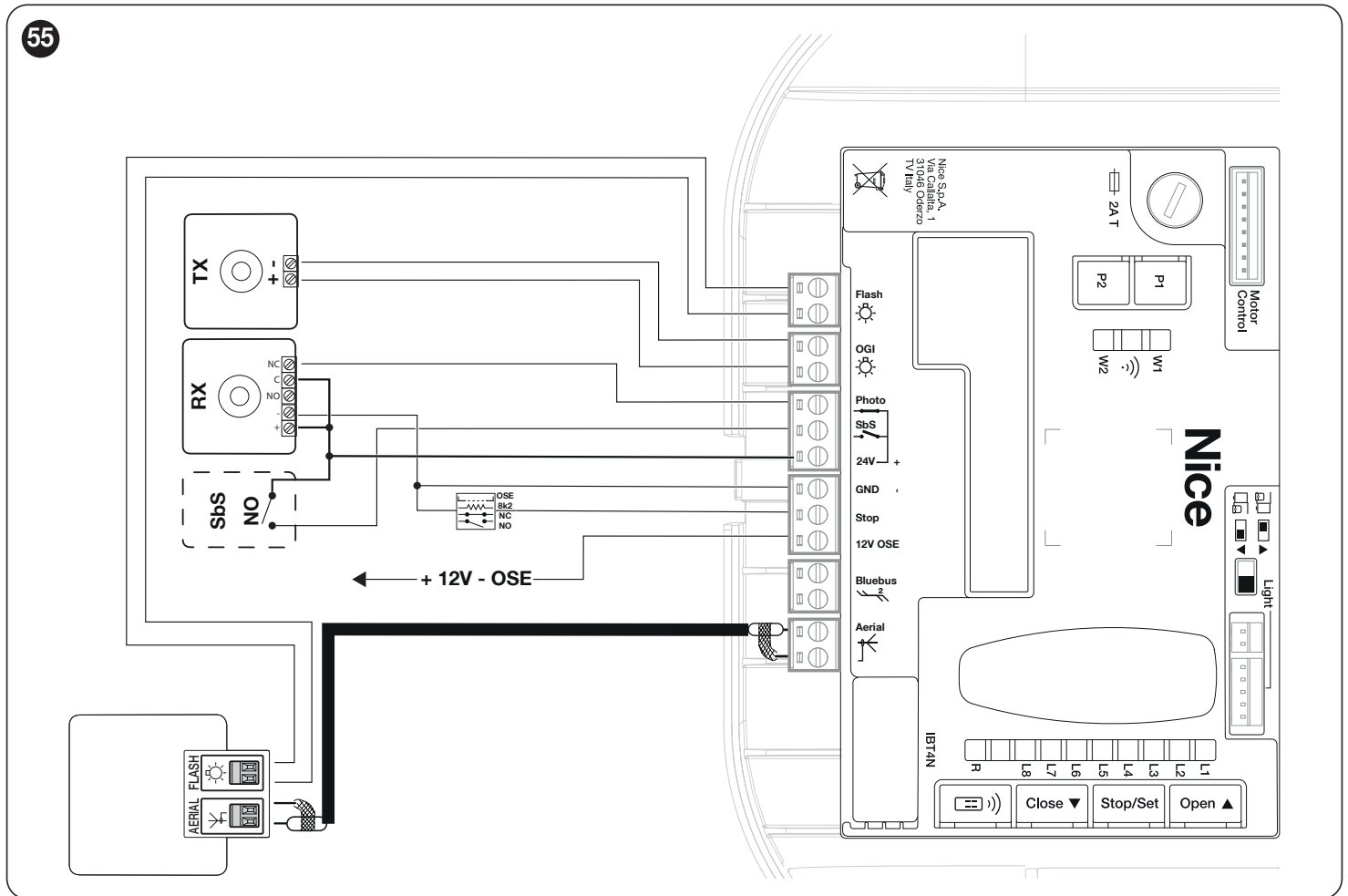

 If 2 pairs of photocells are used that interfere with one another, it is necessary to activate the “synchronisation” as described in the photocell instruction manual.

 In any devices of the automation are replaced, added or removed, it is necessary to run the learning procedure (see the “**Manual programming of the door opening and closing positions**” chapter on page 16).

10.1.7 RELAY PHOTOCELLS WITHOUT PHOTOTEST FUNCTION

The control unit has the dedicated PHOTO input to which it is possible to connect the NC contact of the relay photocells. Unlike the configuration with "PHOTOTEST", after a command is given the manoeuvre is carried out without checking the validity of the signal coming from the photocells, without nonetheless altering the external photocells' reactivity to the status change.

Warning! To remove the PHOTOTEST function, it is necessary to modify the programming of the OGI output (refer to the "Level 2 programming (adjustable parameters)" chapter on page 28).

Connect the photocells as shown in "Figure 56".
Deactivate Standby Mode (see chapter "Level 1 programming (ON-OFF)").

Wiring diagram with relay photocells without PHOTOTEST

All images of the accessories are included purely for illustration purposes.

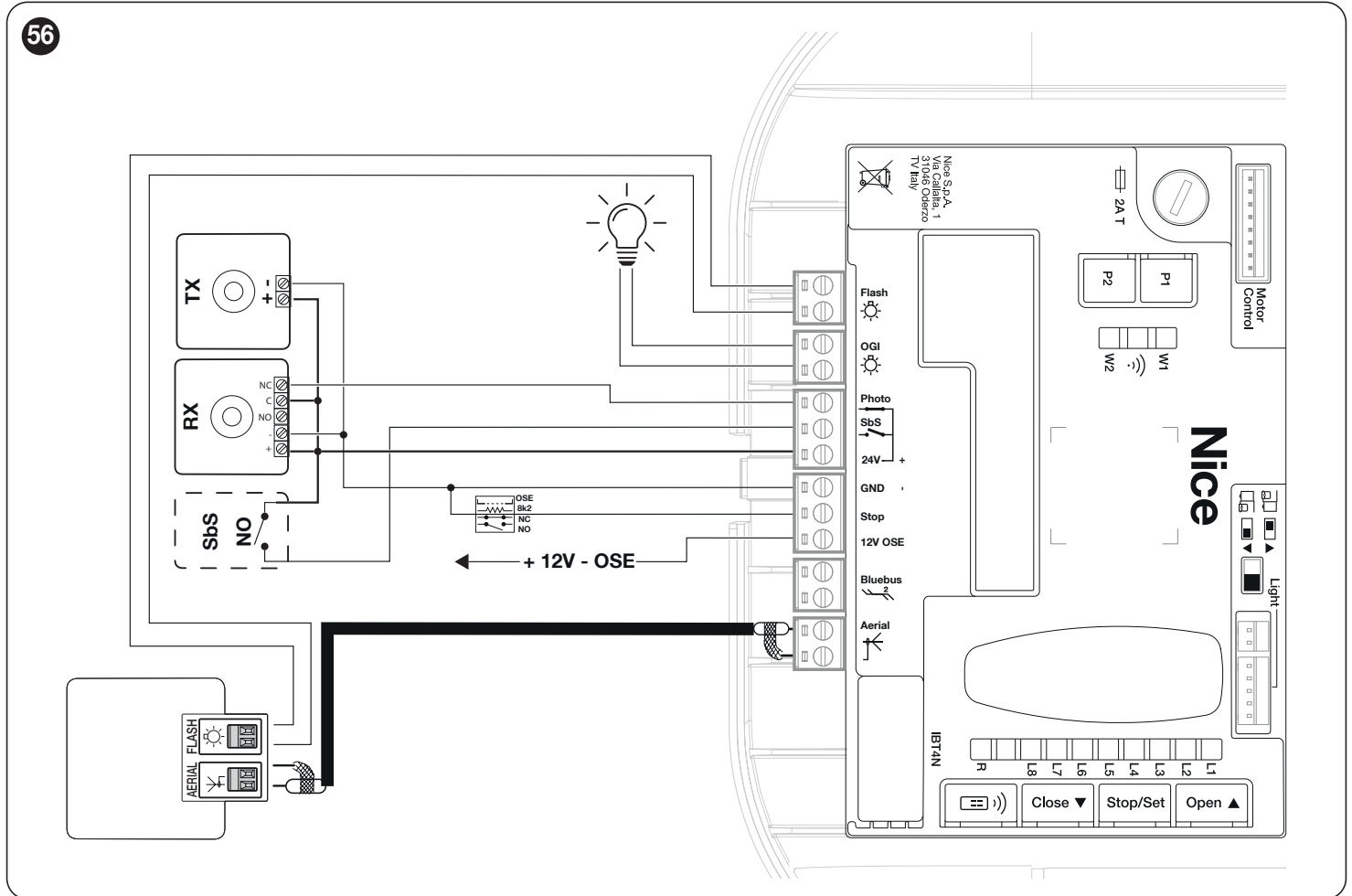

10.1.8 ELECTRIC LOCK

The OGI output is by default enabled for the OGI (Open Gate Indicator) function, but can be programmed for controlling an electric lock (refer to the “**Level 2 programming (adjustable parameters)**” paragraph on page 28).

At the start of the opening movement, the output is activated for 2 seconds, while during the closing manoeuvre it is not activated, therefore the electric lock must reset mechanically.

The output cannot control the electric lock directly, but only loads of 24 V \approx 10W.

The output must be interfaced with a relay, as shown in the figure.

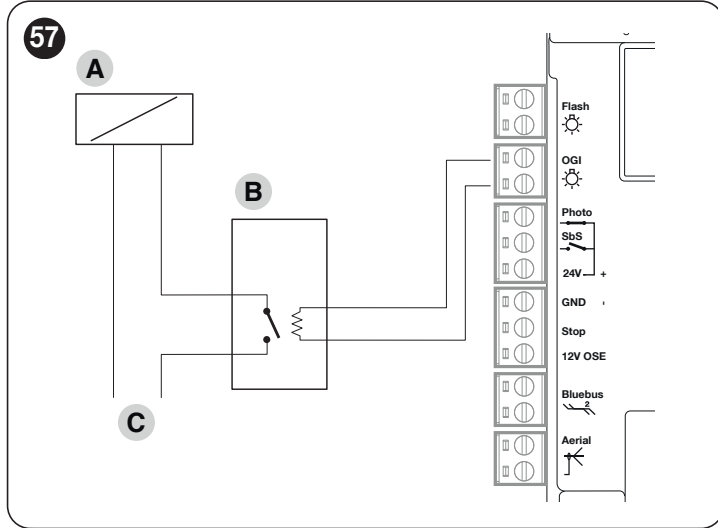

- A Electric lock
- B 24 V \approx support relay
- C Electric lock power supply

10.2 CONNECTING AND INSTALLING THE EMERGENCY POWER SUPPLY



The electrical connection of the battery to the control unit must be made only after completing all the installation and programming stages, as the battery is an emergency power supply.

This product can be equipped with an emergency power supply system that ensures operation even in the absence of mains power. The emergency power supply is through batteries that must be kept in the charged state. The battery charging function is one of the main functions of this product; the Standby Mode will be activated only when the battery charging function is completed.

Check the instructions of the emergency power system for the maximum time required for the batteries to be fully charged.



WARNING

Use the pre-addressed backup battery pack for operation with Standby (PSS124) power packs. If the PS124 battery pack is used instead, it is necessary to disable the Standby Mode for proper operation.

To install and connect the battery:

1. loosen the screw (A)
2. pull the cover (B) slightly outwards and turn it downwards (“**Figure 58**”)

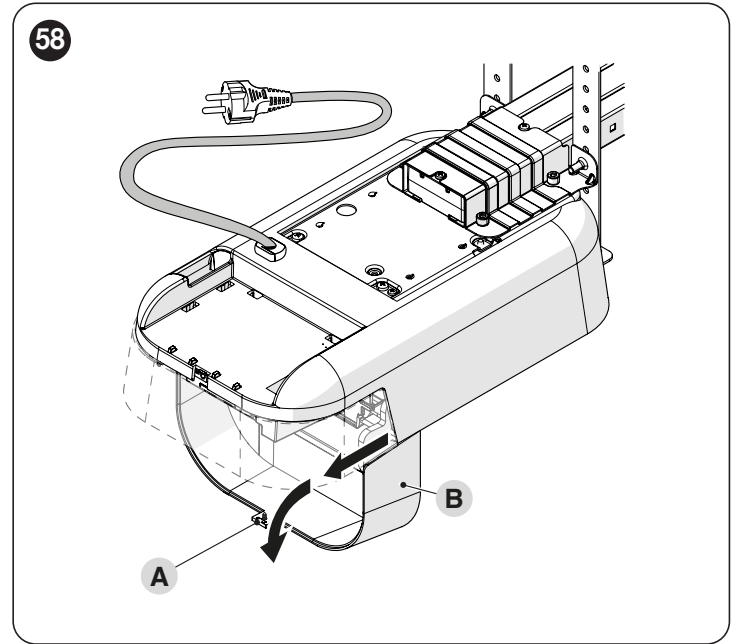

3. connect the appropriate cable to the back-up battery connector (“**Figure 59**”)

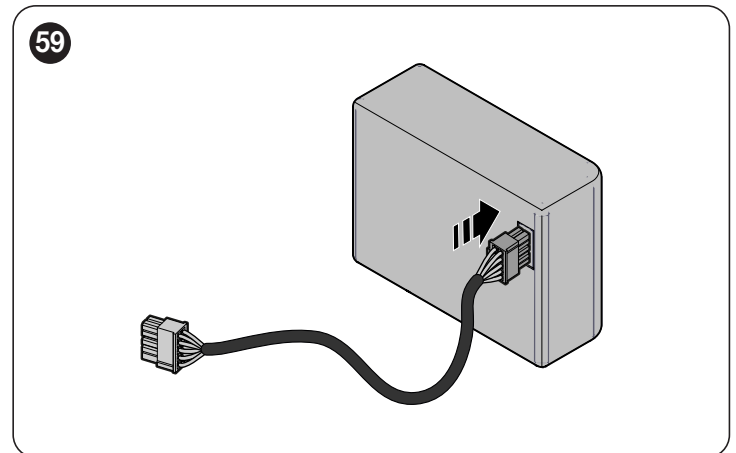

4. insert the relative connector (C) on the connector emerging from the motor compartment (“**Figure 60**”)

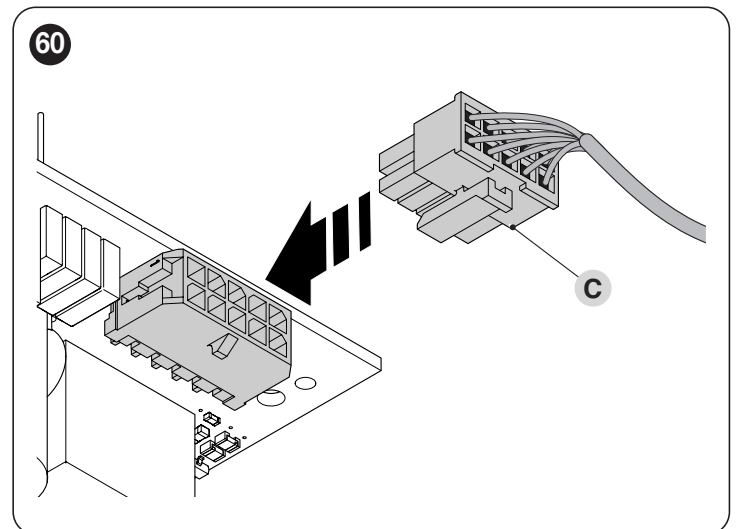

5. insert the back-up battery (D) into its housing inside the motor body ("Figure 61").

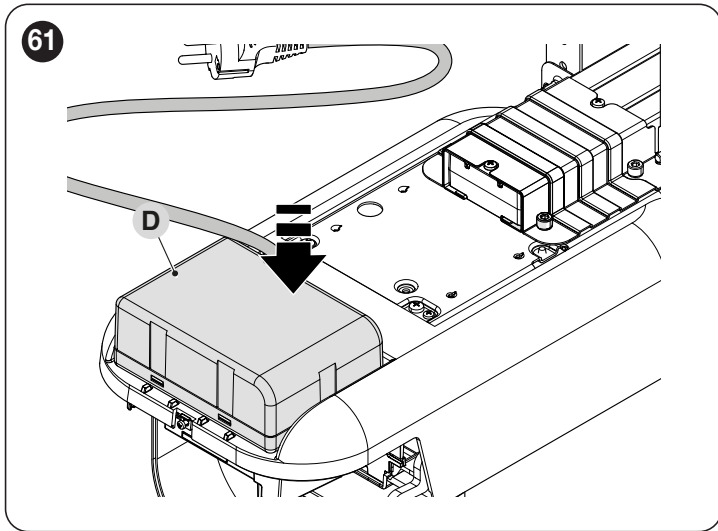

Warning! The installation of the back-up battery is advisable and useful when the stand-by mode must be activated.

Warning! In the back-up battery is used, the "All" stand-by function must not be used.

10.3 CONNECTING THE OVIEW PROGRAMMER

The control unit has a BusT4 connector to which the "Oview" programmer can be connected, through the IBT4N interface. The programmer allows for fully and rapidly managing the installation, maintenance and diagnosis of the entire automation.

To access the connector, proceed as shown in the figure and connect the connector to its relevant slot.

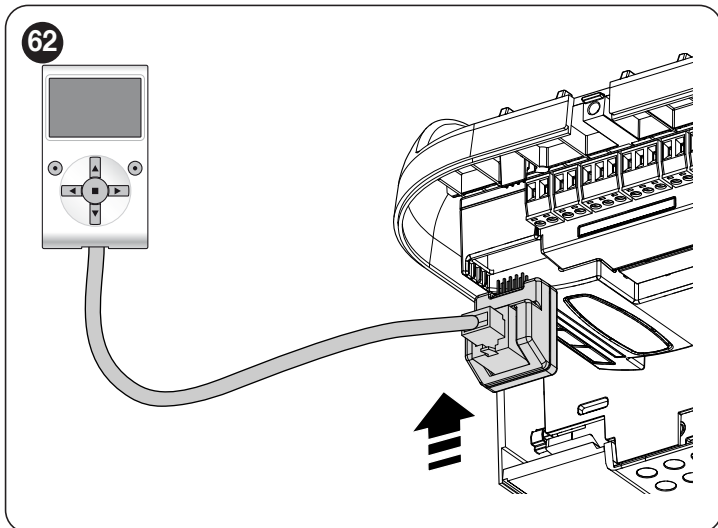

The Oview can be connected to multiple control units simultaneously (up to 16 without any particular precautions) and can be left connected to the control unit during the automation's normal operation. In this case, it can be used to send commands directly to the control unit using the specific "user" menu.

10.4 CONNECTING OTHER DEVICES

If the user needs to power external devices, such as a proximity reader for transponder cards or the light of the key selector switch, power can be tapped as shown in the figure.

In calculating the consumption in Standby Mode, the energy consumption of the accessories has not been considered. Check the respective instructions for the consumption of these accessories.

The power supply voltage is $24V \pm -30\% \div +50\%$ with a maximum available current of 100mA.

WARNING: in Standby mode the power supply drops to $21V \pm +/-10\%$ with an available power of 2W.

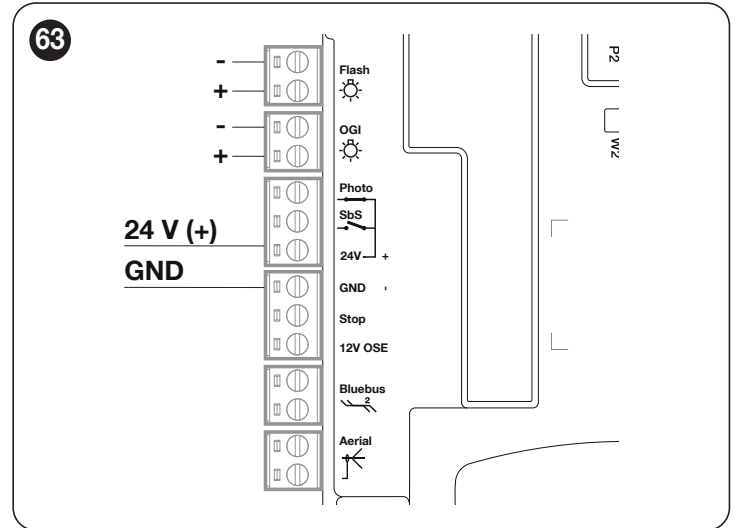

Attenzione! Carichi superiori (max 10W - 24V) devono essere collegati all'uscita Flash oppure OGI dopo averla riconfigurata con la funzione Sempre Accesa (vedi paragrafo Control unit output configuration). Se necessario disattivare la funzione Standby.

11 PARAMETERS AND PROGRAMMABLE FUNCTIONS

The following pages list all the parameters and functions of the control unit with their relative reference values. With the exception of a few parameters that are read-only, almost all the available parameters can be modified through all the compatible Nice interfaces.



WARNING: Nice reserves the right to modify the reference values and the functions without prior notice.

11.1 KEY TO THE SYMBOLS

This key shows and describes all the symbols used in the following pages.

Ⓐ = Automatic procedure

☞ = Manual procedure

📄 = Multi-board parameter

🔒 = Light door setting

🔒 = Heavy door setting

✕ = Read-only parameter (non-modifiable parameter)

11.2 COMMON PARAMETERS

Name

This parameter enables the user to assign the automation with a name other than the original, to facilitate identification (e.g. “northern gate”). It is possible to choose a name comprising maximum 24 characters, including spaces.

Series (0 → 63, default = 0)

The series is a number that has to be assigned to each gearmotor, receiver or other device potentially connectable on a BusT4 network, to define its “classification area”. Subsequently, when using automations in a complex system, all devices with the same series number can be controlled simultaneously.

Address (1 → 127, default = 3)

The address is a number that has to be assigned to each gearmotor, receiver or other device potentially connectable on a BusT4 network, to distinguish it from other devices in a series. Therefore all devices within a series must have a different address from one another.

Group (0 → 15, default = 0)

The function enables the user to assign a number to a device to be controlled (for example a gearmotor or other device potentially connectable to a BusT4 network), which enables this device to belong to a specific “command group”.

Multiple devices, even belonging to different series, can be part of the same group. Up to 14 groups of devices can be created and, in particular, the same device may be inserted in 4 different groups.

- simultaneous control of different devices inserted in a group, even if some of these belong to different series;
- use of a single receiver, installed in one of the devices belonging to the group, to control all the devices belonging to this group.

Firmware version ✕

This function can be used to view the firmware version present in a device.

Hardware version ✕

This function can be used to view the hardware version present in a device.

Serial number ✕

This function can be used to view the serial number identifying a specific device. This number is different for each device, even if of the same model.

BlueBus search

(0x0A)

This function can be used to start the learning procedure for devices connected to the BlueBus input and to the STOP input. It is also used to identify the direction of rotation of the motor (refer to the paragraph concerning the motor's rotation direction) and associate the connected expansion boards.

Position programming



After any change made to the following parameters, the control unit must restart the Automatic Force Search procedure (refer to the "Automatic force search" paragraph).

- **Cruising speed** (30 → 100 (%), default = 50 (%))

Allows for defining the speed to be used during the position programming procedure.

- **Opening** ↵ (0 → 65535, default = 65535)

Allows for programming the desired maximum opening position

- **Opening slowdown** ↵ (0 → 65535, default = 65535)

Allows for programming the opening slowdown position: near this value the automation starts decelerating before reaching the maximum opening position.

- **Partial opening** ↵ (0 → 65535, default = 65535)

Allows for programming the desired maximum opening position.

- **Closing slowdown** ↵ (0 → 65535, default = 65535)

Allows for programming the closing slowdown position: near this value the automation starts decelerating before reaching the maximum closing position.

- **Closing** ↵ (0 → 65535, default = 65535)

Allows for programming the maximum closing position which must necessarily hit the ground.

- **Exclusion position** ↵ (0 → 65535, default = 50)

Allows for programming the position within which the automation ignores any obstacle detection intervention.

- **Photo exclusion position** ↵ (0 → 65535, default = 0)

Allows for programming the position within which the automation ignores any photocell detection intervention.

- **Open discharge** (0 → 200, default = 0)

Allows for programming the reversal space (in terms of the path along the guide) on closing after the opening position has been reached. This allows for slowing down the mechanical pressure exerted on the automation.

- **Close discharge** (0 → 200, default: **SPIDER800 - SPIDER800W** = 25, **SPIDER1200BLW** = 75)

Allows for programming the reversal space (in terms of the path along the guide) on opening after the maximum closing position has been reached. This allows for slowing down the mechanical pressure exerted on the automation.



The deletion procedures described below cannot be cancelled.

This function enables the user to delete the configuration of the control unit and the data saved in it, by choosing among the following options:

– **No deletion**

No deletion takes place;

– **BlueBus devices**

Deletes the configuration of BlueBus devices, of the STOP input and of the previously acquired expansion boards;

– **Positions**

Deletes all the memorised positions;

– **Function values**

Deletes all values and adjustments of the functions pertaining to the control unit, resetting the factory values;

– **Mapping**

Allows for deleting the values of motor force absorption memorised during the execution of the manoeuvres. After starting this deletion, the automatic force search procedure must be started;

– **Delete all**

Deletes all data in the control unit memory (restoring them to the factory settings), except for the reserved parameters: series, address, hardware version, software version, serial number.

11.4 BASIC PARAMETERS

Automatic closing (ON → OFF, default = OFF)

(0x80)

This function can be used to activate automatic closing in the control unit at the end of a complete opening manoeuvre.

Function ON = the automatic closing manoeuvre starts at the end of the stand-by time programmed in the “pause time” function.

Function OFF = the Control unit is in “semi-automatic” operating mode.

Pause time (0 → 240(s), default = 30s)

(0x81)

This parameter defines the desired stand-by time that must elapse between the end of an opening manoeuvre and the start of a closing manoeuvre.



WARNING = This function is only used if the “automatic closing” function is ON.

Close again after photo

(0x86)

– **Active** (ON → OFF, default = OFF)

The function allows for keeping the automation in the open position strictly for the time required for a vehicle or people to transit. When this interval elapses the closing manoeuvre activates automatically, starting after the time set in the “stand-by time” function. (The function uses the photocells to identify the transit of people/vehicles and trigger the closing manoeuvres).

Function ON = activates the “Close again after photo” function.

Function OFF = the function is deactivated.



WARNING = The “close again after photo” function is disabled automatically if, during the manoeuvre in progress, a Stop command is sent to stop the manoeuvre.

– (OPEN FULLY → OPEN UNTIL DISENGAGEMENT, default = OPEN UNTIL DISENGAGEMENT) **mode**

This parameter is factory-set to the “open until disengagement” mode. The function has 2 operating modes:

- **open fully** = if the safety devices (photocells) intervene during a closing manoeuvre, the automation starts to perform a complete opening manoeuvre. After the “stand-by time”, the automation will autonomously start the closing manoeuvre.
- **open until disengagement** = if the safety devices (photocells) intervene during a closing manoeuvre, the automation starts to perform an opening manoeuvre, which continues until the photocells are disengaged. At this point, the manoeuvre is shut down and the automation starts the closing manoeuvre after the stand-by time programmed in the “stand-by time” function has elapsed. Note – If the “Automatic closing” function is not active, the control unit switches to the “open fully” mode.

– **Stand-by time** (0 → 250(s), default = 5s)

This function can be used to programme in the control unit the desired stand-by time that must elapse between the end of an opening manoeuvre (or the clearing of the photocells) and the start of a closing manoeuvre.

- **Active** (ON → OFF, default = OFF)

This function enables the automation to autonomously run a closing manoeuvre after a blackout. The function only activates after a blackout.

Function ON = when the power is restored the closing manoeuvre is carried out.

Function OFF = when the power is restored, the automation remains stationary.



WARNING: for safety-related reasons, when the function is active, the closing manoeuvre is preceded by a pre-flash, the duration of which is programmed through the “stand-by time” function (see below).

- (ALWAYS CLOSE → SAVE AUTOMATIC CLOSING, default = ALWAYS CLOSE) **mode**

The function has 2 operating modes:

- **always close** = after a blackout, when the power is restored and the time indicated in the “stand-by time” parameter has elapsed, the automation runs an automatic closing manoeuvre
- **save closing** = by activating this mode, when power is restored after a blackout, two results can be obtained:
 - execution of the automatic closing manoeuvre according to the time set in the “pre-flashing time” function, if the countdown of this time was in progress when the blackout occurred;
 - execution of the closing manoeuvre if an automatic closing manoeuvre was under way at the time of the blackout and had not been completed.

Note – If the automatic closing manoeuvre was cancelled before the blackout (for example, by sending the Stop command), the closing manoeuvre will not be performed when the power is restored.

- **Stand-by time** (0 → 20(s), default = 5s)

This parameter can be used to programme in the control unit the desired stand-by time that must elapse between the restart due to a blackout and the start of a closing manoeuvre. This parameter is only managed if the “ACTIVE” mode is set to ON.

Force management

- **Opening force** (10 → 100 (%), default \uparrow = 95% - \downarrow = 60%)

The function can be used to adjust the force applicable by the motor during an opening manoeuvre.

With the “heavy door” setting = the default value is 95%

With the “light door” setting = the default value is 60%

- **Open slowdown force** (10 → 100 (%), default \uparrow = 70% - \downarrow = 40%)

The function can be used to adjust the force applicable by the motor during the slowdown phase of an opening manoeuvre.

With the “heavy door” setting = the default value is 70%

With the “light door” setting = the default value is 40%

- **Closing force** (10 → 100 (%), default \uparrow = 95% - \downarrow = 60%)

The function can be used to adjust the force applicable by the motor during a closing manoeuvre

With the “heavy door” setting = the default value is 80%

With the “light door” setting = the default value is 60%

- **Close slowdown force** (10 → 100 (%), default \uparrow = 60% - \downarrow = 40%)

The function can be used to adjust the force applicable by the motor during the slowdown phase of a closing manoeuvre

With the “heavy door” setting = the default value is 60%

With the “light door” setting = the default value is 40%

- **Manual force level** (0 → 600, various defaults, 2 x \updownarrow)

This function can be used to adjust the parameters of the force that the motor must apply within the “AMP exclusion position” during the approach to the ground.

[Board 1] - Force to be applied during the door's approach to the ground (0 → 100 %)

[Board 2] - Maximum intervention time during the door's approach to the ground (0 → 600ms).

- **Force intervention time** (10 → 500, default various, 4 x )

The function controls the intervention time when the set force level is exceeded in the various manoeuvre phases.

[Board 1] - Maximum intervention time during the opening manoeuvre (default =  = 150ms -  = 150ms)

[Board 2] - Maximum intervention time during the opening slowdown phase (default  = 100ms -  = 100ms)

[Board 3] - Maximum intervention time during the closing slowdown phase (default  = 150ms -  = 150ms)

[Board 4] - Maximum intervention time during the closing slowdown phase (default  = 100ms -  = 100ms).

Sensitivity management

(0x38)

- **Detect obstacle** (ON → OFF, default = ON)



This function allows for considerably increasing the level of sensitivity with which the control unit detects the presence of an obstacle (gusts of wind, a vehicle, person, etc.).

Function ON = considerably increases the control unit's reactivity in detecting an obstacle.

Function OFF = considerably decreases the control unit's reactivity in detecting an obstacle. (Obstacle detection is only managed through the parameters set in the "Force Management" function)



Warning! The following parameters are only effective if the "detect obstacle" function is enabled (ON)

- **Open sensitivity** (10 → 100 (%), default  = 70% -  = 80%)

This function controls the force with which the control unit intervenes in detecting an obstacle during an opening manoeuvre.

- **Open slowdown sensitivity** (10 → 100(%), default  = 80% -  = 80%)

This function controls the force with which the control unit intervenes in detecting an obstacle during the slowdown phase of an opening manoeuvre.

- **Close sensitivity** (10 → 100(%), default  = 70% -  = 85%)

This function controls the force with which the control unit intervenes in detecting an obstacle during a closing manoeuvre.

- **Close slowdown sensitivity** (10 → 100(%), default  = 80% -  = 90%)

This function controls the force with which the control unit intervenes in detecting an obstacle during the slowdown phase of a closing manoeuvre.

- **Sensitivity intervention time** (10 → 500 (ms), default = various, 4 x )

The function controls the intervention time when the set force level is exceeded in the various manoeuvre phases

[Board 1] - Maximum intervention time during the opening manoeuvre (default =  = 150ms -  = 150ms)

[Board 2] - Maximum intervention time during the opening slowdown phase (default  = 100ms -  = 50ms)

[Board 3] - Maximum intervention time during the closing slowdown phase (default  = 150ms -  = 150ms)



[Board 4] - Maximum intervention time during the closing slowdown phase (default  = 100ms -  = 50ms).

Speed management

(0x40)





After any change made to the following parameters, the control unit must restart the Automatic Force Search procedure (refer to the "Automatic force search" paragraph).

- **Open speed** (25 → 100 (%), default  = 72% -  = 72%)

The function can be used to programme the motor speed during an opening manoeuvre.

- **Opening slowdown speed** (25 → 100 (%), default  = 30% -  = 30%)

The function can be used to programme the motor speed during the slowdown phase of an opening manoeuvre.

- **Closing speed** (25 → 100 (%), default  = 72% -  = 72%)

The function can be used to programme the motor speed during a closing manoeuvre.

- **Closing slowdown speed** (25 → 100 (%), default  = 30% -  = 30%)

The function can be used to programme the motor speed during the slowdown phase of a closing manoeuvre.



After any change made within this menu, the control unit must restart the Automatic Force Search procedure (refer to the “Automatic force search” paragraph).

– **Active** (ON → OFF, default = OFF)

This function is useful in the presence of high static friction (for example, snow or ice obstructing the automation) as it allows for momentarily increasing (see surge time) the speed and force used in the initial phase of a manoeuvre

Function ON = the values assigned to the functions associated with motor force and speed are (momentarily) increased to give the motor more power during the initial phase of a manoeuvre

Function OFF = normal operation

– **Surge time** (1 → 10 (s), default = 3s)

This function can be used to programme the duration of the motor's initial surge



WARNING! The function is only effective if the “surge” function is set to ON.

Pre-flashing

(0x93)

– **Active** (ON → OFF, default = OFF)

This function can be used to generate a pre-flash before the start of each manoeuvre to signal in advance a danger situation. The pre-flashing times can be configured for each manoeuvre direction

Function ON = activate the pre-flashing time between activation of the warning light and the start of an opening or closing manoeuvre

Function OFF = the warning light starts flashing when the manoeuvre starts

– **Opening time** (1 → 10 (s), default = 3s)

This function can be used to programme the flashing time that signals the imminent start of an opening manoeuvre; it is associated with the “pre-flashing” function.

– **Closing time** (1 → 10 (s), default = 3s)

This function can be used to programme the flashing time that signals the imminent start of the closing manoeuvre; it is associated with the “pre-flashing” function.

Stand-by

(0x8B)

– **Active** (ON → OFF, default = OFF)

This function can be used to reduce electrical consumption to the maximum as, after the “stand-by time” at the end of each manoeuvre, the outputs, internal peripherals and status LEDs will be switched off.

Function ON = Activates the stand-by function according to the profile chosen on “Mode”. This function is particularly useful in case of battery-powered operation

Function OFF = normal operation of the automation

– **Mode** (safety devices → BlueBus → all, all except Wi-Fi, default = safety devices)

The stand-by function has 4 operating modes:

- **safety devices** – The control unit switches off the BlueBus photocell transmitters and all LEDs, except for the BlueBus LED, which will flash more slowly instead.
- **BlueBus** – The control unit switches off the BlueBus output (the devices) and all LEDs, except for the BlueBus LED, which will flash more slowly instead.
- **all** – The control unit switches off: the BlueBus output (the devices), the control unit outputs (and the outputs of any expansion modules), the 12 V services voltage, the Wi-Fi module (where present) and all the LEDs, except for the BlueBus LED which will flash more slowly instead.
- **all except Wi-Fi** – The control unit switches off: the BlueBus output (the devices), the control unit outputs (and the outputs of any expansion modules), the 12 V services voltage, and all the LEDs, except for the BlueBus LED which will instead flash more slowly. **In this mode, the integrated Wi-Fi module is not switched off!**



WARNING! When the control unit receives any movement command, it restores normal operation. At the end of the manoeuvre, if the function is ON, the control unit will reactivate the Stand-by mode.

– **Stand-by time** (5 → 250 (s), default = 60s)

This function can be used to programme the time between the end of a manoeuvre and the start of the “stand-by” function.

Automation lock (ON → OFF, default = OFF)**(0x9A)**

This function can be used to inhibit the automation's movements.

Function ON = no type of sent command will be performed, with the exception of "High-priority step-by-step", "Unlock", "Unlock and close" and "Unlock and open" commands.

Function OFF = normal operation

Button lock (ON → OFF, default = OFF)**(0x9C)**

This function disables operation of the buttons present on the control unit. This function is particularly useful if children are present

Function ON = the control unit inhibits any command sent from the control unit buttons

Function OFF = normal operation

Internal radio inhibition (ON → OFF, default = OFF)**(0x9B)**

This function can be used to inhibit the operation of the internal radio. This function is particularly useful when using an external receiver with SM connector (optional accessories) belonging to the OXI, OXIBD, etc. families.

Function ON = disables the operation of the internal receiver

Function OFF = normal operation (integrated radio enabled)

Anti-tamper (ON → OFF, default = OFF)**(0x9F)**

This function can be used to manage the anti-tamper function following a complete closing manoeuvre.

Function ON = once the closed position has been reached, the control unit activates the "anti-tamper" mode designed to hinder potential attempts to manually open the automation. Whenever any shifting of the carriage in the opening direction is detected, the motor undertakes (automatically) to bring the automation back into the programmed closing position.

Function OFF = normal operation (anti-tamper mode disabled)

Brief reversal value (0,5 → 5 (s), default = 3 (s))**(0x31)**

This function can be used to programme the duration of the brief reversal time that the control unit commands as a safety manoeuvre after an obstacle is detected or a "Stop" command is sent.

Maximum Work Time (10 → 250 (s), default = 120 (s))**(0xA7)**

This function can be used to define the maximum duration allotted to each manoeuvre. Once this time has elapsed, the control unit performs a STOP automatically by stopping the current manoeuvre. This function is particularly useful for safeguarding the integrity of the electrical motor.

Electric lock time (0,1 → 10 (s), default = 2 (s))**(0x5A)**

This parameter can be used to programme in the control unit the desired time that must elapse between the end of a closing manoeuvre and the start of an opening manoeuvre.

Suction cup time (0,1 → 10 (s), default = 2 (s))**(0x5C)**

This parameter can be used to programme in the control unit the desired time that must elapse between the end of a closing manoeuvre and the start of an opening manoeuvre, when the suction cup is detached.

Courtesy light time (0 → 240 (s), default = 60 (s))**(0x5B)**

This parameter can be used to programme the desired duration for which the courtesy light remains lit at the end of each manoeuvre or following a "Courtesy light timer" command

12 AVAILABLE COMMANDS

The following tables list all the commands available that can be interpreted by the control unit.

These commands are divided into **BASIC** and **EXTENDED** commands and can be used from any source (radio remote control, wired inputs on terminal block, compatible Nice interfaces, etc.)

12.1 BASIC COMMANDS

Commands used in a typical installation

Table 32

DESCRIPTION OF BASIC COMMANDS	
Command configuration	Description
Open	It is the basic command for executing an opening movement.
Close	It is the basic command for executing a closing movement.
Stop	It is the basic command for interrupting the automation's movement.
Partial open 1	The control unit causes the application to run the opening manoeuvre until the position is reached as set in the "partial opening 1" function.
Step-by-Step	The control unit causes the application to run the manoeuvre following that previously executed (or still in progress), according to the order of manoeuvres given in the command's programmed sequence.

12.2 EXTENDED COMMANDS

Commands used in case of more complex needs (condominiums, companies, etc.)

Table 33

DESCRIPTION OF EXTENDED COMMANDS	
Command configuration	Description
High-priority step-by-step	The control unit causes the application to run the manoeuvre following that previously executed (or still in progress), with respect to the order of manoeuvres given in the programmed sequence. Important = This command is executed even if the control unit is set with the "lock" command.
Condominium (condominium Step-by-Step)	The control unit causes the application to run the "close - stop - open - open" sequence, until the maximum opening position is reached. The closing command can only be given once the maximum opening position has been reached.
Partial open 2	The control unit causes the application to complete the opening manoeuvre until the position is reached as set in the "partial opening 2" function.
Partial open 3	The control unit causes the application to complete the opening manoeuvre until the position is reached as set in the "partial opening 3" function.
Lock	The control unit locks and does not execute any type of command, with the exception of the "High-priority step-by-step", "Unlock", "Unlock and close" and "Unlock and open" commands.
Open and lock	The control unit causes the application to run the opening manoeuvre until the programmed "opening" position is reached and then locks the automation.
Close and lock	The control unit causes the application to run the closing manoeuvre until the programmed "closing" position is reached and then locks the automation.
Release	The control unit unlocks and restores the normal operating status (all sent commands can be executed).
Unlock and Open	Unlocks the automation and triggers an opening manoeuvre.
Unlock and Close	Unlocks the automation and triggers a closing manoeuvre.
Courtesy light ON/OFF	This command can be used to invert the on and off statuses of the courtesy light on the control unit. The courtesy light can remain lit for maximum 240 seconds (4 minutes), after which it will switch off automatically.
Timer courtesy light	This command can be used to activate the courtesy light on the control unit on a timer-controlled basis. The switch-on time can be personalised up to maximum 240 seconds (4 minutes).
Automatic opening active	This command can be used to activate the function of the BlueBus control photocells and of the inputs configured in "Condominium open" mode. For example: when the control photocells are engaged, the control unit triggers the automation to execute an opening manoeuvre.
Deactivate automatic opening	This command enables deactivation of the "automatic opening active" mode described above.

13.1 STANDARD CONFIGURATION

This section groups the available configurations that can be associated with the inputs present on the control unit (including any expansion boards).



Important! To ensure correct operation of the control unit, the inputs must be associated with the desired command and then with the desired operating mode.



WARNING! The command's behaviour is managed according to the modes specified in the "operating mode" list. The default configuration is written in bold letters.

Table 34

OPERATING MODES OF THE COMMANDS		
COMMAND	DESCRIPTION	OPERATING MODE (default mode in bold)
No command	Does not execute any command (is useful for inhibiting the interaction of an input on the terminal block)	Not applicable
Step-by-step (Input managed as NO)	The control unit causes the application to run the manoeuvre following that previously executed (or still in progress)	Open - Stop - Close - Stop Open - Stop - Close - Open Open - Close - Open - Close Condominium Step-by-Step 1 Condominium Step-by-Step 2 Step-by-step 2 Hold-to-run "Industrial" mode
Partial open 1 (Input managed as NO)	The control unit causes the application to run an opening manoeuvre until the programmed "partial opening 1" position is reached	Open - Stop - Close - Stop Open - Stop - Close - Open Open - Close - Open - Close Condominium Step-by-Step 1 Condominium Step-by-Step 2 Condominium open 1 Hold-to-run "Industrial" mode
Partial open 2 (Input managed as NO)	The control unit causes the application to run an opening manoeuvre until the programmed "partial opening 2" position is reached	Open - Stop - Close - Stop Open - Stop - Close - Open Open - Close - Open - Close Condominium Step-by-Step 1 Condominium Step-by-Step 2 Condominium open 1 Hold-to-run "Industrial" mode
Partial open 3 (Input managed as NO)	The control unit causes the application to run an opening manoeuvre until the programmed "partial opening 3" position is reached	Open - Stop - Close - Stop Open - Stop - Close - Open Open - Close - Open - Close Condominium Step-by-Step 1 Condominium Step-by-Step 2 Condominium open 1 Hold-to-run "Industrial" mode
Open (Input managed as NO)	The control unit causes the application to run the opening manoeuvre until the programmed "opening" position is reached	Open - Stop - Open Condominium open 1 Condominium open 2 Open 2 Hold-to-run open
Close (Input managed as NO)	The control unit causes the application to run the closing manoeuvre until the programmed "closing" position is reached	Close - Stop - Close Condominium close 1 Condominium close 2 Hold-to-run close
Stop (Input managed as NO)	The control unit causes the current manoeuvre to stop and executes the action programmed on "available configurations"	Stop and reversal (full) Stop and brief reversal Stop Temporary stop
Photo (Input managed as NC)	The control unit manages the input as a safety device	Stop and reversal (full) Stop and brief reversal Stop Temporary stop
Photo1 (Input managed as NC)	The control unit manages the input as a safety device	Stop and reversal (full) Stop and brief reversal Stop Temporary stop

OPERATING MODES OF THE COMMANDS		
COMMAND	DESCRIPTION	OPERATING MODE (default mode in bold)
Photo2 (Input managed as NC)	The control unit manages the input as a safety device	Stop and reversal (full) Stop and brief reversal Stop Temporary stop
Photo3 (Input managed as NC)	The control unit manages the input as a safety device	Stop and reversal (full) Stop and brief reversal Stop Temporary stop

13.2 CONFIGURATION OF THE SAFETY FUNCTIONS

The parameters listed below cannot be associated with any physical input but are used by the automation for all those functions strictly related to safety. In particular, it is possible to define which command the control unit must execute **during a manoeuvre** in the event that the **STOP** input intervenes (and all inputs configured as STOP) or if an **obstacle is detected**.

The following commands are available and configurable in the commands section.

Table 35

OPERATING MODES OF THE COMMANDS		
FUNCTION	DESCRIPTION	OPERATING MODE (default mode in bold)
Stop on opening	The control unit triggers the execution of the associated command when the input (configured as STOP) changes status during an opening manoeuvre.	Not specified Stop Stop and brief reversal Stop and reversal
Stop on closing	The control unit triggers the execution of the associated command when the input (configured as STOP) changes status during a closing manoeuvre.	Not specified Stop Stop and brief reversal Stop and reversal
Detect obstacle on opening	The control unit triggers the execution of the associated command when an obstacle is detected during an opening manoeuvre.	Not specified Stop Stop and brief reversal Stop and reversal
Detect obstacle on closing	The control unit triggers the execution of the associated command when an obstacle is detected during a closing manoeuvre.	Not specified Stop Stop and brief reversal Stop and reversal

13.3 CONTROL MODE DESCRIPTION

The underlying list describes the various operating modes of the available controls present on the control unit.

Table 36

CONTROL CONFIGURATION	
OPERATING MODE	DESCRIPTION
"Industrial" mode	The following sequence is executed: - "semi-automatic opening" - "hold-to-run close".
Hold-to-run	The opening or closing manoeuvre is executed exclusively if the command is persistent (hold-to-run). When the control is released, the control unit executes a STOP command.
Close - Stop - Close	The described sequence is executed.
Condominium close 1	The "close - close" sequence is executed. If the command is sent several times, it is not taken into account until the maximum closing position is reached.
Condominium close 2	The "close - close" sequence is executed. If the command is sent several times, it is not taken into account until the maximum closing position is reached. Warning = if the command persists for more than 2 seconds, the control unit executes a "Stop" command.
Hold-to-run close	The closing manoeuvre is executed exclusively if the command is persistent (hold-to-run). When the control is released, the control unit executes a STOP command.
Open - Stop - Close - Stop	The described sequence is executed.
Open - Stop - Close - Open	The described sequence is executed.
Open - Close - Open - Close	The described sequence is executed.
Open - Stop - Open	The described sequence is executed.
Condominium open 1	The described "open - open" sequence is executed. If the command is sent several times, it is not taken into account until the maximum opening position is reached.
Condominium open 2	The described "open - open" sequence is executed. If the command is sent several times, it is not taken into account until the maximum opening position is reached. Warning = if the command persists for more than 2 seconds, the control unit executes a "Stop" command.

OPERATING MODE	DESCRIPTION
Open 2	The opening sequence is executed. WARNING = If the command persists for more than 2 seconds, the control unit executes a "partial opening 1" command.
Hold-to-run open	The opening manoeuvre is executed exclusively if the command is persistent (hold-to-run). When the control is released, the control unit executes a STOP command.
Condominium Step-by-Step	The "close - stop - open - open" sequence is executed until the maximum opening position is reached. If another command is sent after this one, the application executes the closing manoeuvre with the same sequence.
Condominium Step-by-Step 2	The "close - stop - open - open" sequence is executed until the maximum opening position is reached. If another command is sent after this one, the application executes the closing manoeuvre with the same sequence. WARNING = If the command persists for more than 2 seconds, the control unit executes a "Stop" command
Step-by-step 2	This executes the sequence "open - stop - close - open". WARNING = If the command persists for more than 2 seconds, the control unit executes a "partial opening 1" command
Stop	When the control unit receives the command, it stops the manoeuvre in progress gradually and in a short time (not instantly).
Stop and brief reversal	The control unit stops the manoeuvre in progress and causes the automation to perform a brief reversal in the opposite direction
Stop and reversal	The control unit causes the current manoeuvre to stop and activates the full reversal in the opposite direction. The control unit causes the current manoeuvre to stop and activates the full reversal in the opposite direction.
Temporary stop	The control unit stops the current manoeuvre so long as the command remains active. When the command is no longer active, the control unit causes the application to perform an opening manoeuvre. WARNING = During the execution of the opening manoeuvre, this command is ignored
Stop	When the control unit receives the command, it instantly stops the manoeuvre in progress.
Stop and brief reversal	When the control unit receives the command, it instantly stops the manoeuvre in progress and causes the application to perform a brief reversal in the opposite direction.
Stop and reversal	When the control unit receives the command, it stops the manoeuvre in progress immediately and causes the application to perform a full reversal in the opposite direction

14 INPUT CONFIGURATION

This item groups the available configurations that can be associated with the inputs present on the control unit and on expansion boards, if any (optional accessories).

The inputs present on the control unit's terminal block are identified as:

- **INPUT 1** (0x71) (Default = **Step-by-Step**)
- **INPUT 2** (0x72) (Default = **Photo**)

The inputs available on the expansion boards are identified as:

- **INPUT 3** (0x73) (where available) (Default = **Open**)
- **INPUT 4** (0x74) (where available) (Default = **Close**)
- **INPUT 5** (0x7C) (where available) (Default = **Partial open 1**)
- **INPUT 6** (0x7D) (where available) (Default = **Emergency Open**)



In addition to the basic and extended commands described in the “*Basic parameters*” and “*Extended commands*” paragraphs, the functions indicated in the table below are included for the terminal block inputs

Table 37

INPUT CONFIGURATION	
FUNCTION	DESCRIPTION
Photo (input managed as NC)	The control unit manages the input as a safety device interpreting its switching as an intervention of the “PHOTO” photocell.
Photo 1 (input managed as NC)	The control unit manages the input as a safety device interpreting its switching as an intervention of the “PHOTO1” photocell.
Photo 2 (input managed as NC)	The control unit manages the input as a safety device interpreting its switching as an intervention of the “PHOTO2” photocell.
Photo 3 (input managed as NC)	The control unit manages the input as a safety device interpreting its switching as an intervention of the “PHOTO3” photocell.
Opening on Emergency (input managed as NC)	The control unit forces an opening command when the input opens. No command can interrupt the manoeuvre started by the emergency input and only the intervention of a safety device (photocells or STOP input) can suspend the request. Warning = If a safety device intervenes, the control unit will attempt the manoeuvre several times. In case of repeated interventions, the manoeuvre will be suspended.
Closing on Emergency (input managed as NC)	The control unit forces a closing command when the input opens. No command can interrupt the manoeuvre started by the emergency input and only the intervention of a safety device (photocells or STOP input) can suspend the request. Warning = If a safety device intervenes, the control unit will attempt the manoeuvre several times. In case of repeated interventions, the manoeuvre will be suspended.



Important – To ensure that the control unit works properly, each input must be associated with a command or function and then with the desired operating mode according to “*Control mode description*”. All the parameters are pre-set in the factory but can be modified as required.

15 OUTPUT CONFIGURATION

This section lists the functions available on the outputs present on the control unit and on expansion boards, if any (optional accessories).



ATTENTION: In Standby mode the outputs are switched off. If it is necessary to keep them active, switch off Standby mode.

15.1 CONTROL UNIT OUTPUT CONFIGURATION

This item groups the available functions that can be associated with outputs present on the control unit of an automation.

The control unit outputs are identified as:

- **OUTPUT 1** (0x51) (Default = **Warning light**)
- **OUTPUT 2** (0x52) (Default = **OIG**)



WARNING! The outputs are limited to 24 VDC – 10 W

Table 38

CONTROL UNIT OUTPUT CONFIGURATION		
FUNCTION	ID	DESCRIPTION
Not specified (None)		The control unit forces the status of the output to off. No command or interaction of the control unit can switch the output's status.
Sca/OIG (Open Gate Indicator)	(0x01)	The programmed indicator light indicates the operating statuses of the control unit: light off = application in maximum Closing position; slow flashing = application in Opening manoeuvre execution phase; quick flashing = application in Closing manoeuvre execution phase; light permanently on = application stopped into a position different to maximum Opening position.
Gate open	(0x02)	The programmed indicator light indicates the operating statuses of the control unit: light on = application in maximum Opening position light off = application in other positions.
Gate closed	(0x03)	The programmed indicator light indicates the operating statuses of the control unit: light on = application in maximum Closing position; light off = application in other positions. Output active 24 VDC / max 10 W.
Maintenance	(0x04)	The programmed light indicates the count of manoeuvres completed and therefore the need (or not) for system maintenance operations: light on for 2 seconds at the start of the opening manoeuvre = number of manoeuvres below 80%; light flashing during execution of the entire manoeuvre = number of manoeuvres between 80 and 100%; light always flashing = number of manoeuvres above 100%.
PhotoTest	(0x25)	The output powers the relay photocells and verifies their integrity when the manoeuvre starts. The type of interaction is strictly linked to the configuration of the inputs configured as PHOTO, PHOTO1 and PHOTO2.
Warning light	(0x05)	This function enables the warning light to indicate the execution of the current manoeuvre. The flashes occur at regular intervals (0,5 seconds lit; 0,5 seconds off). This mode allows for commanding the output with a voltage of 12Vdc.
Warning light1	(0x13)	This function enables the output to switch from on to off regardless of the status of the motor. The activations occur at regular intervals (0,5 seconds on; 0,5 seconds off).
Warning light 24V	(0x17)	This function enables the warning light to indicate the execution of the current manoeuvre. The flashes occur at regular intervals (0,5 seconds lit; 0,5 seconds off). This mode commands the output with a voltage of 24Vdc.
Courtesy light	(0x06)	The output follows the status of the courtesy light present on the control unit.
Door status	(0x1E)	The output follows the status of the motor's movement regardless of the direction of motion: light on = motor manoeuvring light off = motor stationary.
Presence	(0x23)	With the automation stationary, the intervention of any photocell activates the output for 5 seconds (the time cannot be programmed).
Electric lock 1 [note 1]	(0x07)	With this function programmed, when an opening manoeuvre is performed the electric lock activates for a duration equal to the value set in the "electric lock time" function.
Electric locking device 1 [note 1]	(0x09)	On the output it is possible to connect an electric locking device with latch (versions with electric magnet only or without electronic devices). During the opening manoeuvre, the electric locking device activates and remains active to free the automation and perform the manoeuvre. During the closing manoeuvre, ensure that the electric locking device re-engages mechanically.
Always on	(0x16)	This function keeps the output always switched on. In Standby mode, the output is switched off.

CONTROL UNIT OUTPUT CONFIGURATION		
FUNCTION	ID	DESCRIPTION
Suction cup 1 [note 1]	(0x0B)	With this function programmed, the output activates when the application is in the maximum closing position. Note – The output is disabled in all other situations. When the suction cup deactivates, before an opening manoeuvre is started, the time interval programmed in the “suction cup time” function intervenes
Unidirectional traffic light	(0x1A)	If programmed as “Unidirectional traffic light”: light on = application in maximum opening position light off = application in any other position.
Red traffic light	(0x0D)	This function indicates that the application is active during the phases of a closing manoeuvre: slow flashing = execution of Closing manoeuvre; light permanently on = application in maximum closing position; light off = application in other positions.
Green traffic light	(0x0E)	This function indicates that the application is active during the phases of an opening manoeuvre: slow flashing = execution of opening manoeuvre; light permanently on = application in maximum opening position; light off = application in other positions.
Buzzer	(0x1D)	This function activates the buzzer if the UL325 function is active (where available).
Radio channel no. 1 Radio channel no. 2 Radio channel no. 3 Radio channel no. 4	(0x0F) (0x10) (0x11) (0x12)	If this radio channel is set for the configuration of the output, this output activates when a command is set with the transmitter and remains in this state until the command persists. It is useful if external devices are installed (for example, an auxiliary light) in the same system to be controlled with a single transmitter. WARNING = If this radio channel is not free on the control unit receiver, due to having being previously memorised with a command, the control unit will only activate the programmed output when the channel is activated with the transmitter, ignoring the command towards the motor. Warning = This function is not currently available for transmitters of the BiDi family.

[note 1] = Only devices containing the electric magnet only can be connected

15.2 OUTPUT CONFIGURATION - EXPANSION MODULES

This item groups the available functions that can be associated with outputs present on the expansion boards.
The expansion board outputs are identified as:

- **OUTPUT 3** (0x53) (where available) (Default = **Unidirectional traffic light**)
- **OUTPUT 4** (0x54) (where available) (Default MLAE22 = **Courtesy light**, MLEA44 = **Green traffic light**)
- **OUTPUT 5** (0x55) (where available) (Default = **Red traffic light**)
- **OUTPUT 6** (0x56) (where available) (Default = **Phototest**)



WARNING! The outputs are limited to 24 VDC – 10 W

Table 39

CONFIGURATION OF THE EXPANSION BOARD OUTPUTS		
FUNCTION	ID	DESCRIPTION
Not specified (None)		The control unit forces the status of the output to off. No command or interaction of the control unit can switch the output's status.
Sca/OGI (Open Gate Indicator) [note 2]	(0x01)	The programmed indicator light indicates the operating statuses of the control unit: light off = application in maximum Closing position; slow flashing = application in Opening manoeuvre execution phase; quick flashing = application in Closing manoeuvre execution phase; light permanently on = application stopped into a position different to maximum Opening position.
Gate open	(0x02)	The programmed indicator light indicates the operating statuses of the control unit: light on = application in maximum Opening position light off = application in other positions.
Gate closed	(0x03)	The programmed indicator light indicates the operating statuses of the control unit: light on = application in maximum Closing position; light off = application in other positions. Output active 24 VDC / max 10 W.
Maintenance [note 2]	(0x04)	The programmed light indicates the count of manoeuvres completed and therefore the need (or not) for system maintenance operations: light on for 2 seconds at the start of the opening manoeuvre = number of manoeuvres below 80%; light flashing during execution of the entire manoeuvre = number of manoeuvres between 80 and 100%; light always flashing = number of manoeuvres above 100%.

CONFIGURATION OF THE EXPANSION BOARD OUTPUTS

FUNCTION	ID	DESCRIPTION
PhotoTest	(0x25)	The output powers the relay photocells and verifies their integrity when the manoeuvre starts. The type of interaction is strictly linked to the configuration of the inputs configured as PHOTO, PHOTO1 and PHOTO2.
Warning light1 [note 2]	(0x13)	This function enables the output to switch from on to off regardless of the status of the motor. The activations occur at regular intervals (0,5 seconds on; 0,5 seconds off).
Warning light 24V	(0x17)	This function enables the warning light to indicate the execution of the current manoeuvre. The flashes occur at regular intervals (0,5 seconds lit; 0,5 seconds off). This mode commands the output with a voltage of 24Vdc.
Courtesy light	(0x06)	The output follows the status of the courtesy light present on the control unit.
Presence	(0x23)	With the automation stationary, the intervention of any photocell activates the output for 5 seconds (the time cannot be programmed).
Electric lock 1 [note 1] [note 3]	(0x07)	With this function programmed, when an opening manoeuvre is performed the electric lock activates for a duration equal to the value set in the "electric lock time" function.
Electric locking device 1 [note 1] [note 2]	(0x09)	On the output it is possible to connect an electric locking device with latch (versions with electric magnet only or without electronic devices). During the opening manoeuvre, the electric locking device activates and remains active to free the automation and perform the manoeuvre. During the closing manoeuvre, ensure that the electric locking device re-engages mechanically.
Suction cup 1 [note 1] [note 2]	(0x0B)	With this function programmed, the output activates when the application is in the maximum closing position. Note – The output is disabled in all other situations. When the suction cup deactivates, before an opening manoeuvre is started, the time interval programmed in the "suction cup time" function intervenes.
Unidirectional traffic light	(0x1A)	If programmed as "Unidirectional traffic light": light on = application in maximum opening position light off = application in any other position.
Red traffic light	(0x0D)	This function indicates that the application is active during the phases of a closing manoeuvre: slow flashing = execution of Closing manoeuvre; light permanently on = application in maximum closing position; light off = application in other positions.
Green traffic light	(0x0E)	This function indicates that the application is active during the phases of an opening manoeuvre: slow flashing = execution of opening manoeuvre; light permanently on = application in maximum opening position; light off = application in other positions.
Buzzer	(0x1D)	This function activates the buzzer if the UL325 function is active (where available).
Radio channel no. 1 Radio channel no. 2 Radio channel no. 3 Radio channel no. 4	(0x0F) (0x10) (0x11) (0x12)	If this radio channel is set for the configuration of the output, this output activates when a command is set with the transmitter and remains in this state until the command persists. It is useful if external devices are installed (for example, an auxiliary light) in the same system to be controlled with a single transmitter. WARNING = If this radio channel is not free on the control unit receiver, due to having being previously memorised with a command, the control unit will only activate the programmed output when the channel is activated with the transmitter, ignoring the command towards the motor. Warning = This function is not currently available for transmitters of the BiDi family.

[note 1] = Only devices containing the electric magnet only can be connected.

[note 2] = This function is not available on the power output.

[note 3] = Use an external relay and a back-up power supply.



All technical specifications stated in this section refer to an ambient temperature of 20°C (± 5°C). Nice S.p.A. reserves the right to apply modifications to the product at any time when deemed necessary, without altering its functions and intended use.

Table 40

GEARMOTOR TECHNICAL SPECIFICATIONS		
Description	SPIDER800 - SPIDER800W	SPIDER1200BLW
Product type	Electromechanical gearmotor for the automatic movement of garage doors for residential use, inclusive of electronic control unit	Electromechanical gearmotor for the automatic movement of garage doors for residential use, inclusive of electronic control unit
Power supply	230V~ (+/-10%) 50/60Hz	230V~ (+/-10%) 50/60Hz
Power supply /V1	120V~ (+/-10%) 50/60Hz	120V~ (+/-10%) 50/60Hz
Maximum torque (corresponding to the maximum force)	14.4 Nm (800 N)	21.6 Nm (1200N)
Maximum force	800 N	1200 N
Nominal force	400 N	600 N
Standby Mode Power (W)	0.5	1.5
Power in Standby Mode No WiFi (for models with built-in WiFi)	1.5	1.5
Maximum power consumption (W)	280	350
Nominal power consumption (W)	180	240
Maximum speed (m/s)	0,20	0,16
Protection rating (IP)	40	40
Operating temperature (min/max °C)	-20°C ... +55°C	-20°C ... +55°C
Insulation class	I	I
Maximum no. of cycles/day	50	150
Maximum continuous operating time	4 minutes	4 minutes
Dimensions (mm)	225x395x105	225x395x105
Weight (kg)	4,9	6,7
Emergency power supply	With optional accessory PSS124	With optional accessory PSS124
Courtesy light	Integrated with LED	Integrated with LED
FLASH output [Note 1]	Output for connecting the warning light (max 10 W)	Output for connecting the warning light (max 10 W)
OGI output [Note 1]	Output for connecting the Open Gate Indicator (max 10 W)	Output for connecting the Open Gate Indicator (max 10 W)
STOP input	For normally closed or normally open contacts, 8.2 KΩ fixed resistor contacts or OSE optical devices with self-learning function (any variation from the memorised status triggers the "STOP" command)	For normally closed or normally open contacts, 8.2 KΩ fixed resistor contacts or OSE optical devices with self-learning function (any variation from the memorised status triggers the "STOP" command)
SbS input	For normally open contacts (closing of the contact triggers the STEP-BY-STEP command)	For normally open contacts (closing of the contact triggers the STEP-BY-STEP command)
PHOTO input	For normally closed contacts (the contact's opening triggers the photocell reopening command)	For normally closed contacts (the contact's opening triggers the photocell reopening command)
Radio ANTENNA input	52 Ω for RG58-type cable or similar	52 Ω for RG58-type cable or similar
Programming input	For accessories compatible with the IBT4N interface	For accessories compatible with the IBT4N interface
Programmable functions	8 type ON-OFF functions and 8 adjustable functions	8 type ON-OFF functions and 8 adjustable functions
Self-learning functions	Self-learning of the type of "STOP" device (Normally Open, Normally Closed contact or 8.2 kΩ resistor, optical sensitive edge) Expansion board and calculation of the slowdown and partial opening points	Self-learning of the type of "STOP" device (Normally Open, Normally Closed contact or 8.2 kΩ resistor, optical sensitive edge) Expansion board and calculation of the slowdown and partial opening points
Stand-By mode	Automatic: 5 minutes after the end of the main functions	Automatic: 5 minutes after the end of the main functions
Use in highly acid, saline or potentially explosive atmosphere	No	No

Note 1 The output can be programmed with other functions (see "Table 21" on page 28 29) or through the Oview programmer.

Table 41

INCORPORATED RADIO RECEIVER TECHNICAL SPECIFICATIONS	
Description	Technical specification
Product type	Incorporated Bidirectional receiver
Decoding	OXIBD: "BD" / "O-code"
Memorisable transmitters	Up to 100 if memorised in "Mode 1"
Input impedance	50 Ω
Reception frequency	433.92 MHz
Transmission frequency	433.92 MHz (only BD)
Sensitivity	- 108 dBm
Radiated power (ERP)	< 10 mW (OXIBD)

Table 42

TECHNICAL CHARACTERISTICS OF THE INTEGRATED WI-FI MODULE (WHERE AVAILABLE)	
Description	Technical specification
Type of Wi-Fi interface with internal antenna	802.11b/g/n – 2.4GHz
Wi-Fi security	OPEN/WEP/WPA-PSK/WPA2-PSK
Bluetooth ®	v4.2 BR/EDR/BLE
Radiated power (EIRP)	P < 20 dBm

Table 43

GUIDE TECHNICAL SPECIFICATIONS							
Description	SR32C	SR16C	SR08C	SR32B	SR16B	SR08B	SR40B
Product type	single galvanised steel profile	2-piece galvanised steel profile	single galvanised steel profile	single galvanised steel profile	2-piece galvanised steel profile	single galvanised steel profile	2 piece galvanised steel profile
Guide length	3200 mm	3200 (1600x2) mm	800 mm*	3200 mm	3200 (1600x2) mm	800 mm*	4000 mm*
Useful stroke	2800 mm	2800 mm	3500 mm**	2800 mm	2800 mm	3500 mm**	3500 mm**
Guide height	30 mm	30 mm	30 mm	30 mm	30 mm	30 mm	30 mm
Belt height	-	-	-	10 mm	10 mm	10 mm	10 mm
Belt/chain length	6261 mm	6261 mm	7861 mm	6260 mm	6260 mm	7856 mm	7856 mm

* To be used with a 3.2 m guide to reach a length of 4 m.

** Data referred to the 4 m guide.

EU Declaration of Conformity and declaration of incorporation of “partly completed machinery”

The EU declaration of conformity can be downloaded from the website www.niceforyou.com

Nice Type **SPIDER800**
 Made in Italy P/N: SPR800R30
 Nice SpA Via Callalta,1 31046 Oderzo TV Italy

200W | 230V 50/60HZ
 800N | -20°C | +55°C
 IP40 | 4min | 20Cycles/h(@55°C)
 S/N: SERIALNUMBER YEAR

CE 0682 UK EAC



PROGRAMMING INSTR. MANUAL

Nice Type **SPIDER800W**
 Made in Italy P/N: SPR800WR30
 Nice SpA Via Callalta,1 31046 Oderzo TV Italy

200W | 230V 50/60HZ
 800N | -20°C | +55°C
 IP40 | 4min | 20Cycles/h(@55°C)
 S/N: SERIALNUMBER YEAR

CE 0682 UK EAC



PROGRAMMING INSTR. MANUAL

Nice Type **SPIDER1200BLW**
 Made in Italy P/N: SPR1200R30
 Nice SpA Via Callalta,1 31046 Oderzo TV Italy

350W | 230V 50/60HZ
 1200N | -20°C | +55°C
 IP40 | 4min | 40Cycles/h(@55°C)
 S/N: SERIALNUMBER YEAR

CE 0682 UK EAC



PROGRAMMING INSTR. MANUAL

18 PRODUCT MAINTENANCE

The automation must be subjected to maintenance work on a regular basis in order to guarantee it lasts.



Maintenance must be carried out strictly in compliance with the safety provisions provided in this manual and in accordance with the laws and regulations in force.

To carry out maintenance on the gearmotor:

1. schedule maintenance interventions within maximum 6 months or after maximum 3.000 manoeuvres from the previous maintenance intervention
2. disconnect all power supplies, including any back-up batteries
3. check for any deterioration in the materials making up the automation, with special emphasis on erosion or oxidation of the structural parts; replace any parts that are not to standard
4. check the state of wear of moving parts: pinion, rack and all gate leaf components; replace any worn parts
5. connect the power supplies again and run all the tests and checks described in the "**Testing**" paragraph (page 19).

19 PRODUCT DISPOSAL



This product is an integral part of the operator and must therefore be disposed of with it.

As with the installation, only qualified personnel must dismantle the product at the end of its life.

This product is composed of different types of materials. Some of these materials can be recycled; others must be disposed of. Please enquire about the recycling or disposal systems in place in your local area for this type of product.



WARNING

Some parts of the product may contain polluting or dangerous substances. If not disposed of correctly, these substances may have a damaging effect on the environment and human health.



As indicated by the symbol shown here, this product must not be disposed of with household waste. Separate the waste for disposal and recycling, following the methods stipulated by local regulations, or return the product to the seller when purchasing a new product.



WARNING

Local regulations may impose heavy penalties if this product is not disposed of in compliance with the law.

NOTES

A series of horizontal dashed lines for writing notes.

A series of 20 horizontal dashed lines spanning the width of the page, intended for handwriting practice.

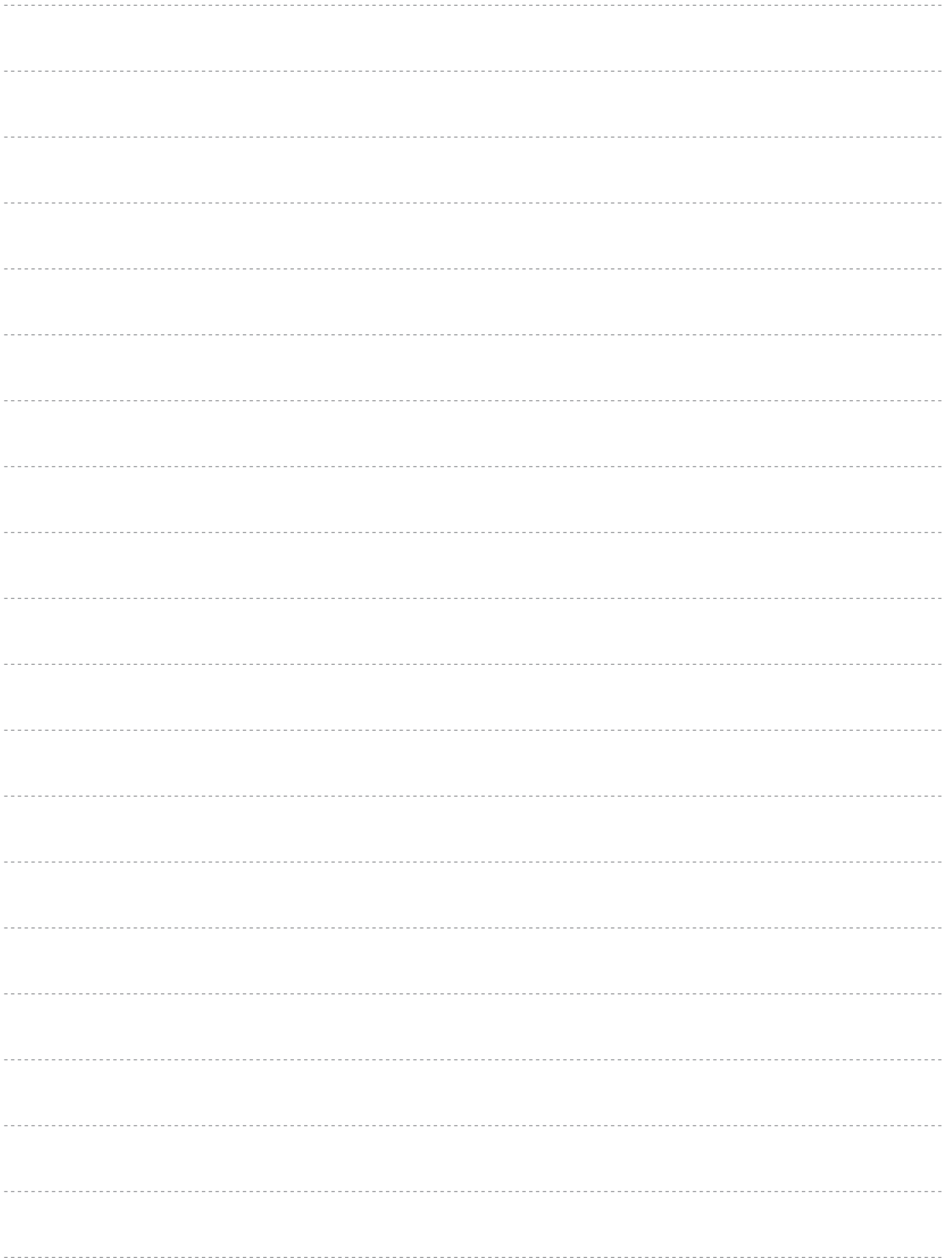

Before using the automation system for the first time, ask the installer to explain the origin of residual risks and take a few minutes and read this instructions manual and related warnings handed to you by the installer. Keep the manual for consultation when in doubt and ensure supply to new owners of the automation.



WARNING!

Your automation is a machine that faithfully executes commands imparted by the user. Negligence and improper use may lead to dangerous situations:

- do not manoeuvre the gate if there are people, animals or objects within its range of operation
- it is strictly forbidden to touch parts of the automation while it is moving
- the photocells should not be regarded as actual safety devices but only as auxiliary safety devices. They are designed using highly reliable technology, but in extreme conditions may be subject to malfunctions or potential faults, and in certain cases these faults might not be immediately evident
- periodically check that the photocells work properly.



IT IS STRICTLY FORBIDDEN to transit while the automation is closing! Transit is allowed only if the automation is fully open and stationary.



CHILDREN

An automation system guarantees a high degree of safety. With its detection systems, it can control and guarantee the gate's movement in the presence of people or objects. It is nonetheless advisable to forbid children from playing near the automation and not to leave remote controls near them to prevent any unwanted activation of the system. The automation is not a toy!

The product is not intended for use by persons, including children, with limited physical, sensory or mental capacities, or who lack experience or knowledge, unless supervised or trained in the use of the product by a person responsible for their safety.

Anomalies: if the automation shows any signs of anomalous behaviour, disconnect the power supply to the system and manually unlock the motor (see instructions at the end of the chapter) to manoeuvre the automation manually. Do not attempt any repairs personally, but contact your trusted installer.



Do not modify the system or the programming and adjustment parameters of the control unit: your installer is exclusively responsible for these operations.

Failure or lack of power supply: while waiting for the installer to intervene or the electricity to be restored, if the system is not equipped with emergency power supplies, the automation can nonetheless be used by manually unlocking the motor (see the instructions at the end of the chapter) and moving the automation manually.

Safety devices out of order: the automation can also be used when one or more safety devices are defective or out of order. The automation can be controlled in **"Hold-to-run"** mode in the following way:

1. send a command to operate the automation using a transmitter or key selector, etc. If everything works normally, the automation will move regularly, otherwise the warning light will flash a few times and the manoeuvre will not start (the number of flashes depends on the reason for which the manoeuvre cannot start)
2. in this case, within 3 seconds press the control again and hold it down
3. after roughly 2 seconds, the automation will complete the requested manoeuvre in **"Hold-to-run"** mode, in other words, it will continue to move so long as the control is held down.



If the safety devices are out of order, have the system repaired as soon as possible by a qualified technician.

The test, periodic maintenance and any repairs must be documented by the person carrying out the work and the documents must be stored by the owner of the automation. The only interventions the user may carry out periodically include cleaning of the photocell glass components (use a soft and slightly damp cloth) and removing any leaves or stones that may obstruct the automation.



Before carrying out any maintenance operations, the user of the automation must manually unlock the motor to prevent anyone from accidentally triggering the automation's movement (see the instructions at the end of the chapter).

Maintenance: in order to ensure constant levels of safety and the longest useful life for the automation, routine maintenance must be carried out (at least every 6 months).



Only qualified personnel is authorised to carry out checks, maintenance operations and repairs.

Disposal: at the end of its useful life, the automation must be dismantled by qualified personnel and the materials must be recycled or disposed of in compliance with the local regulations in force.

Replacing the remote control battery: if your remote control appears to be working poorly after some time, or stops working altogether, it may simply depend on flat batteries (depending on how much the device is used, the batteries may last from several months to over a year). You will notice this by the fact that the indicator light signalling the transmission fails to light up, is weak or lights up only for a short time. Before contacting the installer, try replacing the battery with that of another transmitter that works properly: if the anomaly is resolved, simply replace the flat battery with one of the same type.

Unlocking and manual movement

⚠ The gate can only be unlocked once the leaf has come to a standstill.

The gearmotor is equipped with a mechanical unlocking device that can be used to open and close the door manually.

These manual operations should only be performed in case of a power outage, malfunctions or during the installation phases.

To unlock the device:

1. pull the releasing cord (A) ("Figure 25")

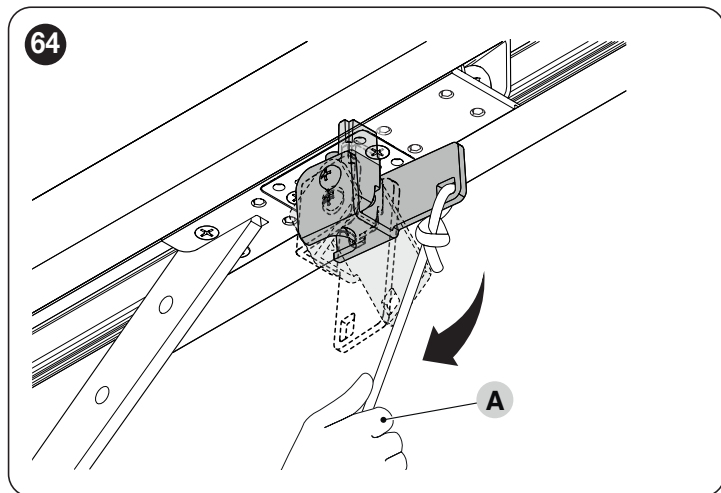

2. the door can now be moved manually to the desired position.

To lock the device:

1. pull the releasing cord (A) ("Figure 26")

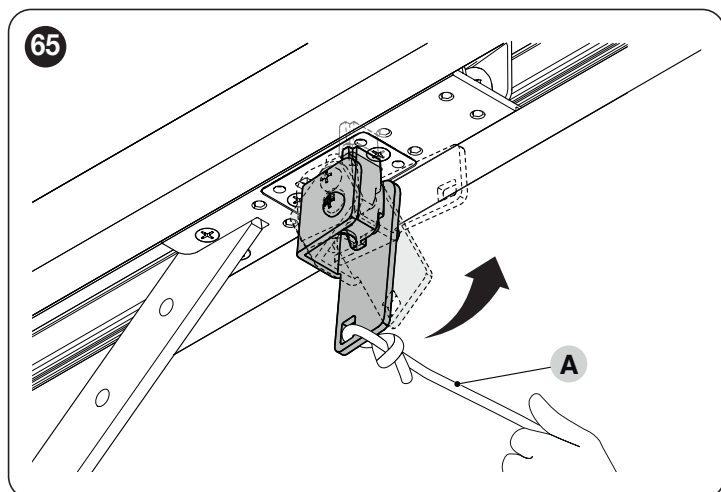

2. manually move the door to align the lower part of the motor carriage with the upper part so that it slots into place.



Nice SpA
Via Callalta, 1
31046 Oderzo (TV)
Italia

www.niceforyou.com

IS0748A03END_13-06-2025