

Soon

SO2000

CE
EAC



Garage door opener

EN - Instructions and warnings for installation

Nice

CONTENTS

1	GENERAL SAFETY WARNINGS AND PRECAUTIONS	2
1.1	General warnings	2
1.2	Installation warnings	3
2	PRODUCT DESCRIPTION AND INTENDED USE	3
2.1	List of constituent parts	3
3	INSTALLATION	4
3.1	Pre-installation checks	4
3.2	Product usage limits	4
3.2.1	Product durability	4
3.3	Product identification and overall dimensions	5
3.4	Receipt of the product	5
3.5	Pre-installation works	6
3.6	Installing the gearmotor	7
3.7	Manually unlocking and locking the gearmotor	8
4	ELECTRICAL CONNECTIONS	8
4.1	Preliminary checks	8
4.2	Wiring diagram and description of connections	9
4.2.1	Wiring diagram	9
4.2.2	Description of connections	9
4.3	Addressing of devices connected with the BlueBUS system	10
4.3.1	FT210B photosensor	11
5	FINAL CHECKS AND START-UP	11
5.1	Power supply connection	11
5.2	Device learning	11
5.3	Learning of the door opening and closing positions	11
5.4	Checking the door movement	13
5.5	Connecting other devices	13
6	TESTING AND COMMISSIONING	13
6.1	Testing	14
6.2	Commissioning	14
7	PROGRAMMING	15
7.1	Using the programming buttons	15
7.2	Level 1 programming (ON-OFF)	16
7.2.1	Level 1 programming procedure	16
7.3	Level 2 programming (adjustable parameters)	17
7.3.1	Level 2 programming procedure	17
7.4	Programming the direction	19
7.5	Resetting the encoder position	19
7.6	Special functions	19
7.6.1	"Always open" function	19
7.6.2	"Move anyway" function	19
7.6.3	"Maintenance notice" function	19
7.7	Verifying the number of manoeuvres completed	20
7.8	Manoeuvre counter resetting	20
7.9	Memory deletion	20
8	TROUBLESHOOTING GUIDE	21
8.1	Troubleshooting	21
8.2	Anomaly log	22
8.3	Signalling through warning light	22
8.4	Signals on the control unit	23
9	FURTHER DETAILS (Accessories)	25
9.1	Modifying the STOP input configuration	25
9.2	Connecting an SM-type radio receiver	25
9.3	Connecting and installing the emergency power supply	26
9.4	Wi-Fi connection	27
9.4.1	BiDi-Wi-Fi interface	27
9.5	Connecting the Solemyo solar energy system	28
10	PRODUCT MAINTENANCE	29
11	PRODUCT DISPOSAL	29
12	TECHNICAL SPECIFICATIONS	30
13	CONFORMITY	31
INSTRUCTIONS AND WARNINGS		33

1.1 GENERAL WARNINGS



Prior to installing the appliance, carefully read and observe these instructions, since incorrect installation can cause serious harm to people and damage to the appliance. Store them with care.



According to the latest European legislation, an automated device must be constructed in conformity to the harmonised rules specified in the current Machinery Directive, which allow for declaring the presumed conformity of the automation. Consequently, all the operations for connecting the product to the mains electricity, its commissioning and maintenance must be carried out exclusively by a qualified and expert technician.



In order to avoid any danger from inadvertent resetting of the thermal cut-off device, this appliance must not be powered through an external switching device, such as a timer, or connected to a supply that is regularly powered or switched off by the circuit.

WARNING! Please abide by the following warnings:

- Before commencing the installation, check the "Product technical specifications", in particular whether this product is suitable for automating your guided part. Should it not be suitable, do NOT proceed with the installation.
- The product cannot be used before it has been commissioned as specified in the "Testing and commissioning" chapter.
- Before proceeding with the product's installation, check that all the materials are in good working order and suited to the intended applications.
- The product is not intended for use by persons (including children) with reduced physical, sensory or mental capacities, nor by anyone lacking sufficient experience or familiarity with the product.
- Children must not play with the appliance.
- Do not allow children to play with the product's control devices. Keep the remote controls out of reach of children.
- The system's power supply network must include a disconnection device (not supplied) with a contact opening gap permitting complete disconnection under the conditions envisaged by Overvoltage Category III.
- Handle the product with care during installation, taking care to avoid crushing, denting or dropping it, or allowing contact with liquids of any kind. Keep the product away from sources of heat and naked flames. Failure to observe the above can damage the product, and increase the risk of danger or malfunction. Should this happen, stop installation immediately and contact Customer Service.
- The manufacturer declines all liability for damages to property, objects or people resulting from failure to observe the assembly instructions. In such cases, the warranty for material defects shall not apply.
- The weighted sound pressure level of the emission A is lower than 70 dB(A).

- Cleaning and maintenance reserved for the user must not be carried out by unsupervised children.
- Before intervening on the system (maintenance, cleaning), always disconnect the product from the mains power supply and from any batteries.
- Inspect the system frequently, in particular the cables, springs and supports to detect any imbalances and signs of wear or damage. Do not use the product if it needs to be repaired or adjusted, because defective installation or incorrect balancing of the automation can lead to injuries.
- The packing materials of the product must be disposed of in compliance with local regulations.
- The product must not be installed outdoors.
- Keep an eye on moving doors and do not let anyone go near them until they have opened or closed fully.
- Be careful when activating the manual unlocking device (manual manoeuvre), as an open door may fall suddenly due to weak or broken springs, or if it is unbalanced.
- Every month, check that the drive motor reverses when the door encounters a 50 mm-high object placed on the ground. If necessary, readjust the door and check it again, as incorrect adjustment is potentially dangerous (for drive motors incorporating a trapping safety system that intervenes when the door's lower edge encounters an obstacle).
- Motor with **fixed** power cable: the power cable **cannot be replaced**. If the cable is damaged, the appliance must be scrapped.
- Motor with **removable** power supply cable with dedicated connector: if the power supply cable is damaged, it **must be replaced** by the manufacturer or by the latter's technical assistance service, or nonetheless by a similarly qualified person, so as to prevent any risk.

1.2 INSTALLATION WARNINGS

- Prior to installing the drive motor, check that the door is in good working order, correctly balanced and that it opens and closes properly.
- Before installing the drive motor, remove all unnecessary ropes or chains and deactivate any equipment not required for motorised operation, such as locking devices.
- Install the manoeuvre device for manual unlocking at less than 1.8 m above the ground. NOTE - If removable, the manoeuvre device must be kept next to the door when removed.
- Make sure that the control elements are kept far from moving parts but nonetheless directly within sight. Unless a selector is used, the control elements must be installed at least 1.5 m above the ground and must not be accessible.
- Permanently attach the trapping hazard warning labels in a highly visible location or near the fixed control devices (if present).
- Permanently attach the manual unlock (manual manoeuvre) label close to the manoeuvring element.

- After installation, make sure that the motor prevents or stops opening of the door when the latter is loaded with a 20-kg weight secured to the centre of its bottom edge (for drive motors that can be used with doors having opening widths exceeding 50 mm).
- **WARNING!** After installation, make sure that the mechanism is properly adjusted and that the motor reverses when the door collides with a 50 mm-tall object placed on the ground (for drive motors incorporating a trapping safety system that intervenes when the bottom edge of the door encounters an obstacle). Following installation, check and ensure that no door parts obstruct public roadways or pavements.

2 PRODUCT DESCRIPTION AND INTENDED USE

SO2000 is an electromechanical actuator for automating sectional doors up to 20 m². Thanks to the cable outlet shaft, it ensures easy connection with the spring support shaft of most sectional doors available on the market.

The control unit supplied with the product, besides powering the DC motor, ensures optimal adjustment of the gearmotor torque and speed, precise measurement of the positions, gradual starting and closing, and obstacle detection. It is also equipped with a maintenance indicator to enable recording of the manoeuvres performed by the gearmotor during its lifetime.

The unlocking mechanism, activated from the ground, disengages the motor from the gearmotor body.



CAUTION! – Any use other than that specified herein or in environmental conditions other than those stated in this manual is to be considered improper and is strictly forbidden!

This product complies with the “Standby” regulation. The product goes into Standby Mode 5 minutes after a successfully completed operation.

2.1 LIST OF CONSTITUENT PARTS

“**Figure 1**” shows the main parts making up the **Soon**.

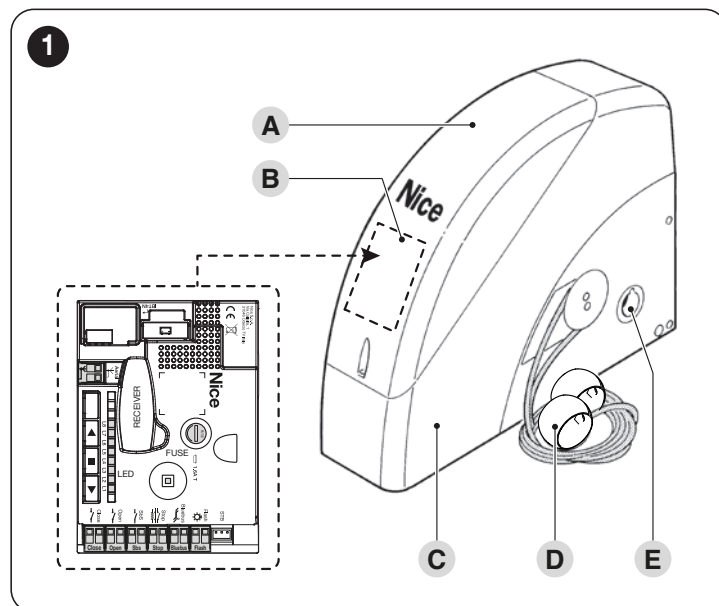

- A** Cover
- B** Electronic control and command unit
- C** Gearmotor body
- D** Locking/unlocking system
- E** Transmission shaft housing

3 INSTALLATION

3.1 PRE-INSTALLATION CHECKS



The installation must be carried out by qualified personnel in compliance with the current legislation, standards and regulations, and with the instructions provided in this manual.

Before proceeding with the product's installation, it is necessary to:

- check the integrity of the supply
- check that all the materials are in good working order and suited to the intended use
- make sure that the structure of the door is suitable for being automated
- make sure that the characteristics of the door fall within the operating limits specified in the "**Product usage limits**" paragraph (page 4)
- verify that there are no points of greater friction during the opening and closing movements along the entire door path
- verify that the area where the gearmotor is installed allows for unlocking the latter and manoeuvring easily and safely
- Verify that the mounting points of the various devices are protected against impacts and that the mounting surfaces are sufficiently sturdy
- Components must never be immersed in water or other liquids
- Keep the product away from heat sources and open flames and acid, saline or potentially explosive atmospheres; these may damage the product and cause malfunctions or dangerous situations
- Connect the control unit to an electricity supply line equipped with a safety earthing system
- Mount a device on the electric power line that completely disconnects the automation from the grid. The disconnection device must have contacts with a sufficient gap to ensure complete disconnection, under the Category III overvoltage conditions, in accordance with the installation instructions. Should it be necessary, this device guarantees fast and safe disconnection from the power supply; it must therefore be positioned in view of the automation. If placed in a non-visible location, it must have a system that blocks any accidental or unauthorised reconnection of the power supply, in order to prevent dangerous situations. The disconnection device is not supplied with the product.

3.2 PRODUCT USAGE LIMITS

The data relative to the product's performances is included in the "**TECHNICAL SPECIFICATIONS**" chapter (page 30) and is the only data that allows for properly assessing whether the product is suitable for its intended use.

Check the application limits of **SO2000** and of the accessories to be installed, assessing whether their characteristics are capable of meeting the requirements of the environment and the limitations specified below:

- the door dimensions must be below 20 m²
- the drive shaft must be compatible with the **SO2000** output and the relative keys supplied with the package
- the wall-mounting bracket must be sufficiently long.

Table 1

SO2000 - LIMITATIONS OF USE IN RELATION TO THE TYPE OF DOOR		
Type of door	Operating limits (m)	
Door	Max height 5	Max width 4

The measurements shown in "**Table 1**" are purely indicative and are only needed for making a rough estimate. The actual suitability of **SO2000** for automating a specific door depends on the degree of leaf balancing, guide friction and other aspects, including occasional events such as wind pressure or the presence of frost, which could obstruct the leaf's movement. To determine the actual conditions, the force required to move the leaf throughout its path must be measured, to ensure that this value does not exceed the "rated torque" specified in the "**TECHNICAL SPECIFICATIONS**" chapter; moreover, to calculate the number of cycles/hour and consecutive cycles, it is important to consider the data shown in "**Table 2**".

Table 2

SO2000 - LIMITS RELATING TO THE FORCE REQUIRED TO MOVE THE DOOR LEAF	
Force required to move the leaf (N)	Maximum no. of cycles/hour Maximum no. of consecutive cycles
Up to 120	20
	35
120 ÷ 180	18
	33
180 ÷ 220	15
	30



The control unit is equipped with a manoeuvre limiting device that prevents possible overheating; it is based on the motor load and duration of the cycles, and intervenes when the maximum limit is exceeded.

3.2.1 PRODUCT DURABILITY

The product's durability is its average economic life value and is strongly influenced by the degree of severity of the manoeuvres: in other words, the sum of all factors that contribute to product wear.

To estimate the durability of your automated device, proceed as follows:

1. add the values of the items in "**Table 3**" relative to the system's conditions
2. in the graph shown in "**Figure 2**", from the value obtained above, trace a vertical line until it intersects the curve; from this point trace a horizontal line until it intersects the line of the "manoeuvre cycles". The value obtained is the estimated lifetime of your product.

The durability values shown in the graph can only be obtained if the maintenance schedule is strictly observed – see the "**PRODUCT MAINTENANCE**" chapter. The durability is estimated on the basis of the design calculations and the results of tests effected on prototypes. Being an estimate, therefore, it offers no explicit guarantee of the product's actual useful life.

Example of durability calculation: automation of a door weighing 130 kg

"**Table 3**" shows the "severity indices" for this type of installation: 30% ("Weight of the door"), 20% ("Force required to move the door") and 10% ("Ambient temperature above 40°C or below 0°C or humidity above 80%"). These indicators must be added together to obtain the overall severity index, which in this case is 60%. With the value identified (60%), look at the horizontal axis of the graph ("severity index") and identify the value corresponding to the number of "manoeuvre cycles" that the product can perform throughout its lifetime – roughly 18,000 cycles.

Table 3

PRODUCT DURABILITY		Severity index
Weight of the door	< 100 kg	20%
	100 - 180 kg	30%
	180 - 230 kg	40%
	> 230 kg	60%
Force required to move the door	< 160 kg	10%
	160 - 240 kg	20%
	240 - 290 kg	40%
Ambient temperature greater than 40°C or below 0°C, or humidity greater than 80%		10%
Presence of dust, sand or salinity		15%
Manoeuvre interrupted by photocell		10%
Manoeuvre interrupted by Stop		20%
Speed greater than "L4 fast"		15%

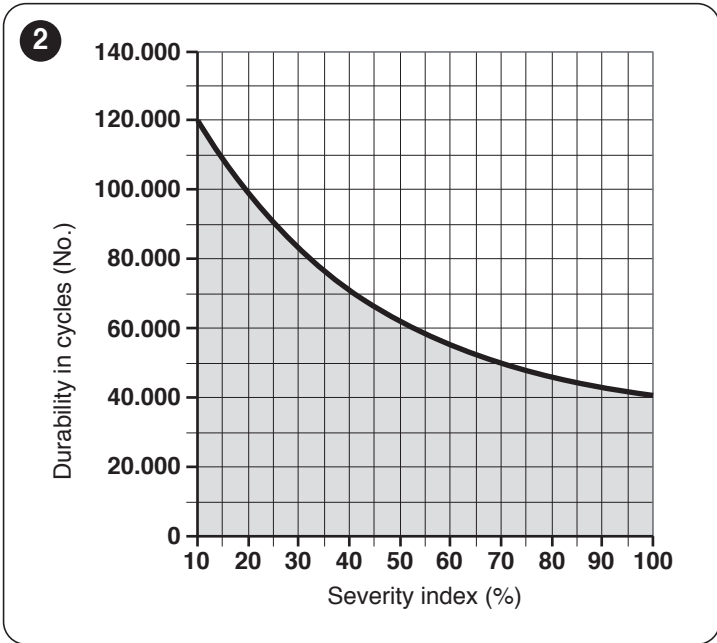

3.3 PRODUCT IDENTIFICATION AND OVERALL DIMENSIONS

The overall dimensions and the label (A), which allows for identifying the product, are shown in "Figure 3".

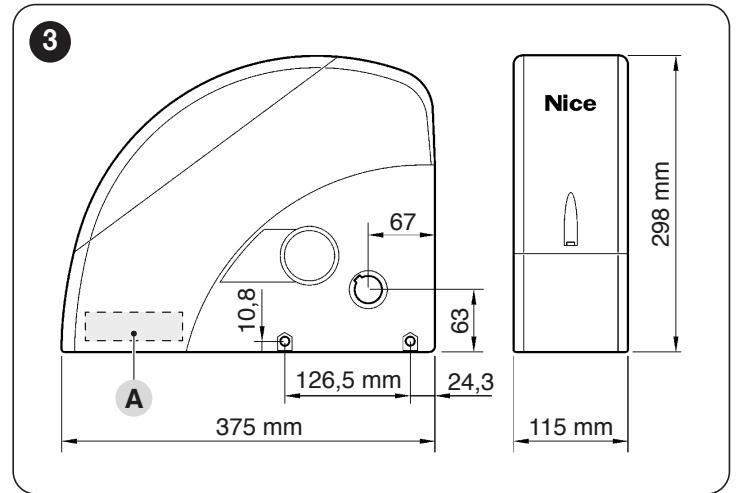

3.4 RECEIPT OF THE PRODUCT

All the components contained in the product's packaging are illustrated and listed below.

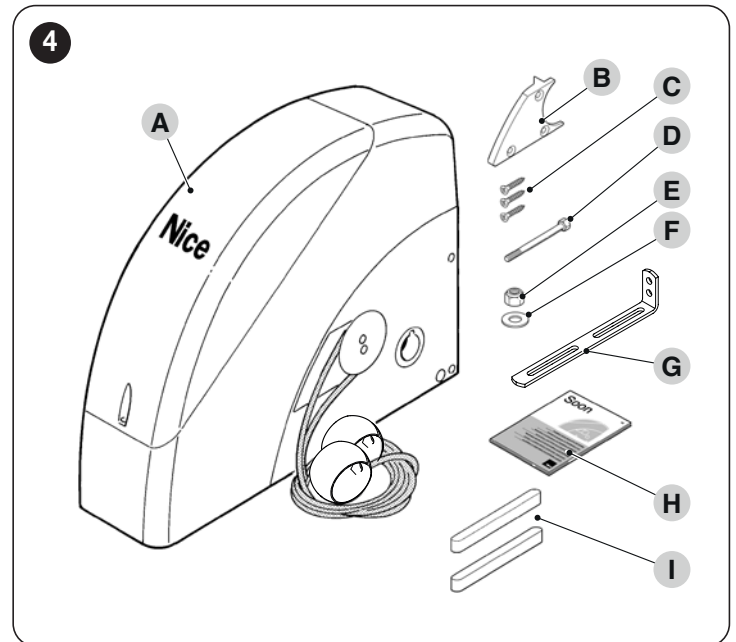

- A** Gearmotor
- B** Release mechanism
- C** 3 black self-tapping screws
- D** M8x130 screw
- E** M8 locknut
- F** D8 washer
- G** Mounting bracket
- H** User manual
- I** 2 keys

3.5 PRE-INSTALLATION WORKS

The figure shows an example of an automation system, constructed using **Nice** components.

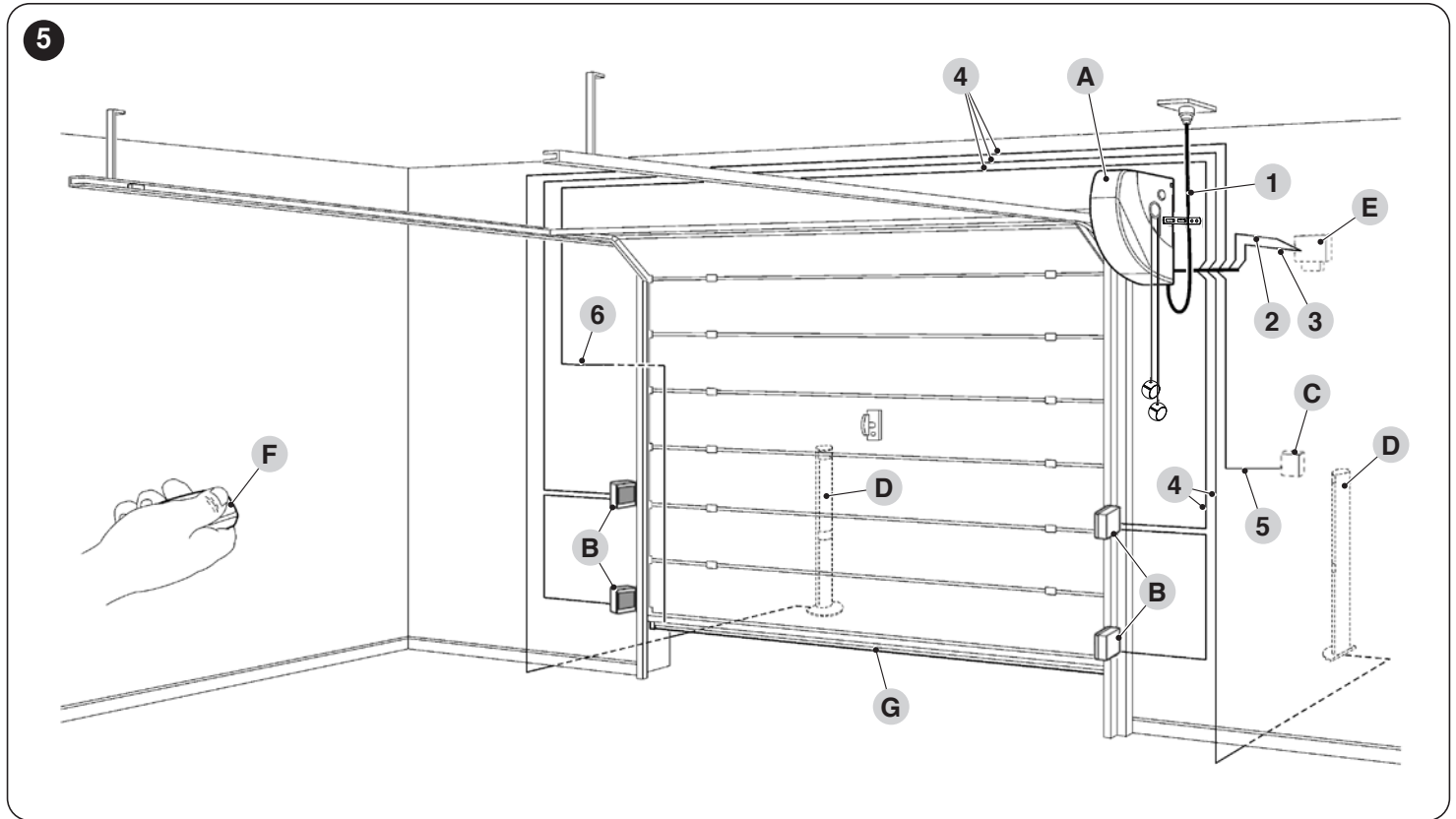

- A** Gearmotor
- B** Photocells
- C** Key selector
- D** Photocells on column
- E** Warning light with incorporated antenna
- F** Transmitter
- G** Main edge

These above-mentioned components are positioned according to a typical standard layout. Using the layout in **“Figure 5”** as a reference, define the approximate position in which each component of the system will be installed.

Table 4

TECHNICAL SPECIFICATIONS OF ELECTRICAL CABLES	
Identification no.	Cable characteristics
1	GEARMOTOR POWER SUPPLY cable 1 cable 3 x 1.5 mm ² Maximum length 30 m [note 1]
2	WARNING LIGHT cable 1 cable 2 x 1 mm ² Maximum length 20 m
3	ANTENNA cable 1 x RG58-type shielded cable Maximum length 20 m; recommended < 5 m
4	PHOTOCELL cable 1 cable 2 x 0.5 mm ² Maximum length 30 m [note 2]
5	KEY SELECTOR cable 2 cables 2 x 0.5 mm ² [note 3] Maximum length 50 m
6	MAIN EDGE cable 1 cable 2 x 0.5 mm ² Maximum length 20 m

Note 1 If the power supply cable is longer than 30 m, a cable with larger cross-sectional area (3 x 2.5 mm²) must be used and a safety earthing system must be installed near the automation.

Note 2 If the BlueBus cable is longer than 30 m, up to maximum 50 m, it is necessary to use a cable with a greater cross-sectional area (2 x 1 mm²).

Note 3 These two cables can be replaced by a single 4 x 0.5 mm² cable.

! Before proceeding with the installation, prepare the required electrical cables by referring to **“Figure 5”** and to that stated in the **“TECHNICAL SPECIFICATIONS”** chapter.

! The cables used must be suited to the type of environment of the installation site.

! When laying the pipes for routing the electrical cables, take into account that any water deposits in the junction boxes may cause the connection pipes to form condensate inside the control unit, thus damaging the electronic circuits.

3.6 INSTALLING THE GEARMOTOR

! Incorrect installation may cause serious physical injury to the person working on the system or to its future users.

Before starting to assemble the automation, complete the preliminary checks described in the “Pre-installation checks” paragraph (page 4) and the “Product usage limits” paragraph (page 4).

! The automation must be installed **EXCLUSIVELY WITH THE DOOR CLOSED**.

To install **SO2000**:

1. insert the output shaft (A) into the transmission shaft (B) of the door, coupling them with the aid of the key (C) provided

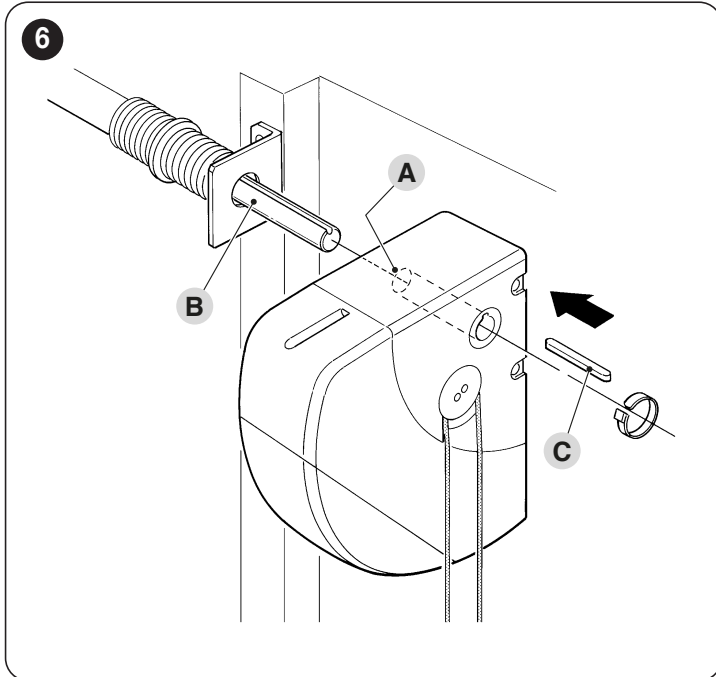

2. fasten the bracket (E) to the gearmotor (D) using the screw, nut and washer provided

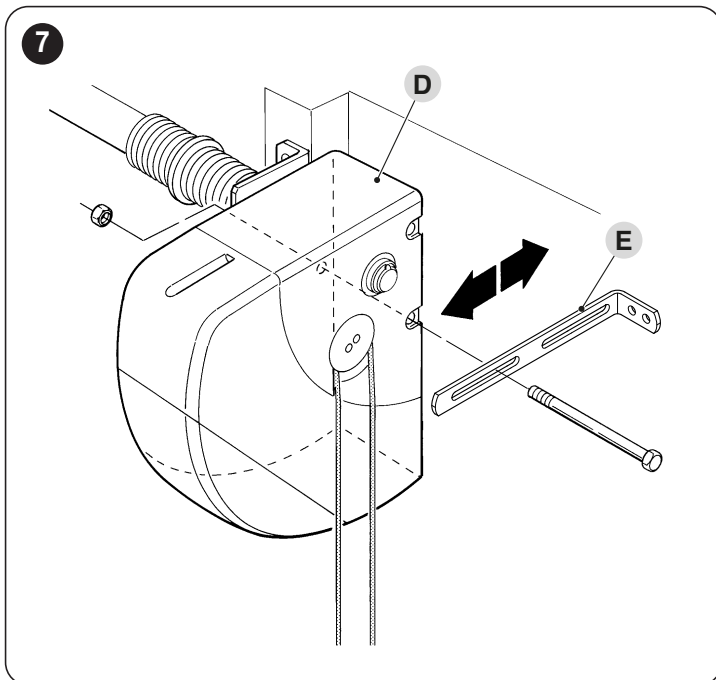

3. fasten the bracket (E) to the wall using wall plugs (not supplied) suited to the wall's material

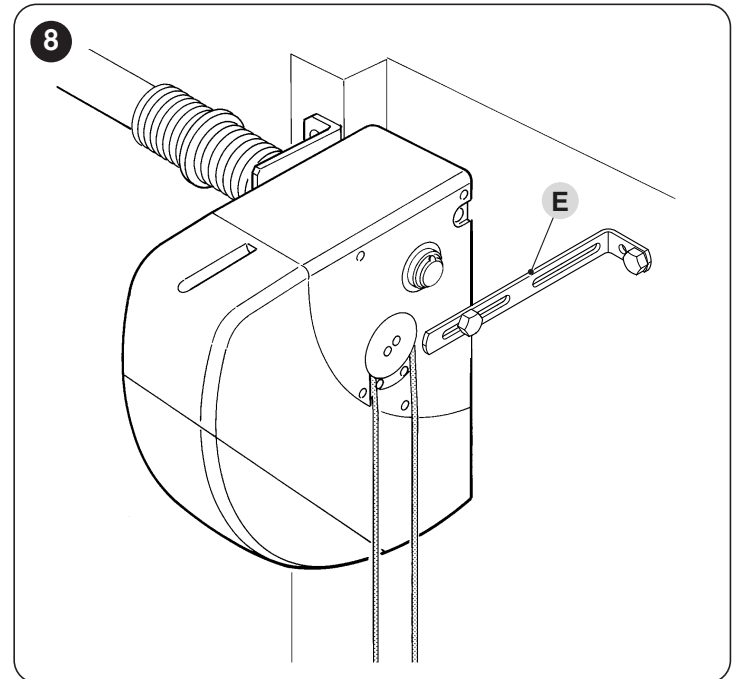

4. **SO2000** can be installed in the horizontal position using the release mechanism (F), supplied with the kit, which must be fastened with the three screws in the position shown, while making sure that the unlocking cables (G) are fed through.

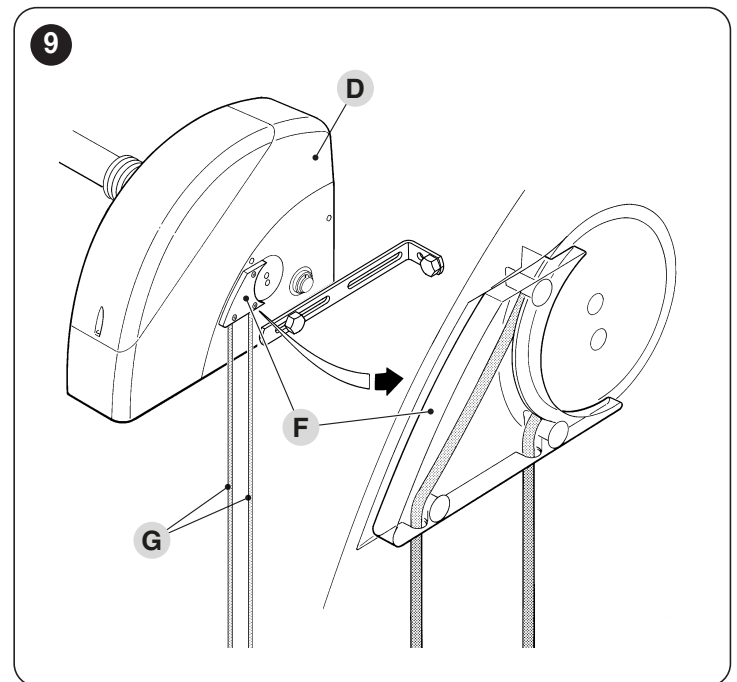

3.7 MANUALLY UNLOCKING AND LOCKING THE GEARMOTOR

The gearmotor is equipped with a mechanical unlocking device that can be used to open and close the door manually.

These manual operations should only be performed in case of a power outage, malfunctions or during the installation phases.

To unlock the device:

1. pull the releasing cord (A)
2. the door can now be moved manually to the desired position.

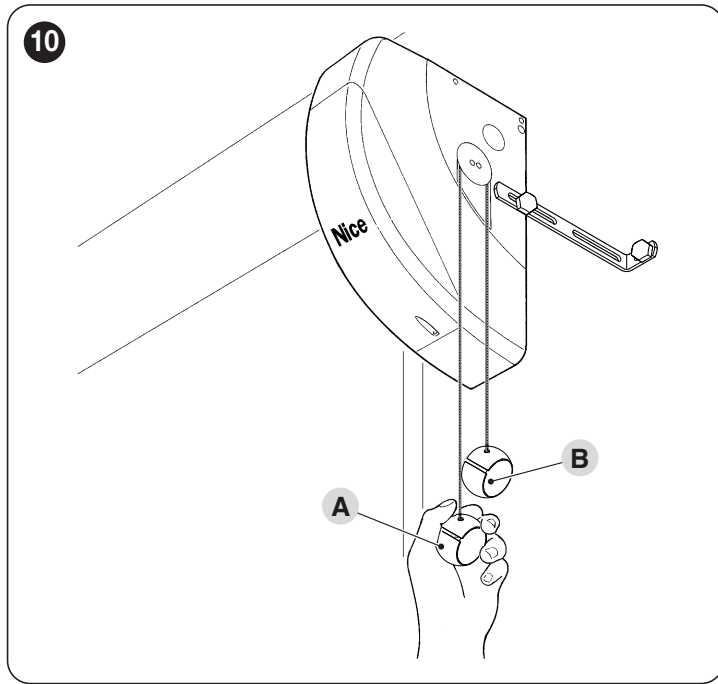

To lock the mechanism, pull the ball (B).

4 ELECTRICAL CONNECTIONS

4.1 PRELIMINARY CHECKS



All electrical connections must be made with the system disconnected from the mains electricity and with the emergency power supply (if present in the automation) disconnected.



The connection operations must only be carried out by qualified personnel.

To make the electrical connections:

1. take out the screw and remove the protective cover (A) by lifting it up

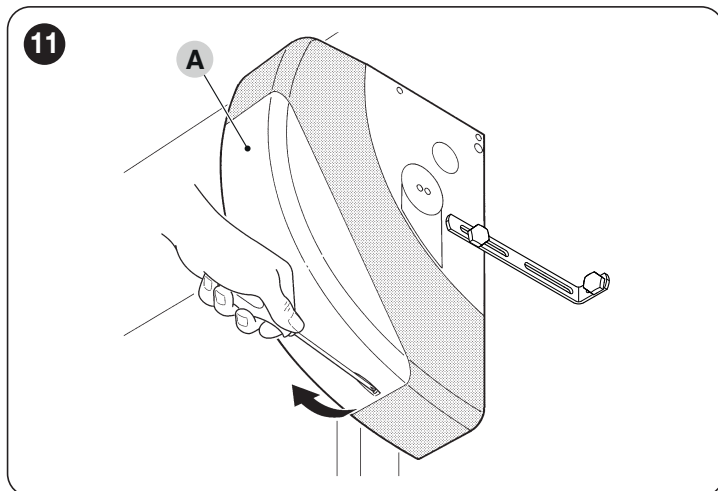

2. insert all the connecting cables into the various devices, leaving them 20–30 cm longer than necessary. Refer to "Table 4" for the type of cables and to "Figure 5" for the connections.
3. use a clamp to hold together all the cables entering the gearmotor then place the clamp slightly below the cable entry hole
4. connect the power cable (B) to the relevant terminal as shown in the figure, then use another clamp to fasten the cable onto the first cable ring

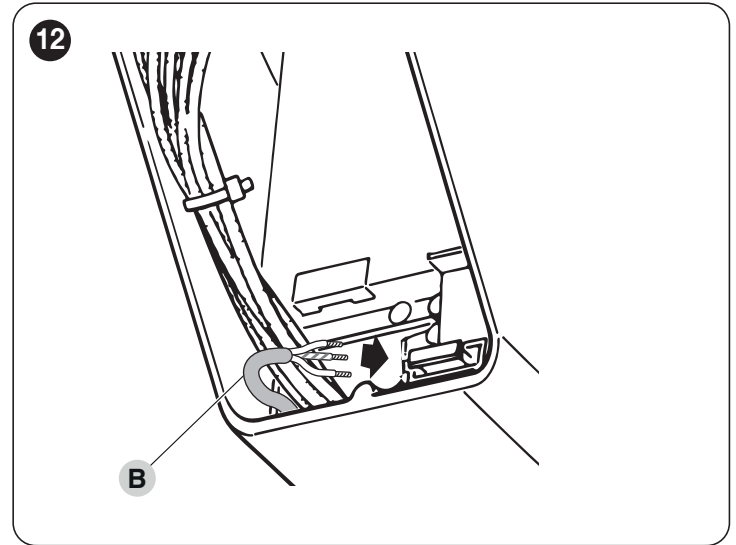

5. connect the other cables according to the diagram shown in "Figures 13" and "14". For greater convenience, the terminals are removable.
6. after making the connections, lock the cables in the appropriate rings. The excess part of the antenna cable must be secured to the other cables.

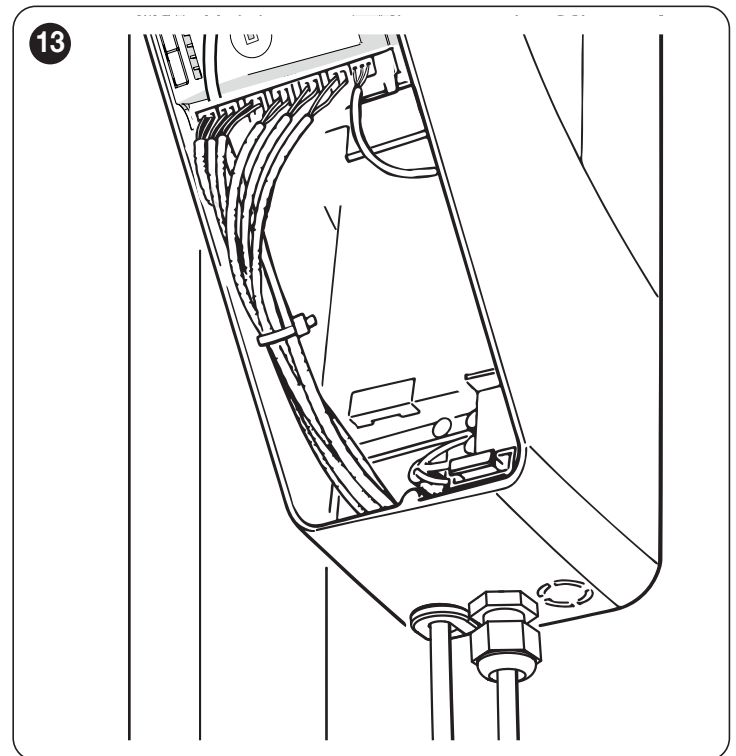

4.2 WIRING DIAGRAM AND DESCRIPTION OF CONNECTIONS

4.2.1 WIRING DIAGRAM

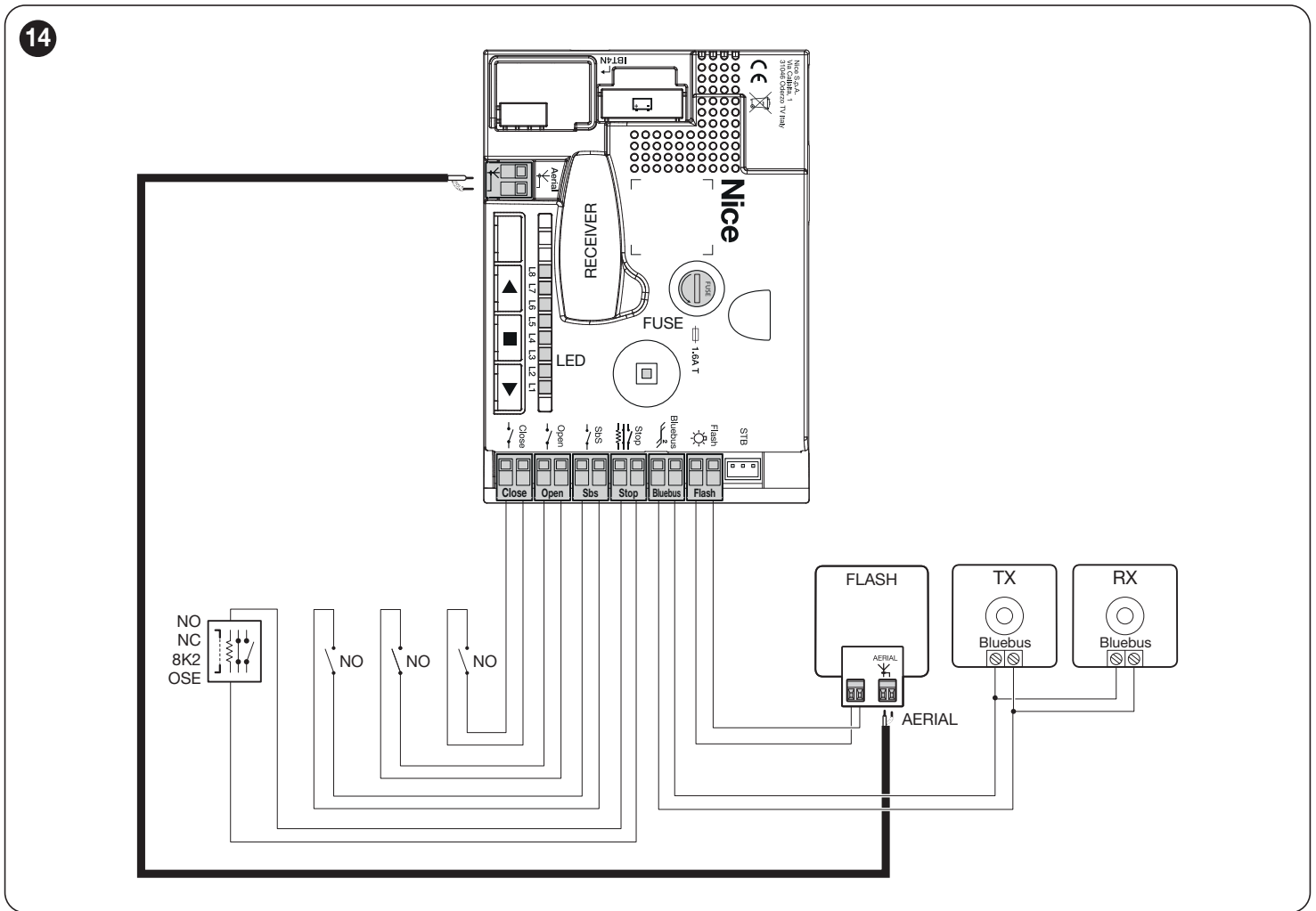

4.2.2 DESCRIPTION OF CONNECTIONS

Table 5

ELECTRICAL CONNECTIONS	
Terminals	Description
FLASH	This output is programmable (refer to the “ PROGRAMMING ” chapter) to connect one of the following devices: Warning light , “ Door open indicator ” output, Suction cup [note 1] , Electric latch [note 1] , Electric lock [note 1] .
	If programmed as “ warning light ”, on the “FLASH” output it is possible to connect a “LUCYB” warning light or similar with a single 12 V maximum 21 W car-type lamp. During the manoeuvre, check that the warning light flashes at intervals of 0.5 seconds on and 0.5 seconds off.
	If programmed as “ door open indicator ”, on the “FLASH” output it is possible to connect a 24 V max 5 W indicator light to signal the door open status. It can also be programmed for other functions (refer to the “ PROGRAMMING ” chapter).
	If programmed as “ suction cup ”, on the “FLASH” output it is possible to connect a 24 V max 10 W suction cup (versions with electromagnet only, without electronic devices). When the door is closed, the suction cup is activated to lock the door in place. During the opening and closing manoeuvre, it is deactivated.
	If programmed as “ electric latch ”, on the “FLASH” it is possible to connect a 24 V max 10 W electric device with latch (versions with electromagnet only, without electronic devices). During the opening manoeuvre, the electric latch is activated and remains active to free the door and perform the manoeuvre. During the closing manoeuvre, ensure that the electric latch re-engages mechanically.
	If programmed as “ electric lock ”, on the “FLASH” output it is possible to connect a 24 V max 10 W electric lock with latch (versions with electromagnet only, without electronic devices). During the opening manoeuvre, the electric lock is activated for a brief interval to free the door and perform the manoeuvre. During the closing manoeuvre, ensure that the electric lock re-engages mechanically.

Note 1 Only devices containing the electromagnet only can be connected.

ELECTRICAL CONNECTIONS	
Terminals	Description
BLUEBUS	This terminal can be used to connect compatible devices, which are all connected in parallel with only two wires carrying both the electric power and communication signals. For further information on the BlueBUS, refer to the “Addressing of devices connected with the BlueBUS system” paragraph.
STOP	Input for the devices that block or, if necessary, stop the manoeuvre under way. With suitable arrangements, “Normally Closed” or “Normally Open” contacts, or fixed resistor or optical devices can be connected to the input. For further information on the STOP function, refer to the “Modifying the STOP input configuration” paragraph.
Sbs	Input for devices that control the movement in Step-by-Step mode; it is possible to connect “Normally Open” contacts.
OPEN	Input for devices that control the opening movement only; it is possible to connect “Normally Open” contacts.
CLOSE	Input for devices that control the closing movement only; it is possible to connect “Normally Open” contacts.
ANTENNA	Antenna connection input for radio receiver; the antenna is incorporated in the warning light; alternatively, an external antenna can be used.
STB	Connector for connecting the Standby board.

4.3 ADDRESSING OF DEVICES CONNECTED WITH THE BLUEBUS SYSTEM

By means of addressing using special jumpers, the “BlueBUS” system enables the user to make the control unit recognise the photocells and assign the correct detection function.

The addressing operation must be done on both the TX and RX photocells (setting the jumpers in the same way), while making sure there are no other pairs of photocells with the same address.

In systems for automated overhead doors, the photocells can be connected as shown in the figure below.

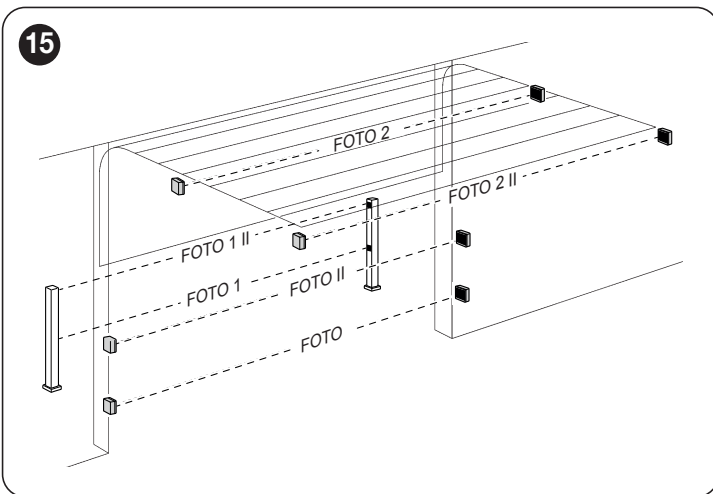

Hand icon: At the end of the installation procedure, or after photocells or other devices have been removed, it is necessary to complete the learning procedure (see the **“Device learning”** paragraph).

Table 6

PHOTOCELL ADDRESSES	
Photocell	Position of the jumpers
FOTO (PHOTO) External photocell h = 50 activated during the closing phase (stops and reverses the gate’s movement)	
FOTO II (PHOTO II) External photocell h = 100 activated during the closing phase (stops and reverses the gate’s movement)	
FOTO 1 (PHOTO 1) Internal photocell h = 50 activated during the closing and opening phases (stops and reverses the door’s movement)	
FOTO 1 II (PHOTO 1 II) Internal photocell h = 100 activated during the closing and opening phases (stops and reverses the door’s movement)	
FOTO 2 (PHOTO 2) External photocell activated during the opening phase	
FOTO 2 II (PHOTO 2 II) Internal photocell activated during the opening phase	
FOTO 3 (PHOTO 3) Single photocell covering the entire automation	
FA1 Photocell for opening command (cut jumper A on the back of the TX and RX boards)	
FA2 Photocell for opening command (cut jumper A on the back of the TX and RX boards)	

4.3.1 FT210B PHOTOSENSOR

The FT210B photosensor combines in a single device a force limiting system (type C, in accordance with the EN12453 standard) and a presence sensor that detects obstacles on the line of sight between the TX transmitter and RX receiver (type D, in accordance with the EN12453 standard). In the FT210B photosensor, the signals regarding the status of the sensitive edge are sent through the photocell range, integrating the 2 systems in a single device. The transmitting element located on the moving leaf is battery-powered, which eliminates visually unpleasant connection systems; special circuits reduce battery consumption, ensuring up to 15 years' life (see estimation details in the product's instructions).

A single FT210B device combined with a sensitive edge (TCB65, for example) allows for attaining the level of safety of the "primary edge" required by the EN12453 standard for all "types of use" and "types of activation".

The FT210B photosensor combined with the "resistive" sensitive edges (8.2 kΩ) is safe against faults (category 3 pursuant to the EN 13849-1 standard). It is equipped with a special anti-collision circuit to prevent interference with other detectors, even not synchronised, and allows for adding other photocells; for example, in case of transit of heavy vehicles, where a second photocell is normally positioned 1 m above the ground.

 **Consult the FT210B instruction manual for further information on the connection and addressing methods.**

5 FINAL CHECKS AND START-UP

It is advisable to position the leaf approximately halfway along its path before starting the automation check and start-up phases, so that the leaf is free to open and close.

5.1 POWER SUPPLY CONNECTION

 **The power supply connections must only be made by qualified and experienced personnel possessing the necessary requirements and in full conformity to the laws, regulations and standards in force.**

As soon as the product is powered, a few simple checks should be carried out:

1. check that the BlueBus LED flashes regularly with one flash per second.
2. make sure that the LEDs on the photocells (both the TX and RX) also flash; the type of flashing is irrelevant, since it depends on other factors.
3. check that the warning light connected to the FLASH output is off.
4. check that the courtesy light is off.

If the above conditions are not satisfied, immediately switch off the power supply to the control unit and carefully check the electrical connections. Further useful information on fault search and diagnosis is included in the "Troubleshooting" paragraph (page 21).

5.2 DEVICE LEARNING

Once the power supply has been connected, the control unit must recognise the devices connected to the "BlueBUS" and "STOP" inputs. Prior to this phase, LEDs "L1" and "L2" will flash to signal that the device learning procedure must be performed.



The learning phase must be carried out even if no device is connected to the control unit.

To do this:

1. simultaneously press and hold the ▲ and ■ buttons
2. release the buttons when LEDs "L1" and "L2" start flashing quickly (after roughly 3 seconds)
3. wait a few seconds until the control unit has completed the device learning phase
4. once this phase terminates, the "Stop" LED must be lit and LEDs "L1" and "L2" must switch off (LEDs "L3" and "L4" could start flashing).

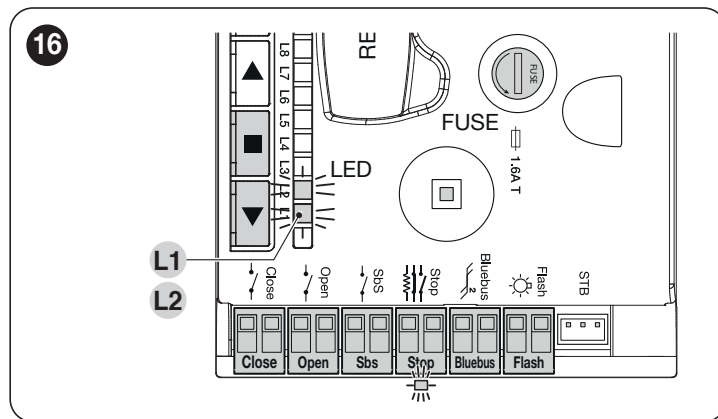

The self-learning phase of the connected devices can be repeated at any time also after the installation, for example whenever a device must be added.

5.3 LEARNING OF THE DOOR OPENING AND CLOSING POSITIONS

Once the devices have been learned, the control unit must recognise the door opening and closing positions, in addition to a few optional positions. There are 6 positions in total:

Before this phase, LEDs "L3" and "L4" flash ("Figure 17") to signal that the positions must be learned.

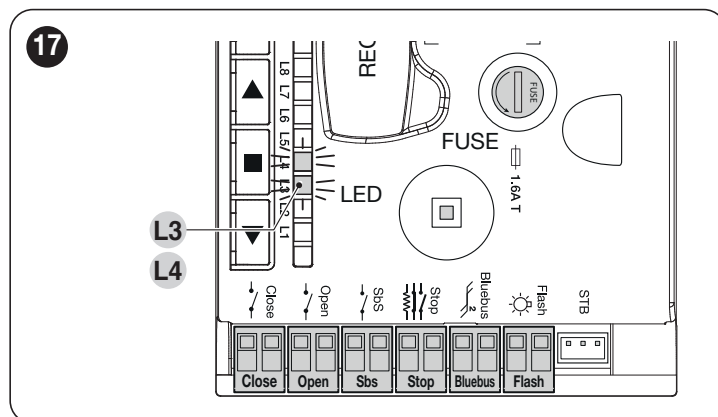

The position memorisation procedures are described below.

Two procedures are available:

- **FULL**: enables the user to manually set multiple positions (FCA-opening limit switch, RA-opening slowdown, RI-intermediate slowdown, AP-partial opening, etc.)
- **REDUCED**: allows for setting only the opening and closing limit switches (respectively FCA and FCC; the other positions will be calculated autonomously by the control unit). If necessary, they can be modified at a later stage through the full procedure.

Table 7

PROGRAMMING POSITIONS		
Position	LED	Description
A1	L1	Maximum desired opening position. When the door reaches this position it stops.
RA1	L2	Slowdown start position during opening manoeuvre. When the door reaches this position, the motor slows down to the minimum speed.
RINT	L4	Intermediate slowdown position during closing manoeuvre. When this point is programmed, the door starts to slow down roughly 50 cm before the point so that it passes the intermediate slowdown position at minimum speed. On passing the intermediate slowdown position, the motor returns to the set speed.
AP	L5	Partial opening position. This is the position at which the door stops after receiving a partial opening command.
RA0	L7	Slowdown start position during closing manoeuvre. When the door reaches this position, the motor slows down to the minimum speed.
A0	L8	Maximum closing position. When the door reaches this position it stops.



The automation can only be moved between the 5% and 95% values of the nominal range. If the automation's position falls out of this range, the control unit will signal an overrun error (refer to the control unit signals chapter); it is necessary to manually turn the motor axis or impart any manoeuvre command to bring the automation back to a valid position. If this is not done, the automation cannot be moved in any way.

FULL PROCEDURE

1. Press the and buttons for 3 seconds to enter the position memorisation mode

Position A1 programming, LED "L1" flashes:

2. use the and buttons to move the door to the maximum opening position
3. press the button for 2 seconds to confirm position "A1". LED "L1" will remain lit

Position RA1 programming, LED "L2" flashes:

4. if the opening slowdown position does not have to be programmed, press the button twice rapidly to skip to the next programming; LED "L2" will remain off. Otherwise, proceed with the sequence
5. use the and buttons to move the door to the opening slowdown position
6. press the button for 2 seconds to confirm position "RA1". LED "L2" will remain lit

Position RINT programming, LED "L4" flashes:

7. If the intermediate slowdown position does not have to be programmed, press the button twice rapidly to skip to the next programming; LED "L4" will remain off. Otherwise, proceed with the sequence
8. use the and buttons to move the door to the intermediate slowdown position
9. press the button for 2 seconds to confirm position "RINT". LED "L4" will remain lit

Position RAP programming, LED "L5" flashes:

10. if the partial opening position does not have to be programmed, press the button twice rapidly to skip to the next programming; LED "L5" will remain off. Otherwise, proceed with the sequence
11. use the and buttons to move the door to the partial opening position
12. press the button for 2 seconds to confirm position "RAP". LED "L5" will remain lit

Position RA0 programming, LED "L7" flashes:

13. if the closing slowdown position does not have to be programmed, press the button twice rapidly to skip to the next programming; LED "L7" will remain off. Otherwise, proceed with the sequence
14. use the and buttons to move the door to the closing slowdown position
15. press the button for 2 seconds to confirm position "RA0". LED "L7" will remain lit

Position A0 programming, LED "L8" flashes:

16. use the and buttons to move the door to the maximum closing position
17. press the button for 2 seconds to confirm position "A0". LED "L8" will remain lit
18. when the button is released, all the LEDs will switch off
19. the courtesy light will start flashing once every second (1 Hz) to signal the need to run the MANDATORY "Automatic Force Search" procedure. During the "Automatic Force Search" procedure, check that there are no assembly and adjustment defects, or other anomalies, for example points of excessive friction
20. impart a movement command (for example: through the "SbS", "OPEN" inputs) to start the "Automatic Force Search" procedure: 3 complete cycles will be performed. If the above-mentioned procedure is interrupted, it can be restarted by selecting the "SbS", "Open", "Close" commands.

REDUCED PROCEDURE

1. Press the and buttons for 3 seconds to enter the position memorisation mode

Position A1 programming, LED "L1" flashes:

2. use the and buttons to move the door to the maximum opening position
3. press the button for 5 seconds to confirm position "A1". LED "L1" will remain lit
4. Release the button

Position A0 programming, LED "L8" flashes:

5. use the and buttons to move the door to the maximum closing position
6. press the button for 2 seconds to confirm position "A0". LED "L8" will remain lit
7. when the button is released, all the LEDs will switch off

8. the courtesy light will start flashing once every second (1 Hz) to signal the need to run the MANDATORY “Automatic Force Search” procedure. During the “Automatic Force Search” procedure, check that there are no assembly and adjustment defects, or other anomalies, for example points of excessive friction
9. impart a movement command (for example: through the “Sbs”, “OPEN” inputs) to start the “Automatic Force Search” procedure: 3 complete cycles will be performed. If the above-mentioned procedure is interrupted, it can be restarted by selecting the “Sbs”, “Open”, “Close” commands.

During these manoeuvres, the control unit memorises the force required for the opening and closing movements.

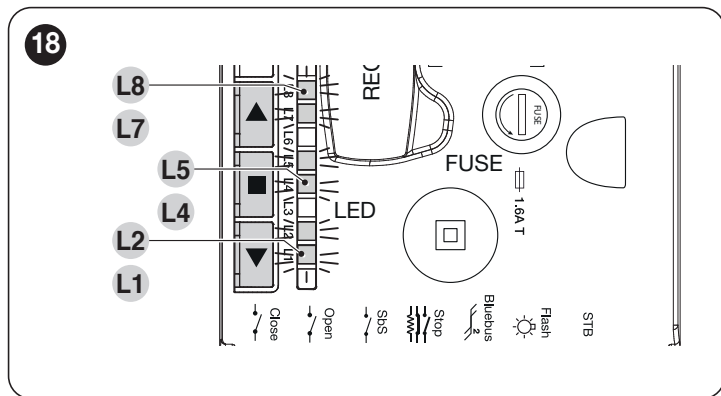

The position learning procedure can be redone at any time, even after installation; simply repeat it from the beginning. If only a single position must be modified, repeat the reduced procedure only.



It is important that the “Automatic Force Search” procedure is not interrupted, e.g. by a STOP command. If the “positions”, “motor opening speed”, “motor closing speed” and “motor rotation direction” parameters are modified, the “Automatic Force Search” procedure will be automatically re-proposed by the control unit. The procedure must terminate correctly and autonomously, that is, without any interruptions: the procedure will remain pending even after a blackout.

5.4 CHECKING THE DOOR MOVEMENT

Once the leaf length has been learned, it is advisable to carry out a few manoeuvres in order to verify that the door moves properly.

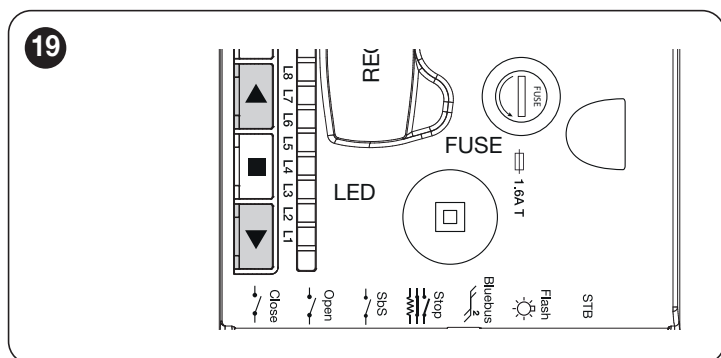

To do this:

1. press the ▲ button to command an “Open” manoeuvre; check that the door opens properly without any speed variations; only when the leaf reaches the “RA1” position, it must reach the minimum speed and stop at the “A1” maximum opening position
2. press the ▼ button to command a “Close” manoeuvre; check that the door closes properly without any speed variations; only when the leaf reaches the “RA0” position, it must reach the minimum speed and stop at the “A0” maximum closing position
3. during the manoeuvre, check that the warning light flashes at intervals of 0.5 seconds on and 0.5 seconds off
4. open and close the gate several times to make sure that there are no points of excessive friction and that there are no defects in the assembly or adjustments
5. check that the gearmotor is fastened in a solid, stable and suitably resistant manner even during sudden door acceleration or slow-down movements.

5.5 CONNECTING OTHER DEVICES

If the user needs to power external devices, such as a proximity reader for transponder cards or the light of the key selector switch, power can be tapped as shown in the figure.

The power supply voltage is 24V \pm -30% ÷ +50% with a maximum available current of 100mA.

In calculating the consumption in Standby Mode, the energy consumption of the accessories has not been considered. Check the respective instructions for the consumption of these accessories.

WARNING: in Standby mode the power supply drops to 21V \pm +/-10% with an available power of 2W.

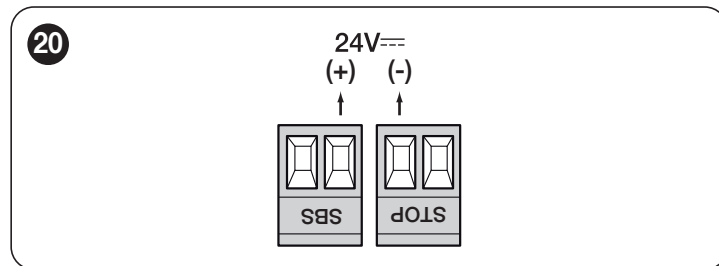

6 TESTING AND COMMISSIONING

These are the most important phases of the automation's construction, as they ensure maximum safety of the system. The test can also be used to periodically verify the devices making up the automation.



Testing and commissioning of the automation must be performed by skilled and qualified personnel, who are responsible for the tests required to verify the solutions adopted according to the risks present, and for ensuring that all legal provisions, standards and regulations are met, in particular all the requirements of the EN 12453 standard, which defines the test methods for checking door automations.

The additional devices must undergo specific testing, both in terms of their functions and their proper interaction with the control unit. Refer to the instruction manuals of the individual devices.

6.1 TESTING



The standby function is active by default. The control unit enters Standby Mode by turning off some circuits and reducing consumption after 10 minutes from switching on if the board is not configured with the quotas and after 5 minutes if it is configured.

To run the test:

1. verify that all the instructions stated in the "**GENERAL SAFETY WARNINGS AND PRECAUTIONS**" chapter (page 2) have been strictly observed
2. unlock the gearmotor as indicated in the "**Manually unlocking and locking the gearmotor**" paragraph (page 8)
3. make sure that the gate can be moved manually during both the opening and closing phases with a force not exceeding 225N (roughly 23 kg)
4. lock the gearmotor
5. using the control devices (selector, radio transmitter, etc.), test the door opening, closing and stoppage phases, ensuring that the movement matches the specifications. Run several tests to check that the door moves smoothly and check for any defects in the assembly or adjustment and any possible points of friction
6. To check the operation of the photocells and ensure that there is no interference with other devices, pass a cylinder (5 cm diameter, 30 cm length) on the optical axis, first near the "**TX**" photocell then near "**RX**" photocell and, lastly, at the mid-point between the two and verify that in all these cases the device is triggered, switching from the active to the alarm status and vice-versa; make sure that it triggers the intended action in the control unit; for example, that it triggers the reversal of movement during the closing manoeuvre.
7. check, one-by-one, that all safety devices mounted on the system (photocells, sensitive edges, etc.) work properly. Each time a device intervenes, the "**Bluebus**" LED on the control unit will emit two faster flashes to confirm the recognition
8. if potentially dangerous situations due to the movement of the leaves have been prevented by limiting the impact force, the latter must be measured according to the EN 12445 standard and, if the "motor force" control is used to aid the system in reducing the impact force, it is necessary to test various adjustments to find the one that gives the best results.

6.2 COMMISSIONING



Commissioning can only be performed after all testing phases have been successfully completed.



Before commissioning the automation, ensure that the owner is properly informed of all residual risks and hazards.



The gate cannot be commissioned partially or under "temporary" conditions.

To commission the automation:

1. compile the automation's technical file, which must include the following documents: overall drawing of the automation, wiring diagram, risk assessment and relative solutions adopted, the manufacturer's declaration of conformity for all devices used and the declaration of conformity compiled by the installer
2. permanently affix a label or plate in the vicinity of the door, indicating the operations for the door unlocking and manual manoeuvres "**Figure 21**"

21

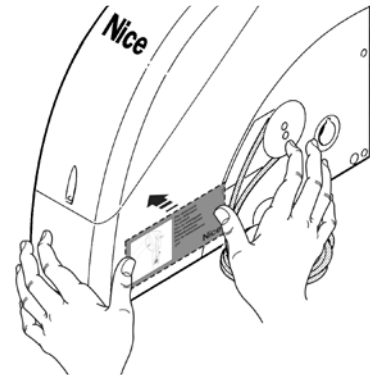

3. permanently affix a label or sign to the door with the following image (minimum height 60 mm) "**Figure 22**"

22

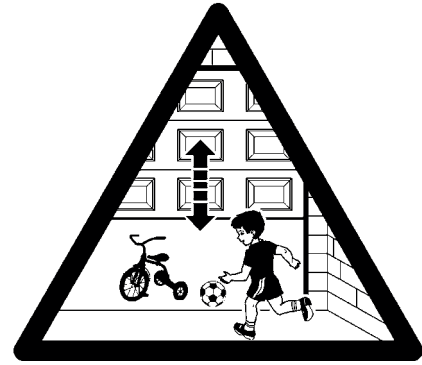

4. affix a label to the door containing at least the following data: type of automation, name and address of manufacturer (person responsible for commissioning), serial number, year of manufacture and the CE mark
5. compile the declaration of conformity of the automation and hand it to the owner of the automation
6. compile the User Manual of the automation and hand it to the owner of the automation
7. compile and provide the owner with the automation's "Maintenance schedule", containing the maintenance instructions for all the automation's devices.



For all the above-mentioned documentation, Nice – through its technical assistance service – provides the following: instruction manuals and guides.

7 PROGRAMMING

There are 3 buttons on the control unit: ▲, ■ and ▼ (“**Figure 23**”) which can be used both to command the control unit during the testing phase and to programme the available functions.

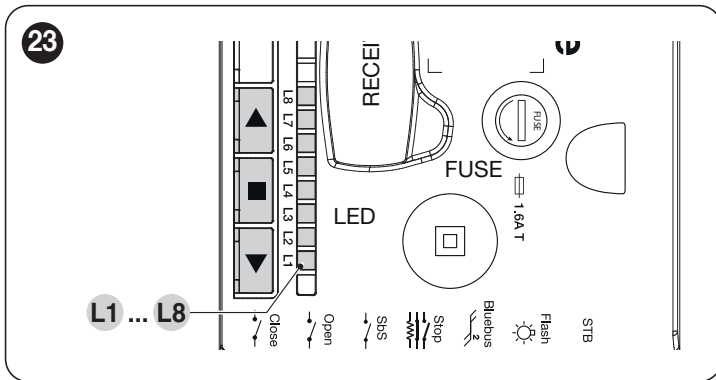

The available programmable functions are grouped into **two levels** and their operating status is signalled by eight LEDs “**L1 ... L8**” located on the control unit (LED lit = function enabled; LED off = function disabled).

7.1 USING THE PROGRAMMING BUTTONS

▲
The button allows for commanding the door opening movement, or shifting the programming point upwards.

■
Button used to stop a manoeuvre.
If pressed for more than 3 seconds, it allows for entering the programming mode.

▼
The button enables the user to close the door or shift the programming point downwards.

Warning! During the manoeuvre, whether opening or closing is irrelevant, all the buttons perform the STOP function and stop the motor’s movement.

7.2 LEVEL 1 PROGRAMMING (ON-OFF)





All the Level 1 functions are factory-set to “OFF” and can be modified at any time. To check the various functions, refer to “Table 8”.

7.2.1 LEVEL 1 PROGRAMMING PROCEDURE



The user has maximum 20 seconds to press the buttons consecutively during the programming procedure. After this time, the procedure terminates automatically and memorises the changes made up to that time.

To perform Level 1 programming:

1. press and hold the  button until LED “L1” starts flashing
2. release the  button when LED “L1” starts flashing
3. press the  or  button to move the flashing LED to the LED associated with the function to be modified
4. press the  button to change the status of the function:
 - short flash = OFF
 - long flash = ON
5. wait 10 seconds (maximum time) to exit the programming mode.



To set other functions to “ON” or “OFF”, while the procedure is running, repeat points 2 and 3 during the phase itself.

Table 8

LEVEL 1 FUNCTIONS (ON-OFF)		
LED	Function	Description
L1	Automatic closing	Function ENABLED: after an opening manoeuvre there is a pause (equal to the set pause time), after which the control unit automatically starts a closing manoeuvre. The pause time is set by default to 30 seconds. Function NOT ENABLED: the system works in “semi-automatic” mode.
L2	Close after photo	Function ENABLED: the behaviour changes depending on whether the “Automatic Closing” function is enabled or not. When “Automatic closing” is not active: The door always reaches the fully open position (even if Photo is disengaged beforehand). When Photo disengages, automatic closing is triggered with a 5-second pause. When “Automatic Closing” is enabled: the opening manoeuvre stops immediately after the photocells have disengaged. After 5 seconds, the gate will start closing automatically. The “Close After Photo” function is always disabled in manoeuvres interrupted by a Stop command. Function DISABLED: the pause time is that which has been programmed or automatic re-closing will not take place if the function is disabled.
L3	Always Close	Function ENABLED: in the event of a blackout, even of short duration, if the control unit detects that the door is open once the electricity is restored, it automatically starts a closing manoeuvre, preceded by a 3-second pre-flashing sequence. Function DISABLED: when the electricity is restored, the gate remains in the same position.
L4	Stand-by	This function allows you to activate/deactivate Standby Mode, significantly reducing consumption. With this function active and connecting external devices as described in “Figure 14”, the product consumption is as stated in the technical characteristics “Power in Standby Mode”. With this function deactivated or with different connections and accessories, consumption will be higher. ACTIVE function: 5 minutes after the end of the maneuver, the control unit turns off the BlueBUS output (and therefore the devices) and all the LEDs except the BlueBUS LED which will flash more slowly. When the control unit receives a command to the SbS terminal, from card keys, radio or via BiDiWiFi, it restores full operation. The function is active by default. Function DISABLED: there will be no reduction in consumption.
L5	Long reversal	This parameter only acts on the “brief inversion” for the intervention of the STOP and the force obstacle detector. Factory configuration: Alt in opening: alt Alt in closing: alt short inversion Detects obstacles opening: alt Detects obstacles closing: short inversion Function ACTIVE: if the intervention is configured as a brief inversion, the total inversion will be performed (up to the maximum opening or closing quota). Function DISABLED: the brief inversion is not modified, but remains the programmed one.
L6	Pre-flashing	Function ENABLED: a 3-second pause can be added between the switching on of the warning light and the start of the manoeuvre, to warn the user in advance of a potentially dangerous situation. Function DISABLED: the signalling of the warning light coincides with the start of the manoeuvre.
L7	Sensitivity	Function ENABLED: allows for considerably increasing the motor’s sensitivity in detecting obstacles. If used to aid impact force detection, the “Speed” and “Motor force” parameters in the Level 2 menu must also be adjusted. Function DISABLED: the motor’s obstacle detection sensitivity is unchanged.
L8	Type of door	Function ENABLED: allows for selecting the type of door to be moved: Light or Heavy. If enabled, the control unit is optimised to move Heavy doors. Function DISABLED: the control unit is optimised to move smaller-size doors.



During normal operation, in other words when no manoeuvre is under way, LEDs “L1 ... L8” are on or off depending on the status of the respective function; for example, “L1” is lit when the “Automatic Closing” function is enabled. During the manoeuvre, LEDs “L1 ... L8” flash to signal the force required to move the door at that time. If “L1” flashes, the force required is low and so forth, until LED “L8” flashes to signal the maximum force. There is no relation between the force level indicated by the LEDs during the movement (which is an absolute value) and the level indicated by the LEDs during the force (which is a relative value) programming phase. See “L5” and “L6” in “Table 9”.

7.3 LEVEL 2 PROGRAMMING (ADJUSTABLE PARAMETERS)

All the Level 2 parameters are factory-set as highlighted in "GREY" in "Table 9" and can be modified at any time. The parameters can be set to a scale of 1 to 8. The check the value corresponding to each LED, refer to "Table 9".

7.3.1 LEVEL 2 PROGRAMMING PROCEDURE



The user has maximum 20 seconds to press the buttons consecutively during the programming procedure. After this time, the procedure terminates automatically and memorises the changes made up to that time.

To perform Level 2 programming:

1. press and hold the button until LED "L1" starts flashing
2. release the button when LED "L1" starts flashing
3. press the or button to move the flashing LED to the "entry LED" associated with the parameter to be modified
4. press and hold the button. With the button pressed:
 - wait roughly 3 seconds, until the LED representing the current level of the parameter to be modified lights up
 - press the or button to shift the LED associated with the parameter's value
5. release the button
6. wait 10 seconds (maximum time) to exit the programming mode.



To set multiple parameters during the procedure's execution, repeat the operations from point 2 to point 4 during the phase itself.

Table 9

LEVEL 2 FUNCTIONS (ADJUSTABLE PARAMETERS)				
Entry LED	Parameter	LED (level)	Set value	Description
L1*	Pause Time	L1	10 seconds	Adjusts the pause time, in other words, the time before automatic re-closure. It is only effective if the "Automatic Closing" function is enabled.
		L2	20 seconds	
		L3	40 seconds	
		L4	60 seconds	
		L5	80 seconds	
		L6	120 seconds	
		L7	160 seconds	
		L8	200 seconds	
L2**	Step-by-Step function	L1	Open - Stop - Close - Stop	Controls the sequence of controls associated with the Sbs input or the 1st radio command.
		L2	Open - Stop - Close - Open	
		L3	Open - Close - Open - Close	
		L4	Condominium	
		L5	Condominium 2 (more than 2 sec triggers "Stop")	
		L6	Step-by-Step 2 (more than 2 sec triggers "Partial Open")	
		L7	Hold-to-run	
		L8	Opening in "semi-automatic" mode, closing in "hold-to-run" mode	
L3*	Motor speed	L1	Speed 1 (30% - slow)	Adjusts the motor speed during normal manoeuvres.
		L2	Speed 2 (44%)	
		L3	Speed 3 (58%)	
		L4	Speed 4 (72%)	
		L5	Speed 5 (86%)	
		L6	Speed 6 (100% - fast)	
		L7	Open V4, close V2	
		L8	Open V6, close V4	

LEVEL 2 FUNCTIONS (ADJUSTABLE PARAMETERS)				
Entry LED	Parameter	LED (level)	Set value	Description
L4**	FLASH output	L1	Door Open Indicator	Selects the device connected to the FLASH output.
		L2	Enabled if door closed	
		L3	Enabled if door open	
		L4	Warning light	
		L5	Electric latch	
		L6	Electric lock	
		L7	Suction cup	
		L8	Maintenance indicator	
L5*	Motor force on opening	L1	Force 1 (low)	Adjusts the motor force control system to adapt it to the weight of the door during the opening manoeuvre.
		L2	Force 2	
		L3	Force 3	
		L4	Force 4	
		L5	Force 5	
		L6	Force 6	
		L7	Force 7	
		L8	Force 8 (high)	
L6*	Motor force on closing	L1	Force 1 (low)	Adjusts the motor force control system to adapt it to the weight of the door during the closing manoeuvre.
		L2	Force 2	
		L3	Force 3	
		L4	Force 4	
		L5	Force 5	
		L6	Force 6	
		L7	Force 7	
		L8	Force 8 (high)	
L7*	Maintenance notice	L1	Automatic (depending on the severity of the manoeuvres)	Adjusts the number of manoeuvres after which the automation maintenance request is triggered (see the “ Maintenance notice ” function” paragraph).
		L2	1000	
		L3	2000	
		L4	4000	
		L5	6000	
		L6	8000	
		L7	10000	
		L8	12000	
L8	List of malfunctions	L1	Result of 1st manoeuvre (most recent)	Allows for viewing the type of anomalies that occurred in the last 8 manoeuvres (refer to the “ Anomaly log ” paragraph). This is a read-only parameter, which means that its values cannot be modified.
		L2	Result of 2nd manoeuvre	
		L3	Result of 3rd manoeuvre	
		L4	Result of 4th manoeuvre	
		L5	Result of 5th manoeuvre	
		L6	Result of 6th manoeuvre	
		L7	Result of 7th manoeuvre	
		L8	Result of 8th manoeuvre	

All parameters can be adjusted as desired without any problems; only the “Motor force on opening” and “Motor force on closing” settings require special attention:

- high force values should not be used to compensate for points of abnormal friction on the leaf. Excessive force can jeopardise the operation of the safety system or damage the leaf
- if the “Motor Force” control is used to aid the impact force reduction system, measure the force again after each adjustment in accordance with the EN 12445 standard
- wear and atmospheric conditions influence the door’s movement, so the force settings should be checked periodically.

(*) If the value of a parameter falls between two adjacent values, the control unit will switch on intermittently the two LEDs identifying the value itself. If necessary, the values can be rounded off by pressing the ▲ or ▼ button to round off respectively to the higher or lower value among the two values highlighted by the control unit.

Example: Maintenance warning = 7000 manoeuvres - LEDs L5 and L6 flash. Pressing the ▼ button rounds off to value L5 (6000), while pressing the ▲ button rounds off to value L6 (8000).

If the value of a parameter is below the minimum value or above the maximum value among those listed in the table, the control unit will switch on intermittently LED L1 or L8 respectively. If necessary, the values can be rounded off by pressing the ▲ or ▼ button to round off to the nearest value.







Example: Pause Time = 5 seconds - LED L1 will flash. Pressing the ▲ button rounds off to value L1 (10 s) and L1 will no longer flash because the parameter will have been rounded off to a known value.

(**) If the configuration has not been learned, when LEVEL 2 of the MENU opens up, the control unit will propose the default configuration.

7.4 PROGRAMMING THE DIRECTION

This procedure allows for reversing the motor's rotation direction.

To do this:

1. press and hold the  button for roughly 3 seconds
2. release the  button when LED "L1" starts flashing
3. simultaneously press the  and  buttons to change the motor's direction
4. release the  and  buttons:
 - the lit courtesy light signals that the reversal of the motor direction has been programmed
 - if the courtesy light is off, the standard motor rotation direction has been programmed.
5. wait 10 seconds to exit the programming mode due to the expiry of the maximum time limit.

Note Points 3 and 4 can be repeated during the same programming phase to change the direction of motor rotation.



When the direction of motor rotation is changed, the "Position memorisation" procedure must be repeated (refer to the "Learning of the door opening and closing positions" paragraph).

At the end of the programming procedure, it is necessary to verify the direction of motor rotation.

To do this:

1. disconnect the power supply (by removing the plug or fuse)
2. power the device
3. after the initial flashing of LEDs "L1 ... L8", a single LED light up to signal the encoder position
4. on the signal indicating the encoder position, check the courtesy light:
 - if the courtesy light switches on, the reversed direction of motor rotation has been programmed
 - if the courtesy light is off, the standard motor rotation direction has been programmed.

7.5 RESETTING THE ENCODER POSITION



This procedure allows for restoring the encoder to the factory-set position to enable the assembly of **Soon** with the door closed. At the same time, it will reset the factory settings in the memory: all the parameters and the settings chosen by the user will be restored.

If the motor's direction of rotation must be modified, first run the "**Programming the direction**" procedure then the "**Resetting the encoder position**" procedure.



The procedure described below must be performed exclusively on a workbench. Do not perform the procedure with the motor installed.

To do this:

1. press and hold the  and  buttons until all LEDs from "L1" to "L8" light up.
2. release the buttons when only one lights up again (from "L1" to "L8") to signal the current position of the encoder
3. press and release the  button when the motor restarts. The control unit commands the motor's movement to bring the encoder position to LED "L7"
4. once the motor has stopped, all LEDs switch on and then off; at this point, check that the LED that lights up again is "L7". If this does not occur, repeat the procedure
5. at the end of the sequence, LEDs "L1" and "L2" continue to flash.

7.6 SPECIAL FUNCTIONS

7.6.1 "ALWAYS OPEN" FUNCTION

The "Always open" function is a control unit feature that enables the user to always command an opening manoeuvre when the "**Step-by-Step**" command lasts longer than 2 seconds; this is useful, for example, for connecting a timer contact to the SbS terminal in order to keep the gate open for a certain time frame.

This feature is valid regardless of how the "SbS" input is programmed, unless it is programmed to perform the "Condominium 2" function. Refer to the "**Step-by-Step function**" under the "**Level 2 programming (adjustable parameters)**" paragraph.

7.6.2 "MOVE ANYWAY" FUNCTION

This function can be used to operate the automation even one or more some safety devices fail to work properly or are out of order. The automation can be controlled in "**hold-to-run**" mode by proceeding as follows:

1. send a command to operate the gate, using a transmitter or key selector, etc. If everything functions properly, the gate will move normally, otherwise proceed with point 2
2. within 3 seconds, press the control again and hold it down
3. after roughly 2 seconds, the gate will complete the requested manoeuvre in "**hold-to-run**" mode, in other words, it will continue to move so long as the control is held down.



When the safety devices fail to work, the flashing indicator will flash a few times to signal the type of problem. To verify the type of anomaly, consult the "Signalling through warning light" chapter (page 22).

7.6.3 "MAINTENANCE NOTICE" FUNCTION

This function notifies the user when the automation needs a maintenance check. The number of manoeuvres after which the signal is triggered can be selected among 8 levels, through the "**Maintenance notice**" adjustable parameter (see paragraph "**Level 2 programming (adjustable parameters)**").

Level 1 adjustment is "automatic" and takes into account the severity of the manoeuvres, in other words, their force and duration, while the other adjustments are defined on the basis of the number of manoeuvres.

The maintenance signal is sent through the Flash warning light or the maintenance indicator, depending on the relative settings (see paragraph "**Level 2 programming (adjustable parameters)**").



The "Flash" warning light and the maintenance indicator give the signals indicated in "Table 10" based on the number of manoeuvres completed with respect to the set limit.

Table 10

MAINTENANCE NOTICE THROUGH FLASH AND MAINTENANCE INDICATOR		
Number of manoeuvres	Signal on "Flash"	Maintenance indicator signal
Below 80% of the limit	Normal (0.5 sec on, 0.5 sec off)	Lit for 2 seconds at the start of the opening manoeuvre
Between 81% and 100% of the limit	Remains lit for 2 seconds at the start of the manoeuvre	Flashes for the entire duration of the manoeuvre
Exceeding 100% of the limit	Remains lit for 2 seconds at the start and end of the manoeuvre then carries on normally	Flashes always

7.7 VERIFYING THE NUMBER OF MANOEUVRES COMPLETED

The "Maintenance notice" function can be used to verify the number of manoeuvres completed as a percentage of the set limit.

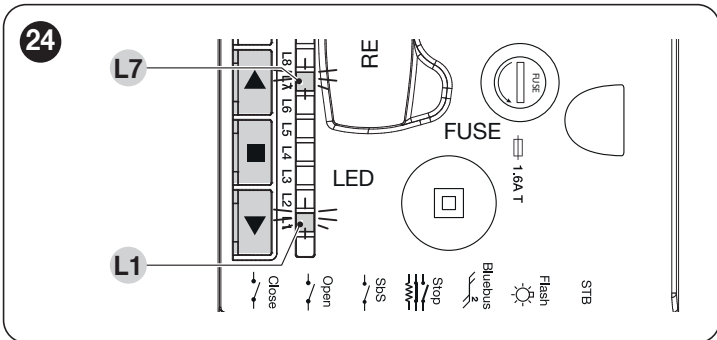

To do this:

- press and hold the **■** button until LED "L1" starts flashing
- release the **■** button when LED "L1" starts flashing
- press the **▲** or **▼** button to shift the flashing LED to "L7", that is, the "entry LED" for the "Maintenance notice" parameter
- press and hold the **■** button. With the **■** button pressed:
 - wait roughly 3 seconds until the LED representing the current level of the "Maintenance notice" parameter lights up
 - press and immediately release the **▲** and **▼** buttons
 - the LED corresponding to the selected level will flash a few times; the number of flashes indicates the percentage of manoeuvres performed (in multiples of 10%) with respect to the set limit. For example: with the maintenance notice set to L7 namely 10000, 10% corresponds to 1000 manoeuvres; if the visualisation LED flashes 4 times, it means that 40% of the manoeuvres has been reached (being between 4000 and 4999 manoeuvres). If 10% of the manoeuvres has not yet been reached, the LED does not flash at all.
- release the **■** button.

7.8 MANOEUVRE COUNTER RESETING

Once maintenance has been performed on the system, the manoeuvre counter must be reset.

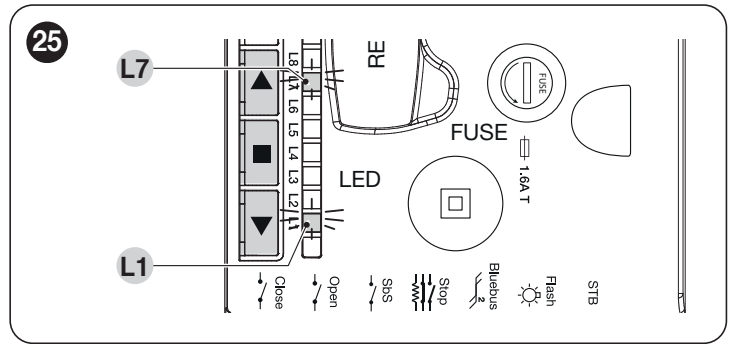

To do this:

- press and hold the **■** button until LED "L1" starts flashing
- release the **■** button when LED "L1" starts flashing
- press the **▲** or **▼** button to shift the flashing LED to "L7", that is, the "entry LED" for the "Maintenance notice" parameter
- press and hold the **■** button. With the **■** button pressed:
 - wait roughly 3 seconds until the LED representing the current level of the "Maintenance notice" parameter lights up
 - press and hold for at least 5 seconds the **▲** and **▼** buttons then release them. The LED corresponding to the selected level will emit a series of fast flashes to signal that the manoeuvre counter has been reset
- release the **■** button

7.9 MEMORY DELETION



The procedure described below restores the control unit's default settings. All the custom settings will be lost.

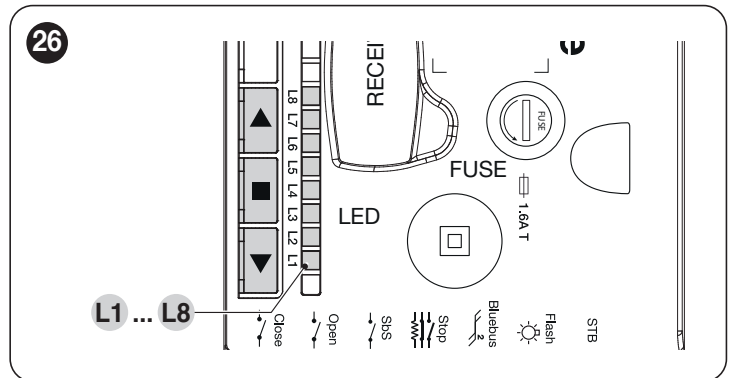

To delete the control unit's memory and restore all the default settings, proceed as described below:

- press and hold the **▲** and **▼** buttons until the programming LEDs "L1-L8" light up (after roughly 3 seconds)
- release the buttons
- if the operation was successful, the programming LEDs "L2" and "L8" will flash rapidly for 3 seconds.



With this procedure it is possible to also delete any errors left in the memory.



This procedure does not cancel the parameter relative to the motor's rotation direction and the number of manoeuvres executed.

8.1 TROUBLESHOOTING

The table below contains useful instructions to resolve any malfunctions or errors that may occur during installation or in case of a fault.

Table 11

TROUBLESHOOTING	
Problems	Recommended checks
The radio transmitter does not control the automation and the LED on the transmitter fails to light up	Check whether the transmitter batteries are exhausted and replace them if necessary.
The radio transmitter does not control the automation but the LED on the transmitter lights up	Check whether the transmitter has been memorised correctly in the radio receiver.
No manoeuvre starts and the "BlueBUS" LED does not flash	Check that the gearmotor is being powered with the mains voltage Check whether fuses F1 and F2 are blown; if they are, identify the cause of the failure then replace the fuses with others having the same current rating and characteristics.
No manoeuvre starts and the warning light is off	Check that the command is actually received. If the command reaches the Step-by-Step input, the corresponding "SbS" LED must light up; if instead the radio transmitter is used, the "BlueBUS" LED must emit two quick flashes.
No manoeuvre starts and the warning light flashes a few times	Count the number of flashes and check the corresponding value in "Table 13".
The manoeuvre starts but is immediately followed by a reverse run	The selected force value may be too low to move the type of gate. Check whether there are any obstacles and, if necessary, select a higher force. Check whether a safety device connected to the Stop input has tripped.
The manoeuvre is completed correctly but the warning light does not work	Make sure that there is voltage on the warning light's FLASH terminal during the manoeuvre (being intermittent, the voltage value is not significant: roughly 10–30 V $\overleftrightarrow{=}$); if there is voltage, the problem is due to the lamp, which must be replaced with one having the same characteristics; if there is no voltage, there may have been an overload on the FLASH output. Check that the cable has not short-circuited.
LED "L1" or LED "L8" flashes rapidly	This means that the high overrun position (LED "L1" flashes rapidly) or the low overrun position (LED "L8" flashes rapidly) has been reached. If LED "L1" flashes, perform a closing manoeuvre until LED "L1" stops flashing rapidly. Then detach Soon from the spring support shaft, open the door to the maximum position and re-install Soon from this position. If LED "L8" flashes, perform an opening manoeuvre until LED "L8" stops flashing rapidly. Then detach Soon from the spring support shaft, close the door to the maximum position and re-install Soon from this position.

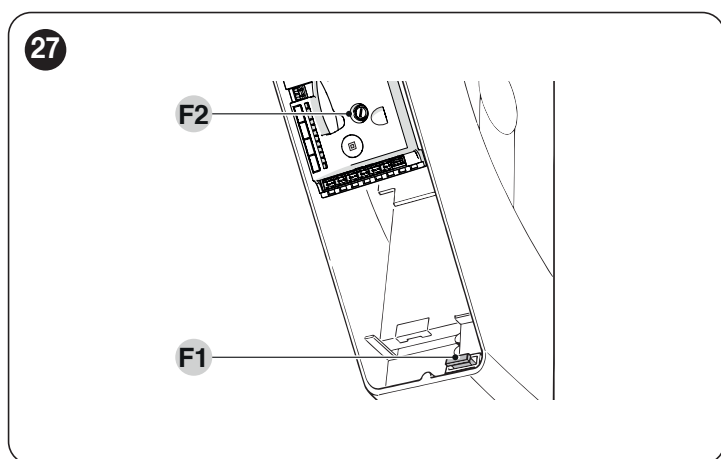



Table 12

CHARACTERISTICS OF FUSES F1 AND F2	
F1	Mains Power Supply Fuse = 1.6A
F2	Control Unit Fuse = 1.6 Delayed





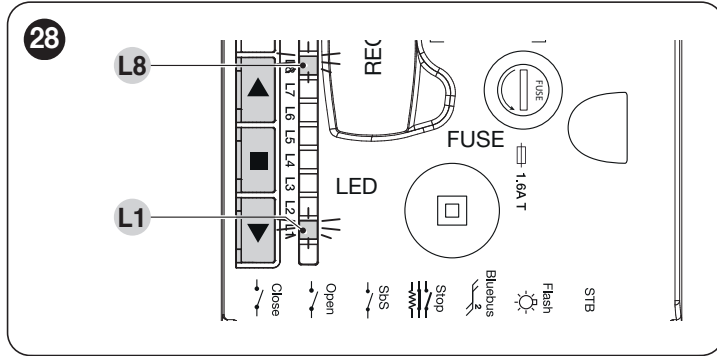

8.2 ANOMALY LOG

The gearmotor allows for displaying any anomalies that occurred in the last 8 manoeuvres, for example, the interruption of a manoeuvre due to the intervention of a photocell or sensitive edge.

To do this:

1. press and hold the  button until LED "L1" starts flashing
2. release the  button when LED "L1" starts flashing



3. press the  or  button to shift the flashing LED to "L8", that is, the "entry LED" for the "List of anomalies" parameter
4. press and hold the  button. With the  button pressed:
5. wait roughly 3 seconds, after which the LEDs corresponding to the manoeuvres that had anomalies will light up. LED L1 indicates the result of the most recent manoeuvre, while LED L8 indicates the result of the eighth manoeuvre. If the LED is lit, it means that anomalies occurred during the manoeuvre; if the LED is off, the manoeuvre terminated without any anomalies
6. press the  or  button to select the desired manoeuvre: the corresponding LED will flash the same number of times as those emitted by the warning light following an anomaly (see "Table 13")
7. release the  button.

8.3 SIGNALLING THROUGH WARNING LIGHT

During the manoeuvre, the "FLASH" warning light flashes once every second; whenever anomalies occur, shorter flashes are emitted; the flashes are repeated twice with a one-second pause in between.

Table 13

FLASH WARNING LIGHT SIGNALS		
Fast flashes	Cause	ACTION
2 flashes 1-second pause 2 flashes	Intervention of a photocell	At the start of the manoeuvre, one or more photocells are blocking the movement; check whether there are any obstacles. During the manoeuvre, this is normal if an obstacle is present.
3 flashes 1-second pause 3 flashes	Intervention of the "Motor Force" limiter	During the movement, the door experienced excessive friction; identify the cause.
4 flashes 1-second pause 4 flashes	Intervention of the STOP input	At the start of the manoeuvre or during the movement, the STOP input intervened; identify the cause.
5 flashes 1-second pause 5 flashes	Error in the internal parameters of the control unit	Wait at least 30 seconds then try giving a command; if the condition persists, it means that there is a serious malfunction and the electronic board must be replaced.
6 flashes 1-second pause 6 flashes	The maximum number of manoeuvres per hour limit has been exceeded	Wait a few minutes until the manoeuvre limiter drops below the maximum limit.
7 flashes 1-second pause 7 flashes	Error in the internal electric circuits	Disconnect all the power circuits for a few seconds and then try giving a command again; if the condition persists, it means there is a serious fault on the electronic board or on the motor cabling. Perform any necessary checks and replacements.
8 flashes 1-second pause 8 flashes	A command that prevents other commands from being executed is already present	Another command is already present. Remove the command present to be able to send other commands.
9 flashes 1-second pause 9 flashes	The automation was stopped by a "Stop automation" command	Unlock the automation mechanism by giving the "Unlock automation" command.

8.4 SIGNALS ON THE CONTROL UNIT

The control unit has a series of LEDs, each of which can emit special signals both during regular operation and when an anomaly occurs.

- A BlueBus LED
- B Close, Open, Sbs, Stop LEDs
- C "L1 ... L8" programming LEDs
- D Courtesy light

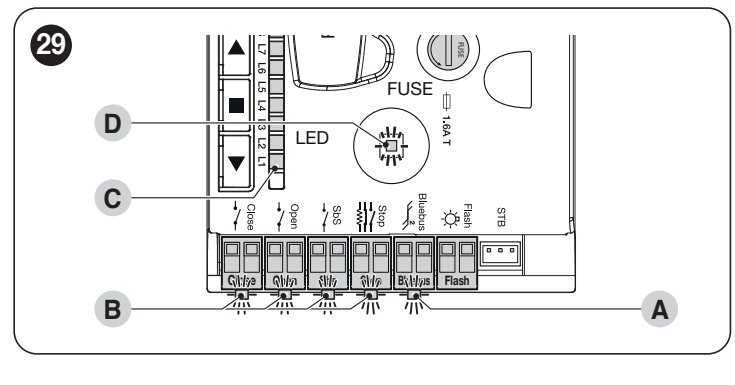

Table 14

TERMINAL LEDS ON THE CONTROL UNIT

Status	Meaning	Possible solution
BlueBus LED		
OFF	Anomaly	Check for the presence of power; check that the fuses are not blown; if necessary, identify the cause of the fault then replace them with fuses having the same specifications.
On	Serious anomaly	There is a serious anomaly; try switching off the control unit for a few seconds; if the condition persists, it means that there is a fault and the electronic circuit board must be replaced.
1 green flash per second	Everything normal	Normal control unit operation.
2 quick green flashes	The status of the inputs has changed	This is normal when there is a change in one of the inputs: SBS, STOP, OPEN, CLOSE, the photocells intervene or the radio transmitter is used.
A series of flashes separated by a 1-second pause	Various	Refer to that shown in "Table 13".
A series of quick and extended red flashes	Short circuit on the BlueBUS terminal clamp	Disconnect the terminal and verify the cause of the short-circuit on the BlueBUS connections. If the short-circuit is resolved, the LED will start flashing normally after about ten seconds.
Slow red and green flashing	Backup batteries charging with Standby Mode running	Normal system operation. Occurs only with updated backup batteries for Standby products.
STOP LED		
OFF	Intervention of the STOP input	Check the devices connected to the STOP input.
On	Everything normal	STOP input active.
Sbs LED		
OFF	Everything normal	Sbs input not active.
On	Intervention of the Sbs input	This is normal if the device connected to the Sbs input is actually active.
OPEN LED		
OFF	Everything normal	OPEN input not active.
On	Intervention of the OPEN input	This is normal if the device connected to the OPEN input is actually active
CLOSE LED		
OFF	Everything normal	CLOSE input not active.
On	Intervention of the CLOSE input	This is normal if the device connected to the CLOSE input is actually active.

Table 15

CONTROL UNIT COURTESY LIGHT

Status	Description
OFF	Automation Stopped
Steady Lit	Manoeuvre in progress
On 3 sec	Automation Lock Command Executed
Flashes	The control unit must run the automatic force search procedure (refer to the " Learning of the door opening and closing positions " paragraph). If the courtesy light flashes also during the manoeuvre, it means that a procedure is under way to detect the critical points of the manoeuvre. If it flashes synchronously with the warning light, there is an anomaly (refer to "Table 13").

LEDS ON THE CONTROL UNIT BUTTONS	
LED 1	Description
OFF	During normal operation, this indicates that “Automatic Closing” is disabled.
On	During normal operation, this indicates that “Automatic Closing” is active.
Flashes	Function programming in progress. With the motor stationary, if it flashes individually it means that the encoder position is in the Low Overrun position (position below or equal to 5%). Adjust the position then rerun the position search procedure. If it flashes together with “ L2 ”, it means that the device learning phase must be carried out (refer to the “ Device learning ” paragraph).
LED 2	Description
OFF	During normal operation, it signals that the “Close after photo” mode is not active.
On	During normal operation, it signals that the “Close after photo” mode is active.
Flashes	Function programming in progress. If it flashes together with “ L1 ”, it means that the device learning phase must be carried out (see the “ Device learning ” paragraph).
LED 3	Description
OFF	During normal operation, this indicates that “Always Close” is not active.
On	During normal operation, it signals that “Always close” is active.
Flashes	Function programming in progress. If it flashes together with L4, it means that the door opening and closing positions must be learned (refer to the “ Learning of the door opening and closing positions ” paragraph).
LED 4	Description
OFF	During normal operation, it signals that the “Stand-by” mode is not active.
On	During normal operation, it signals that the “Stand-by” mode is active.
Flashes	Function programming in progress. If it flashes together with L3, it means that the door opening and closing positions must be learned (refer to the “ Learning of the door opening and closing positions ” paragraph).
LED 5	Description
OFF	During normal operation, it indicates that “Long reversal” is not enabled.
On	During normal operation, it indicates that “Long reversal” is enabled.
Flashes	Function programming in progress.
LED 6	Description
OFF	During normal operation, it signals that the “Pre-flashing” mode is not active.
On	During normal operation, it signals that the “Pre-flashing” mode is active.
Flashes	Function programming in progress.
LED 7	Description
OFF	During normal operation, it indicates that “Sensitivity” is not enabled.
On	During normal operation, it indicates that “Sensitivity” is enabled.
Flashes	Function programming in progress.
LED 8	Description
OFF	During normal operation, it indicates that the installation includes 1 motor.
On	During normal operation, it indicates that the installation includes 2 motors.
Flashes	Function programming in progress. With the motor stationary, if it flashes individually it means that the encoder position is in the High Overrun position (position above or equal to 95%). Adjust the position then rerun the position search procedure.

9.1 MODIFYING THE STOP INPUT CONFIGURATION

STOP is the input that causes immediate stoppage of the manoeuvre followed by its brief reversal. Devices with output featuring normally open "NO" and normally closed "NC" contacts, as well as devices with 8.2 kΩ fixed resistor output, such as sensitive edges, can be connected to this input.

As with the BlueBUS, the control unit recognises the type of device connected to the STOP input during the learning phase (see the "Device learning" paragraph); subsequently the control unit gives a STOP command when it detects a variation with respect to the learned status.

Multiple devices, even of different types, can be connected to the STOP input if suitable arrangements are made:

- Any number of NO devices can be connected to each other in parallel.
- Any number of NC devices can be connected to each other in series.
- Two devices with 8.2 kΩ fixed resistor output can be connected in parallel; if there are more than 2 devices then they must all be connected in cascade, with a single 8.2 kΩ terminating resistor.
- It is possible to combine two NO and NC contacts by placing them in parallel, while also mounting a 8.2 kΩ resistor in series with the NC contact (this also allows for combining 3 devices: NA, NC and 8.2 kΩ).

! **If the STOP input is used to connect devices with safety functions, only those devices with 8.2 kΩ fixed resistor guarantee Category 3 safety against faults in accordance with the EN 13849-1 standard.**

Note: If the configuration at the STOP input is 8K2 or optical type, the behavior near the ground (defined by the parameter "Exclusion position") will be as follows:

- From full closure, an opening command with STOP intervened still allows the maneuver to start, only for the space defined by the "Exclusion Position".
- During closure, the intervention of the STOP within the space defined by the "Exclusion Quota" will cause a stop, which will be interpreted by the control unit as a total closure.

9.2 CONNECTING AN SM-TYPE RADIO RECEIVER

This product has a RADIO connector on which accessory cards can be plugged for additional functions. The power consumption of accessories has not been considered in the Standby Mode consumption calculation. Check the respective instructions for the consumption of these accessories.

The control panel has a seat to accommodate SM plug-in radio receivers (optional accessories) that allow the control panel to be controlled remotely via transmitters acting on the control panel inputs.



Before installing a receiver, disconnect the power supply to the control unit.

To install a receiver ("Figure 30"):

1. insert the receiver (A) in the appropriate slot (B) on the control unit's electronic board.

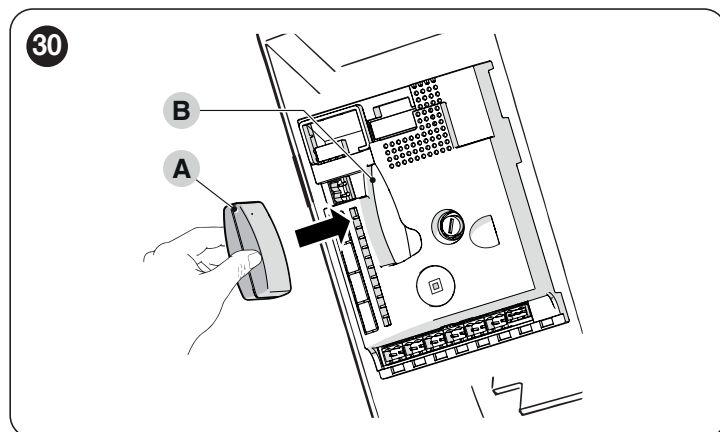

Plug the antenna into the terminal of the radio receiver (refer to the receiver's instructions)

The association between the radio receiver output and the command executed by the motor is shown in "Table 17":

Table 17

SMXI / SMXIS	
Receiver output	Command
Output No. 1	"Step-by-Step"
Output No. 2	"Partial opening"
Output No. 3	"Open"
Output No. 4	"Close"

If the OXI radio receiver used in "EXTENDED MODE" is installed, it may send the commands shown in "Table 18".

Table 18

OXI / OXIFM / OXIT / OXITFM IN MODE 2 EXTENDED		
No.	Command	Description
1	Step-by-Step	"SbS" (Step-by-Step) command
2	Partial opening 1	"Partial opening 1" command
3	Open	"Open" command
4	Close	"Close" command
5	Stop	Stops the manoeuvre
6	Condominium Step-by-Step	Command in condominium mode
7	High priority Step-by-Step	Commands also with the automation locked or the commands enabled
8	Partial open 2	Partial opening (the M2 gate leaf opens to 1/2 the full length)
9	Partial open 3	Partial open (the two gate leaves open to 1/2 the full length)
10	Opens and locks the automation	Triggers an opening manoeuvre and, once this terminates, locks the automation; the control unit will not accept any command other than "High priority Step-by-Step" and automation "Unlock", or (only from Oview) the following commands: "Unlock and close" and "Unlock and open"
11	Closes and locks the automation	Triggers a closing manoeuvre and, once this terminates, locks the automation; the control unit will not accept any command other than "High priority Step-by-Step" and automation "Unlock", or (only from Oview) the following commands: "Unlock and close" and "Unlock and open"
12	Lock automation	Triggers the stoppage of the manoeuvre and locks the automation; the control unit will not accept any command other than "High priority Step-by-Step" and automation "Unlock", or (only from Oview) the following commands: "Unlock and close" and "Unlock and open"
13	Release automation	Triggers unlocking of the automation and restores normal operation
14	On Timer Courtesy light	The courtesy light output switches on with timer-based switching off
15	On-Off Courtesy light	The courtesy light output switches on and off in Step-by-step mode

 For further information, consult the specific manual of the receiver.

9.3 CONNECTING AND INSTALLING THE EMERGENCY POWER SUPPLY

 **The electrical connection of the battery to the control unit must be made only after completing all the installation and programming stages, as the battery is an emergency power supply.**

This product can be equipped with an emergency power supply system that ensures operation even in the absence of mains power. The emergency power supply is through batteries that must be kept in the charged state. The battery charging function is one of the main functions of this product; the Standby Mode will be activated only when the battery charging function is completed.

Check the instructions of the emergency power system for the maximum time required for the batteries to be fully charged.

 **WARNING**
Use the pre-addressed backup battery pack for operation with Standby (PSS124) power packs. If the PS124 battery pack is used instead, it is necessary to disable the Standby Mode for proper operation.

To install and connect the battery:

1. remove the plastic protection (A) with the aid of a screwdriver

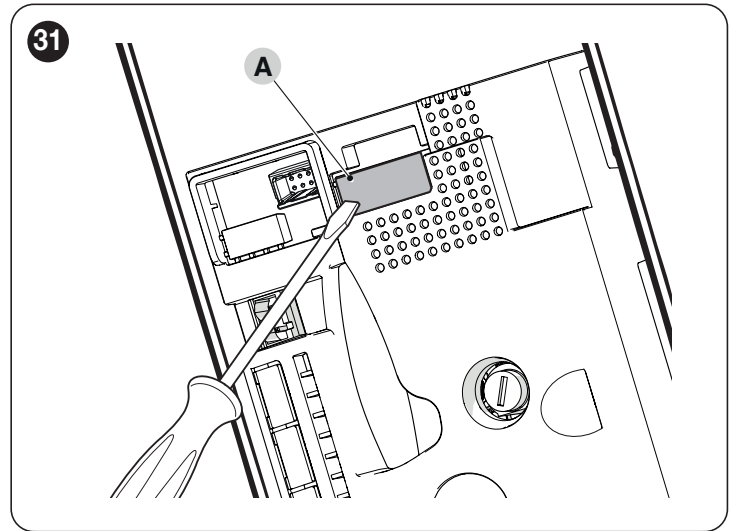

2. connect the appropriate cable to the back-up battery connector

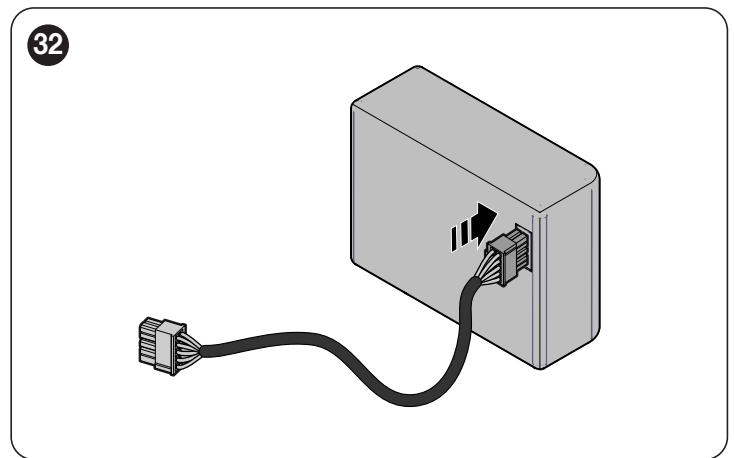

3. insert the relative connector (C) on the control unit

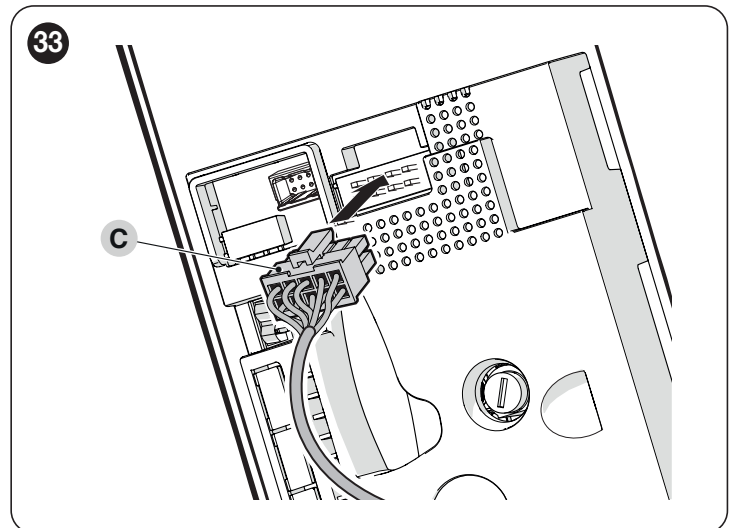

- insert the back-up battery (B) into its housing inside the motor body.

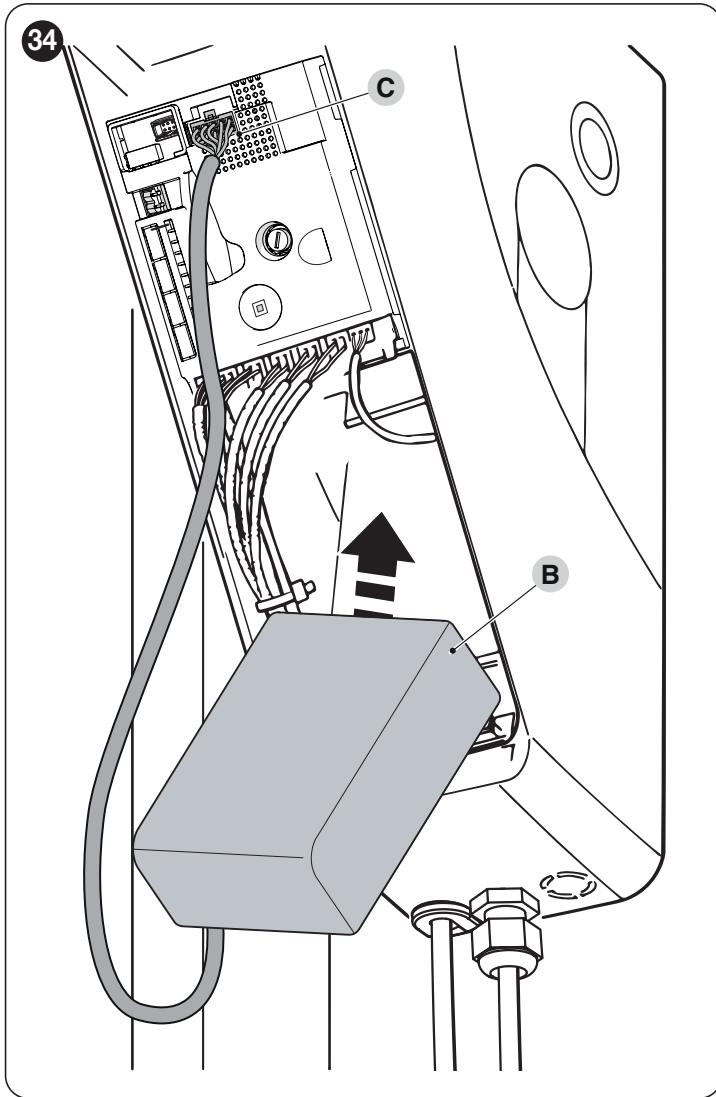

9.4 WI-FI CONNECTION

The **SO2000** engine is prepared for WiFi connectivity to enable:

- remote control of the automation (through the MyNice app)
- the installer: configuration of the automation (through the MyNice Pro app)

In particular, Wi-Fi connectivity is available with two modes:

- The BiDi-Wifi interface supplied on request as an accessory
- The Proview interface (only for the MyNice Pro app) supplied on request as an accessory



The application of the BiDi-Wi-Fi interface to the busT4 port present on the automation must be regarded as alternative to the BiDi-ZWave interface.

To use the automation's Wi-Fi connectivity in the available modes, it is necessary to:

- Install, depending on the desired use, the MyNice app or the MyNice Pro app (reserved for the installer) available on Google Play Store and Apple App Store
- Power the automation and verify that the available Wi-Fi device switches on normally
- Launch the installed app and configure the Wi-Fi device from the “Wi-Fi interface or Accessories” menu

For further details relative to the functions linked to the MyNice Pro and MyNice apps, consult the website www.niceforyou.com.

9.4.1 BIDI-WI-FI INTERFACE

To connect the BiDi-Wi-Fi interface:

- Disconnect the power supply to the control unit by removing the fuse F1 and, if necessary, the emergency power supply

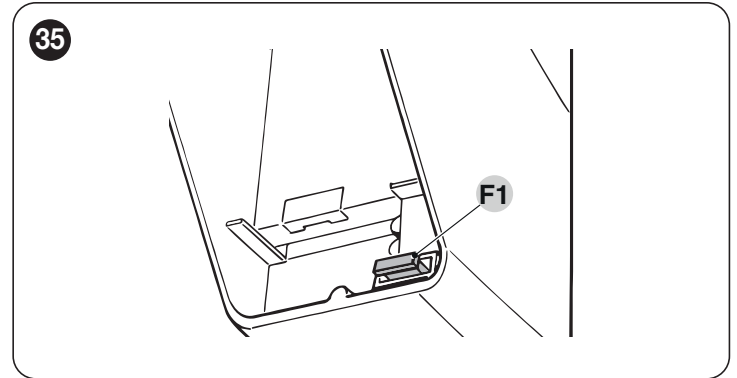

- Verify that all the control unit LEDs are switched off before proceeding

Insert the BiDi-Wi-Fi interface in the BUS T4 connector of the control unit

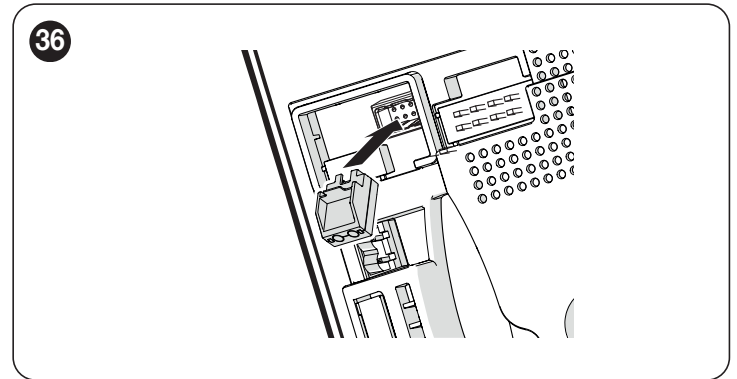

Warning! If it is not correctly inserted, the BiDi-Wi-Fi interface could get damaged or permanently damage the control unit.

- Insert fuse F1 to switch the control unit on again
- Wait for the **Date** LED to start flashing
- Configure the interface through the app
- Wait until the **Date** LED switches on and the green light stays steady lit. At this point the configuration will have been completed.



For further details relative to the functions linked to the BiDi-Wi-Fi interface, consult the website www.niceforyou.com.

9.5 CONNECTING THE SOLEMYO SOLAR ENERGY SYSTEM



When the automation is powered by the “Solemyo” system, IT MUST NOT BE POWERED by the electricity grid at the same time.



For information on the “Solemyo” system, consult the relevant instruction manual.

To connect the “Solemyo” system:

1. remove the plastic protection (A) with the aid of a screwdriver
2. insert the relative connector (B) on the control unit.

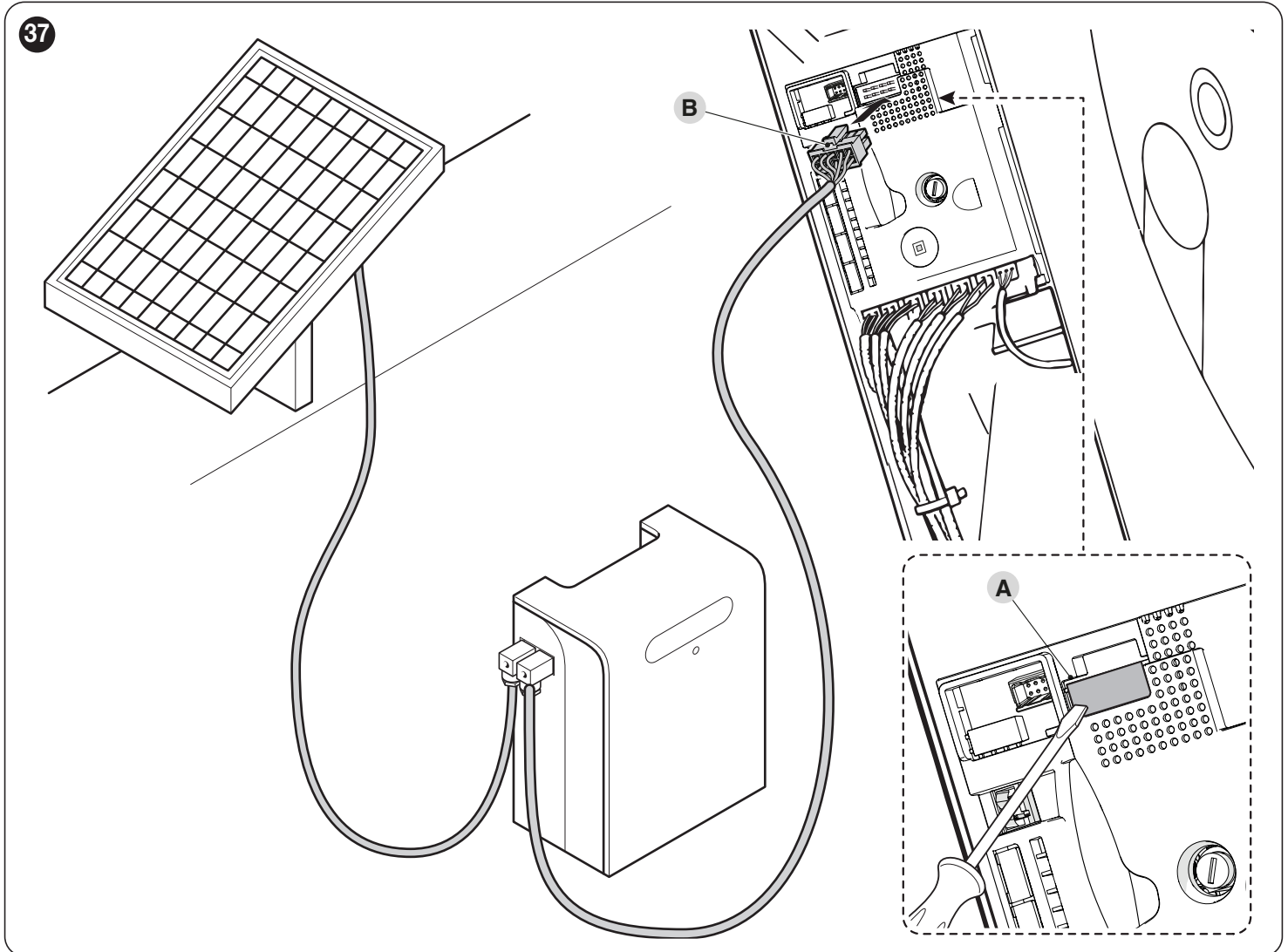

10 PRODUCT MAINTENANCE

The automation must be subjected to regular maintenance to keep its safety level constant and guarantee long-lasting operation; to this aim, **Soon** has a manoeuvre counter and maintenance warning system; refer to the “**Maintenance notice**” function” paragraph.



Maintenance must be carried out strictly in compliance with the safety provisions provided in this manual and in accordance with the laws and regulations in force.

To carry out maintenance on the gearmotor:

1. Schedule maintenance interventions within maximum 6 months or after maximum 4.000 manoeuvres from the previous maintenance intervention
2. disconnect all power supplies, including any back-up batteries
3. check for any deterioration in the materials making up the automation, with special emphasis on erosion or oxidation of the structural parts; replace any parts that are not to standard
4. check the state of wear of moving parts: pinion, rack and all gate leaf components; replace any worn parts
5. connect the power supplies again and run all the tests and checks described in the “**Testing**” paragraph (page 14).

11 PRODUCT DISPOSAL



This product is an integral part of the operator and must therefore be disposed of with it.

As with the installation, only qualified personnel must dismantle the product at the end of its life.

This product is composed of different types of materials. Some of these materials can be recycled; others must be disposed of. Please enquire about the recycling or disposal systems in place in your local area for this type of product.



WARNING

Some parts of the product may contain polluting or dangerous substances. If not disposed of correctly, these substances may have a damaging effect on the environment and human health.



As indicated by the symbol shown here, this product must not be disposed of with household waste. Separate the waste for disposal and recycling, following the methods stipulated by local regulations, or return the product to the seller when purchasing a new product.

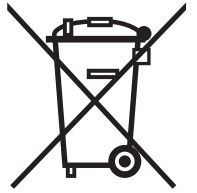

WARNING

Local regulations may impose heavy penalties if this product is not disposed of in compliance with the law.

12 TECHNICAL SPECIFICATIONS



All technical specifications stated in this section refer to an ambient temperature of 20°C (± 5°C). Nice S.p.A. reserves the right to apply modifications to the product at any time when deemed necessary, without altering its functions and intended use.

Table 19

TECHNICAL SPECIFICATIONS	
Description	Technical specification
Product type	Electromechanical gearmotor for sectional doors
Power supply	230V~ (+10% -15%) 50/60Hz
Maximum current draw (A)	1,5
Nominal current draw (A)	1
Maximum torque (Nm)	50
Nominal torque (Nm)	30
Maximum power consumption (W)	350
Nominal power consumption (W)	220
Standby Mode Power (W)	< 0,3
Maximum speed (rpm)	30
Nominal speed (rpm)	18
Static holding torque (Nm)	130
Protection rating (IP)	40
Operating temperature (min/max °C)	-20°C ÷ 50°C
Maximum door surface area (m ²)	20
Maximum door height (m)	5
Insulation class	I
Durability	Estimated between 40,000 and 120,000 cycles, depending on the conditions specified in the "Product durability" paragraph
Cycles per hour at the rated torque – for doors with 3 m height (cycles/hour)	15
Dimensions (mm)	115x375x300
Weight (kg)	10,5
Hole (mm)	25,5
Emergency power supply	Yes (PS124 battery)
Courtesy light	Integrated with LED
Warning light output[Note 1]	For 1 LUCYB warning light; MLB or MLBT (12 V, 21 W lamp)
BLUEBUS output	One output with maximum load of 12 BlueBUS units
STOP input	For normally closed or normally open contacts or for 8.2 kΩ fixed resistor contacts with self-learning (any variation from the memorised status triggers the STOP command)
Sbs input[Note 2]	For normally open contacts (closing of the contact triggers the STEP-BY-STEP command)
OPEN input[Note 2]	For normally open contacts (closing of the contact triggers the "OPEN" command)
CLOSE input[Note 2]	For normally open contacts (closing of the contact triggers the CLOSE command)
Radio ANTENNA input	52 Ω for RG58-type cable or similar
Programming input	For 1 OVIEW programmer with 4-pin telephone cable and RJ14 connector
Radio connector	SM connector for SMXI, SMXIS or OXI receivers
Programmable functions	8 ON-OFF and 8 adjustable functions
Self-learning functions	Self-learning of the devices connected to the BlueBus output Self-learning of the type of "STOP" device (Normally Open, Normally Closed contact or 8.2 kΩ resistor) Self-learning of the gate length and calculation of the deceleration and partial opening points
Stand-By mode	Automatic: 5 minutes after the end of the main functions
Use in highly acid, saline or potentially explosive atmosphere	No

Note 1 The output can be programmed with other functions (see **"Table 9"** or through the Oview programmer).

Note 2 The inputs can be programmed with other functions through the Oview programmer.

EU Declaration of Conformity and declaration of incorporation of “partly completed machinery”

The EU declaration of conformity can be downloaded from the website www.niceforyou.com

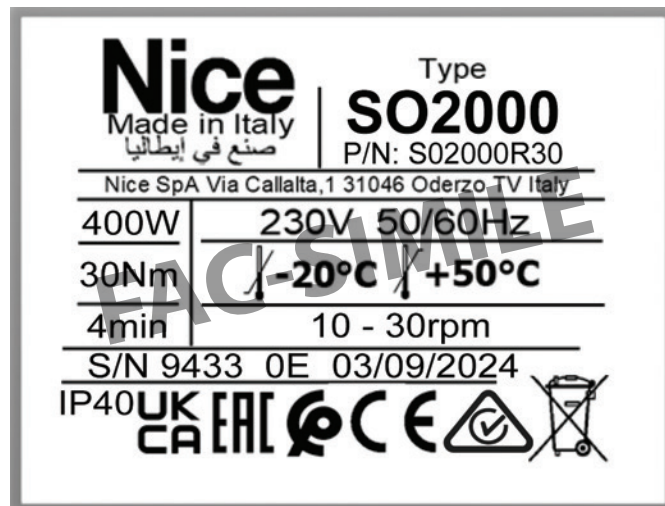

Before using the automation system for the first time, ask the installer to explain the origin of residual risks and take a few minutes and read this instructions manual and related warnings handed to you by the installer. Keep the manual for consultation when in doubt and ensure supply to new owners of the automation.

WARNING!

Your automation is a machine that faithfully executes commands imparted by the user. Negligence and improper use may lead to dangerous situations:

- do not manoeuvre the gate if there are people, animals or objects within its range of operation
- it is strictly forbidden to touch parts of the automation while it is moving
- the photocells should not be regarded as actual safety devices but only as auxiliary safety devices. They are designed using highly reliable technology, but in extreme conditions may be subject to malfunctions or potential faults, and in certain cases these faults might not be immediately evident
- periodically check that the photocells work properly.

 **IT IS STRICTLY FORBIDDEN to transit while the automation is closing! Transit is allowed only if the automation is fully open and stationary.**

CHILDREN

An automation system guarantees a high degree of safety. With its detection systems, it can control and guarantee the gate's movement in the presence of people or objects. It is nonetheless advisable to forbid children from playing near the automation and not to leave remote controls near them to prevent any unwanted activation of the system. The automation is not a toy!

The product is not intended for use by persons, including children, with limited physical, sensory or mental capacities, or who lack experience or knowledge, unless supervised or trained in the use of the product by a person responsible for their safety.

Anomalies: if the automation shows any signs of anomalous behaviour, disconnect the power supply to the system and manually unlock the motor (see instructions at the end of the chapter) to manoeuvre the automation manually. Do not attempt any repairs personally, but contact your trusted installer.

 **Do not modify the system or the programming and adjustment parameters of the control unit: your installer is exclusively responsible for these operations.**

Failure or lack of power supply: while waiting for the installer to intervene or the electricity to be restored, if the system is not equipped with emergency power supplies, the automation can nonetheless be used by manually unlocking the motor (see the instructions at the end of the chapter) and moving the automation manually.

Safety devices out of order: the automation can also be used when one or more safety devices are defective or out of order. The automation can be controlled in **"Hold-to-run"** mode in the following way:

1. send a command to operate the automation using a transmitter or key selector, etc. If everything works normally, the automation will move regularly, otherwise the warning light will flash a few times and the manoeuvre will not start (the number of flashes depends on the reason for which the manoeuvre cannot start)
2. in this case, within 3 seconds press the control again and hold it down
3. after roughly 2 seconds, the automation will complete the requested manoeuvre in **"Hold-to-run"** mode, in other words, it will continue to move so long as the control is held down.

 **If the safety devices are out of order, have the system repaired as soon as possible by a qualified technician.**

The test, periodic maintenance and any repairs must be documented by the person carrying out the work and the documents must be stored by the owner of the automation. The only interventions the user may carry out periodically include cleaning of the photocell glass components (use a soft and slightly damp cloth) and removing any leaves or stones that may obstruct the automation.

 **Before carrying out any maintenance operations, the user of the automation must manually unlock the motor to prevent anyone from accidentally triggering the automation's movement (see the instructions at the end of the chapter).**

Maintenance: in order to ensure constant levels of safety and the longest useful life for the automation, routine maintenance must be carried out (at least every 6 months).

 **Only qualified personnel is authorised to carry out checks, maintenance operations and repairs.**

Disposal: at the end of its useful life, the automation must be dismantled by qualified personnel and the materials must be recycled or disposed of in compliance with the local regulations in force.

Replacing the remote control battery: if your remote control appears to be working poorly after some time, or stops working altogether, it may simply depend on flat batteries (depending on how much the device is used, the batteries may last from several months to over a year). You will notice this by the fact that the indicator light signalling the transmission fails to light up, is weak or lights up only for a short time. Before contacting the installer, try replacing the battery with that of another transmitter that works properly: if the anomaly is resolved, simply replace the flat battery with one of the same type.

Unlocking and manual movement

 **The gate can only be unlocked once the leaf has come to a standstill.**

The gearmotor is equipped with a mechanical unlocking device that can be used to open and close the door manually.

These manual operations should only be performed in case of a power outage, malfunctions or during the installation phases.

To unlock the device:

1. pull the releasing cord **(A)**
2. the door can now be moved manually to the desired position.

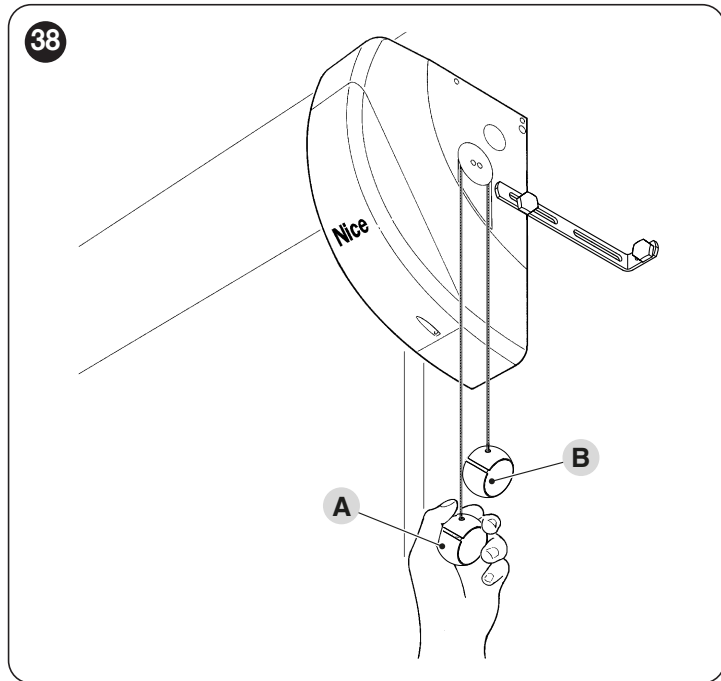

To lock the mechanism, pull the ball **(B)**.

NOTES

A series of horizontal dashed lines for writing notes.



Nice SpA
Via Callalta, 1
31046 Oderzo (TV)
Italia

www.niceforyou.com

IDV0643A03EN_28-05-2025