

Moonclever

MC800

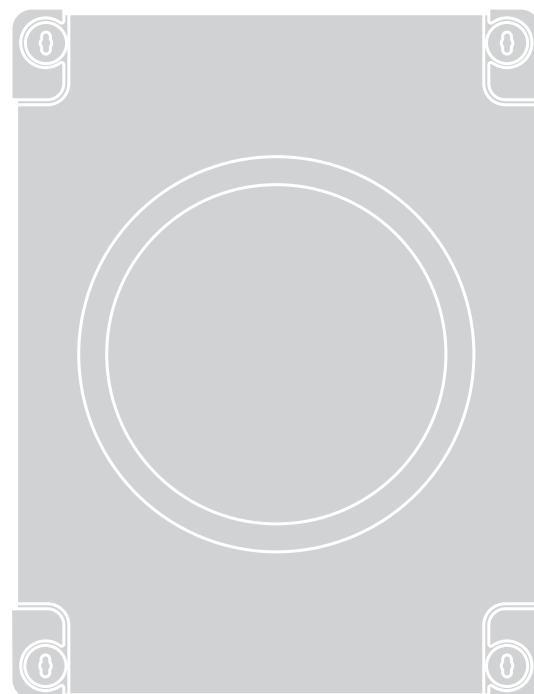

Control unit

EN - Instructions and warnings for installation

Nice

CONTENTS

1 GENERAL SAFETY WARNINGS AND PRECAUTIONS 2

2 PRODUCT DESCRIPTION AND INTENDED USE 3

2.1 List of control unit parts 3

3 INSTALLATION 4

3.1 Pre-installation checks 4

3.2 Product usage limits 4

3.3 Product identification and overall dimensions 4

3.4 Typical installation 4

3.5 Installing the control unit 5

4 ELECTRICAL CONNECTIONS 5

4.1 Preliminary checks 5

4.2 Wiring diagram and description of connections 6

4.2.1 Connection diagram with relay and Bluebus photocells in standby mode 6

4.2.2 Connection diagram with Bluebus photocells and motor limit switches 7

4.2.3 Connection diagram with relay and Bluebus photocells without phototest (standby mode deactivated) 8

4.2.4 Connection diagram with relay photocells with phototest (standby mode deactivated) 9

4.2.5 Description of connections 10

4.2.6 Operations for connection 11

4.2.7 Positioning the safety cable clamp 11

4.3 Connecting other devices to the control unit 11

4.4 Addressing of devices connected with the BlueBus system 11

4.5 Initial start-up and electrical connections test 12

4.5.1 Programming and verification of Standby mode 12

4.5.2 Programming with AUX inputs 12

4.6 Learning of connected devices 12

4.7 Selecting the type of motor (for hydraulic motors only) 12

4.8 Learning of the mechanical stop positions 13

4.8.1 Learning in automatic mode 13

4.8.2 Learning in manual mode 13

4.8.3 Learning in mixed mode 14

4.9 Checking the gate movement 14

5 TESTING AND COMMISSIONING 15

5.1 Testing 15

5.2 Commissioning 15

6 PROGRAMMING 15

6.1 Using the programming buttons 15

6.2 Level 1 programming (ON-OFF) 16

6.2.1 Level 1 programming procedure 16

6.3 Level 2 programming (adjustable parameters) 16

6.3.1 Level 2 programming procedure 16

6.4 Special functions 18

6.4.1 "Move anyway" function 18

6.4.2 "Maintenance notice" function (configurable with an external programmer) 18

6.5 Memory deletion 19

7 TROUBLESHOOTING GUIDE 19

8 FURTHER DETAILS (Accessories) 21

8.1 Connecting an SM-type radio receiver 21

8.2 Connecting the IBT4N interface 22

9 PRODUCT MAINTENANCE 22

10 PRODUCT DISPOSAL 22

11 TECHNICAL SPECIFICATIONS 23

12 CONFORMITY 23

INSTRUCTIONS AND WARNINGS FOR USE 25

1 GENERAL SAFETY WARNINGS AND PRECAUTIONS



WARNING! Important safety instructions. Observe all the instructions as improper installation may cause serious damages.



WARNING! Important safety instructions. It is important to comply with these instructions to ensure personal safety. Store these instructions carefully.



According to the latest European legislation, an automated device must be constructed in conformity to the harmonised rules specified in the current Machinery Directive, which allow for declaring the presumed conformity of the automation. Consequently, all the operations for connecting the product to the mains electricity, its commissioning and maintenance must be carried out exclusively by a qualified and expert technician.



In order to avoid any danger from inadvertent resetting of the thermal cut-off device, this appliance must not be powered through an external switching device, such as a timer, or connected to a supply that is regularly powered or switched off by the circuit.

WARNING! Please abide by the following warnings:

- Before commencing the installation, check the "Product technical specifications", in particular whether this product is suitable for automating your guided part. Should it not be suitable, do NOT proceed with the installation.
- The product cannot be used before it has been commissioned as specified in the "Testing and commissioning" chapter.
- Before proceeding with the product's installation, check that all the materials are in good working order and suited to the intended applications.
- The product is not intended for use by persons (including children) with reduced physical, sensory or mental capacities, nor by anyone lacking sufficient experience or familiarity with the product.
- Children must not play with the appliance.
- Do not allow children to play with the product's control devices. Keep the remote controls out of reach of children.
- The system's power supply network must include a disconnection device (not supplied) with a contact opening gap permitting complete disconnection under the conditions envisaged by Overvoltage Category III.
- Handle the product with care during installation, taking care to avoid crushing, denting or dropping it, or allowing contact with liquids of any kind. Keep the product away from sources of heat and naked flames. Failure to observe the above can damage the product, and increase the risk of danger or malfunction. Should this happen, stop installation immediately and contact Customer Service.

- The manufacturer declines all liability for damages to property, objects or people resulting from failure to observe the assembly instructions. In such cases, the warranty for material defects shall not apply.
- The weighted sound pressure level of the emission A is lower than 70 dB(A).
- Cleaning and maintenance reserved for the user must not be carried out by unsupervised children.
- Before intervening on the system (maintenance, cleaning), always disconnect the product from the mains power supply and from any batteries.

- Inspect the system frequently, in particular the cables, springs and supports to detect any imbalances and signs of wear or damage. Do not use the product if it needs to be repaired or adjusted, because defective installation or incorrect balancing of the automation can lead to injuries.
- The packing materials of the product must be disposed of in compliance with local regulations.

2 PRODUCT DESCRIPTION AND INTENDED USE

MC800 is an electronic control unit for automating swing gates. The control unit is specially configured for being connected to devices belonging to the Opera System and to the Bluebus system. Other available accessories include receivers configured with “SM” connector.

This product complies with the criteria envisaged in the “Stand-By” regulation. The product enters the Stand-By mode 5 minutes after the end of a manoeuvre that terminated correctly. If the product is not configured, it goes into Standby mode after 10 minutes.

⚠ CAUTION! – Any use other than that specified herein or in environmental conditions other than those stated in this manual is to be considered improper and is strictly forbidden!

2.1 LIST OF CONTROL UNIT PARTS

The control unit consists of an electronic command and control board housed and protected in the box. **“Figure 1”** shows the main parts making up the board.

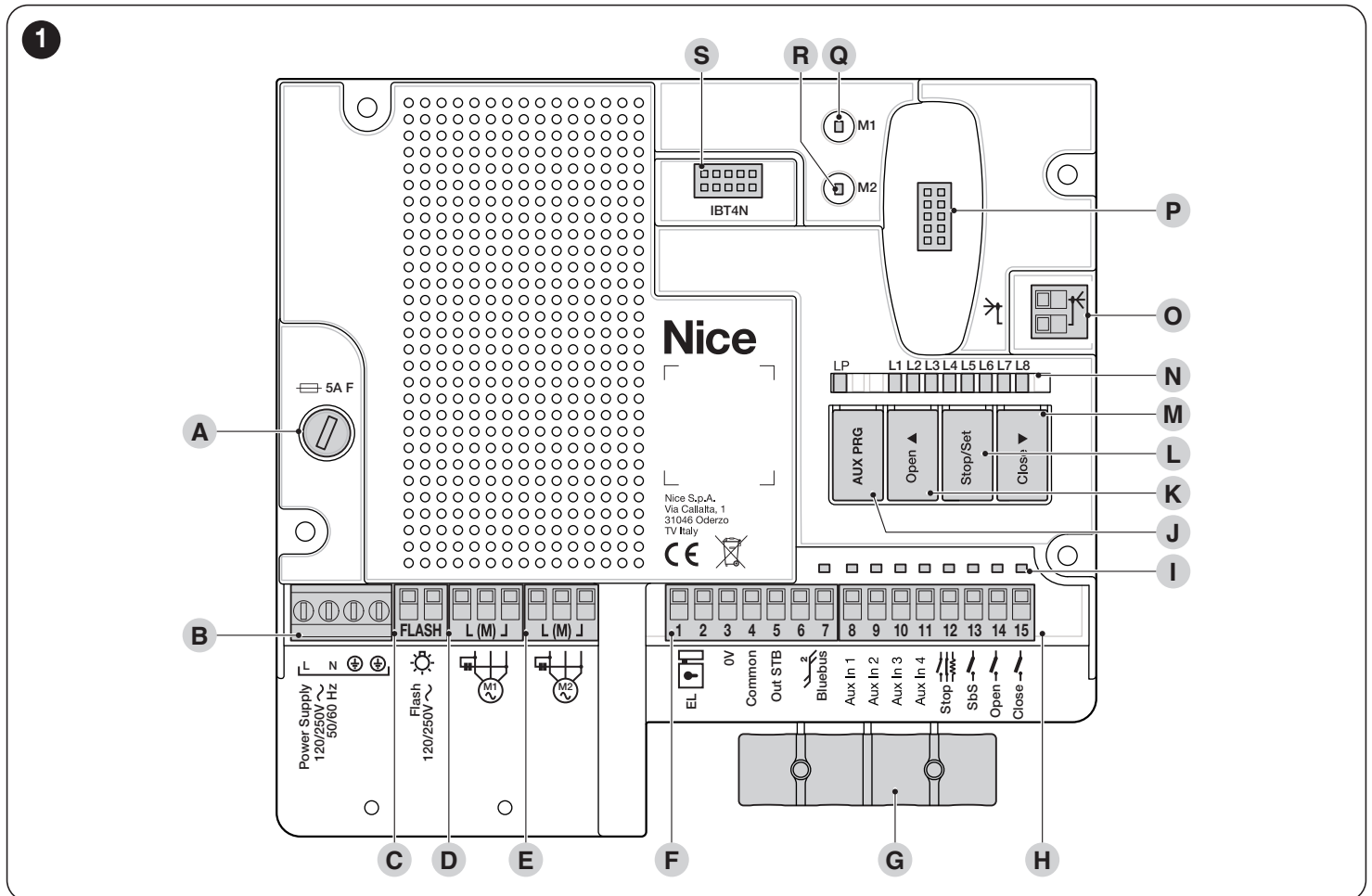

- A** Protection fuse (5A F)
- B** Mains power inputs terminal
- C** FLASH output terminal (120/250V)
- D** Motor 1 output terminal
- E** Motor 2 output terminal
- F** OUTPUTS terminal block (low-voltage)
- G** Cable clamps for fastening the power connections
- H** INPUTS terminal block (low-voltage)
- I** Inputs/outputs status LEDs
- J** Button for operation with relay photocells

- K** “Open” command and control unit programming button
- L** “Stop/Set” command and control unit programming button
- M** “Close” command and control unit programming button
- N** Control unit status visualisation LED
- O** Radio antenna terminal (accessory)
- P** “SM” quick connector for radio receiver (accessory)
- Q** Motor M1 status LED
- R** Motor M2 status LED
- S** IBT4N interface connector (accessory)

3 INSTALLATION

3.1 PRE-INSTALLATION CHECKS

Before proceeding with the product's installation, it is necessary to:

- check the integrity of the supply
- check that all the materials are in good working order and suited to the intended use
- check that all operating conditions comply with that specified in the "**Product usage limits**" paragraph and in the "**TECHNICAL SPECIFICATIONS**" chapter
- check that the chosen installation location is compatible with the product's overall dimensions (see "**Figure 2**")
- check that the surface chosen for installing the product is solid and can ensure stable attachment
- make sure that the installation area is not subject to flooding; if necessary, the product must be installed appropriately raised above ground level
- check that the space around the product allows safe and easy access
- check that all electrical cables to be used belong to the type listed in "**Table 1**"
- check that the automation has mechanical stops in both the opening and closing phases.

3.2 PRODUCT USAGE LIMITS

The product must be used exclusively with 120/250 V~ 50/60 Hz gearmotors of suitable power, with or without limit switch and equipped with integrated thermal cut-off.



The automation made by using MC800 must have sensitive edges.



Use a suitable sensitive edge capable of passing the "impact test" in any operating condition of the automation.

3.3 PRODUCT IDENTIFICATION AND OVERALL DIMENSIONS

The overall dimensions and label (A) that allow for identifying the product are shown in "**Figure 2**".

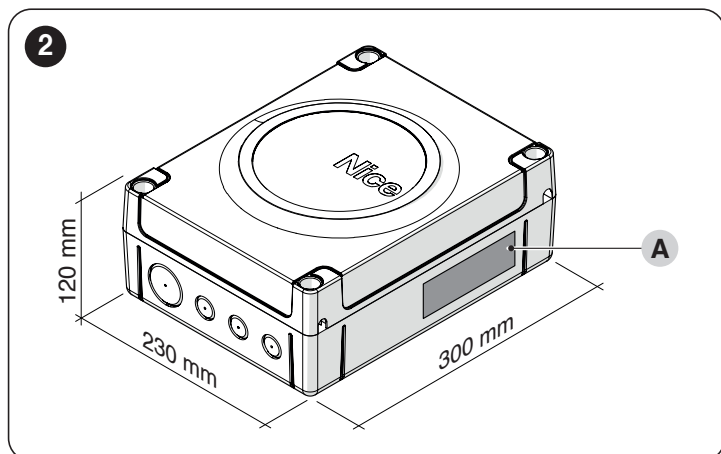

3.4 TYPICAL INSTALLATION

"**Figure 3**" shows an example of an automation system constructed using Nice components.

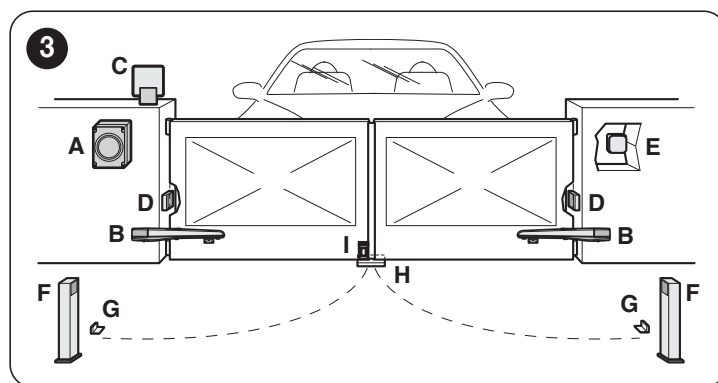

- A Control unit
- B Gearmotor
- C Warning light
- D Photocell
- E Digital keypad - Transponder reader - Key selector
- F Photocell column
- G Mechanical stops for the open position
- H Mechanical stop at closed position
- I Electric lock

These above-mentioned components are positioned according to a typical standard layout. Using the layout in "**Figure 4**" as a reference, define the approximate position in which each component of the system will be installed.



Before proceeding with the installation, prepare the required electrical cables by referring to "**Figure 4**" and to that stated in the "**TECHNICAL SPECIFICATIONS**" chapter.

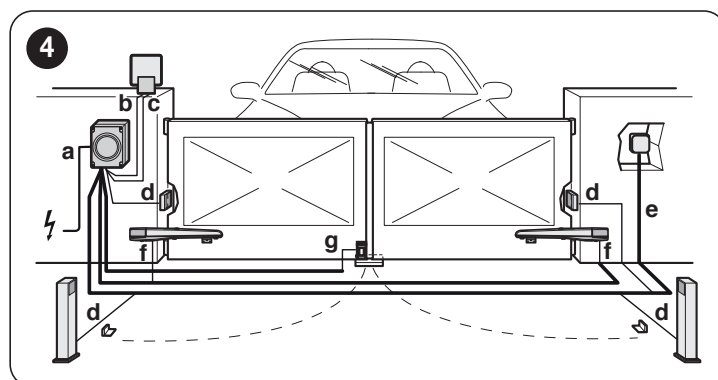

Table 1

TECHNICAL SPECIFICATIONS OF ELECTRICAL CABLES	
Identification no.	Cable characteristics
a	CONTROL UNIT POWER SUPPLY cable 1 cable 3 x 1.5 mm ² Maximum length 30 m [note 1]
b	WARNING LIGHT cable 1 cable 2 x 1.5 mm ² Maximum length 20 m
c	ANTENNA cable 1 x RG58-type shielded cable Maximum length 20 m; recommended < 5 m
d	BLUEBUS DEVICES cable 1 cable 2 x 0.5 mm ² Maximum length 20 m [note 2]
e	KEY SELECTOR cable 2 cables 2 x 0.5 mm ² Maximum length 50 m
f	MOTOR POWER SUPPLY cable 1 cable 4 x 1.5 mm ² Maximum length 10 m

TECHNICAL SPECIFICATIONS OF ELECTRICAL CABLES

Identification no.	Cable characteristics
g	ELECTRIC LOCK CONNECTION cable 1 cable 2 x 1 mm ² Maximum length 10 m

Note 1 If the power supply cable is longer than 30 m, a cable with larger cross-sectional area (3 x 2.5 mm²) must be used and a safety earthing system must be installed near the automation.

Note 2 If the BlueBus cable is longer than 20 m, up to maximum 40 m, a cable with larger gauge (2 x 1 mm²) must be used.



The cables used must be suited to the type of environment of the installation site.



When laying the ducting for routing the electrical cables and for the cable entry point into the control unit housing, check that there are no water deposits in the junction wells nor condensate in the connection ducts, as water and damp conditions could damage the product's electronic circuits.

3.5 INSTALLING THE CONTROL UNIT

To secure the control unit ("Figure 5" and "Figure 6"):

- loosen the screws (A) and remove the cover (B) of the control unit
- identify the pre-cut holes (C) located along the lower side of the box and perforate the ones used to pass the electrical cables



If necessary, the side cable entry can be used (D). In this case, suitable tube fittings must be used.

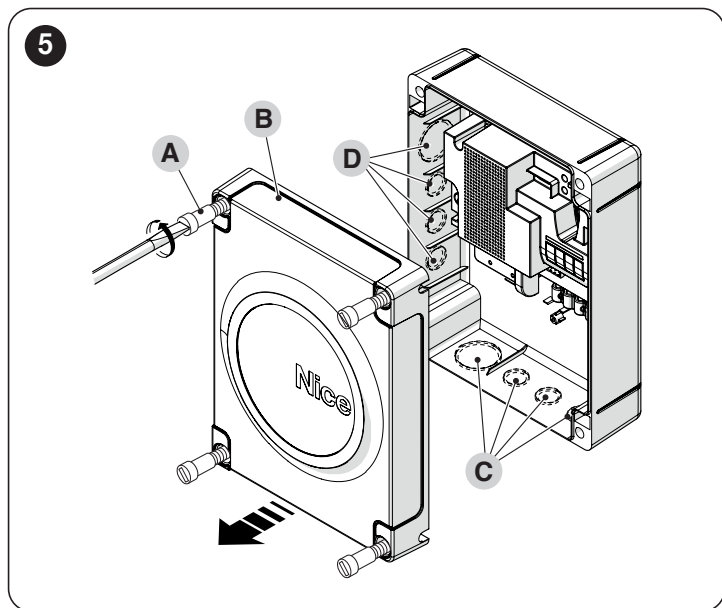

- drill the wall (E) by observing the measurements shown in the figure and arrange suitable wall plugs (not supplied)
- position the box (F) and fasten it with the screws (G) (not supplied)
- arrange cable glands for passing the connecting cables
- make the electrical connections by operating as described in the "ELECTRICAL CONNECTIONS" chapter.



To install any other devices used on the automated system, refer to the respective instruction manuals.

- after making the electrical connections, put the cover (B) back on and tighten the screws (A).

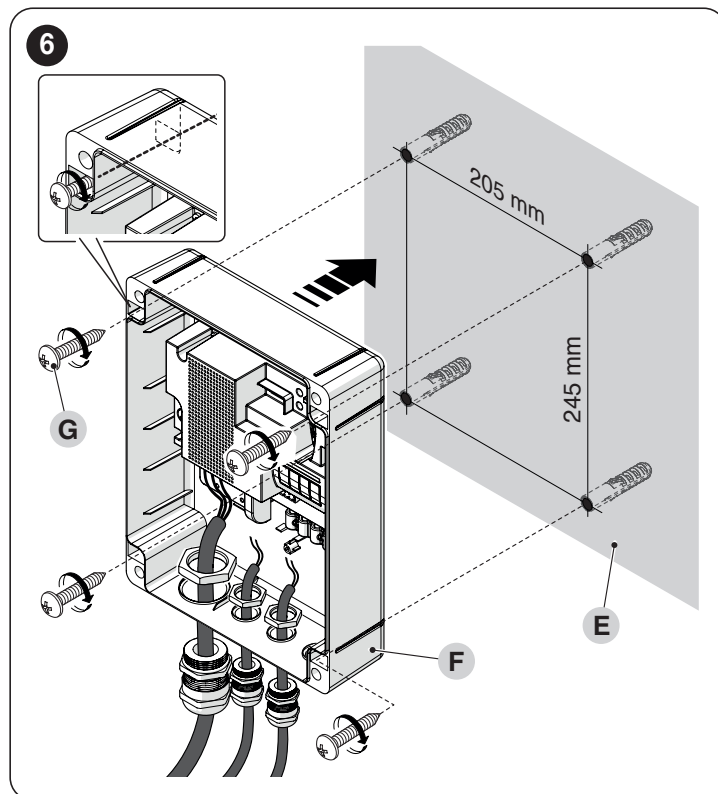

4 ELECTRICAL CONNECTIONS

4.1 PRELIMINARY CHECKS

The electrical connection of the various devices present on the automation (photocells, digital keypads, transponder card readers, etc.) to the control unit must be made through the Nice "Bluebus" system. For the other connections, refer to that specified below.



All electrical connections must be made with the system disconnected from the mains electricity and with the emergency power supply (if present in the automation) disconnected.



The connection operations must only be carried out by qualified personnel.



Mount a device on the electric power line that completely disconnects the automation from the grid.

- The disconnection device must have contacts with a sufficient gap to ensure complete disconnection, under the Category III overvoltage conditions, in accordance with the installation instructions. If necessary, this device guarantees quick and safe disconnection from the mains power and therefore must be positioned in sight of the automation. If located in a concealed position, it must be equipped with a system that prevents inadvertent or unauthorised reconnection of power, to avoid potential hazards.

4.2 WIRING DIAGRAM AND DESCRIPTION OF CONNECTIONS

4.2.1 CONNECTION DIAGRAM WITH RELAY AND BLUEBUS PHOTOCELLS IN STANDBY MODE

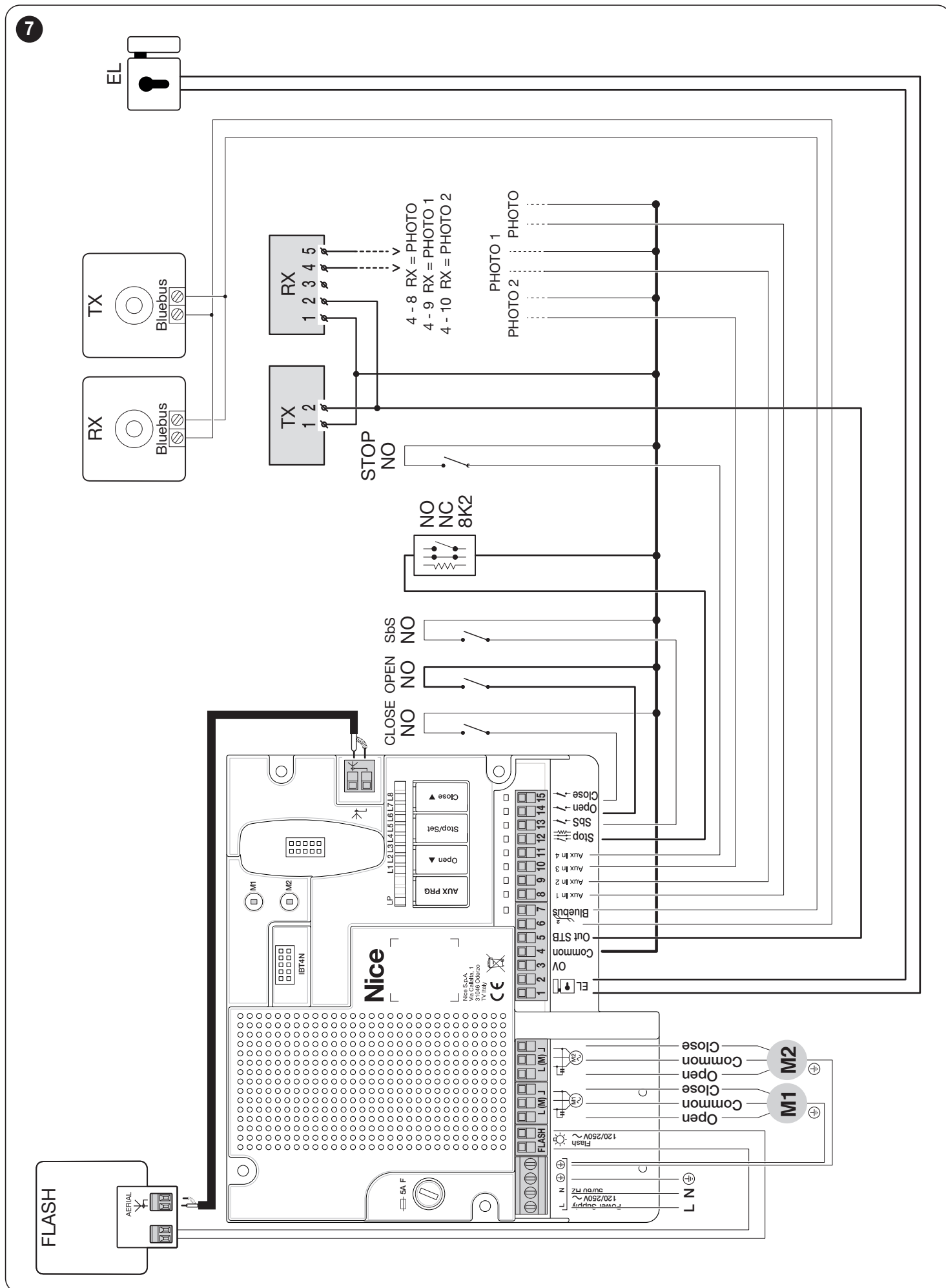

4.2.2 CONNECTION DIAGRAM WITH BLUEBUS PHOTOCELLS AND MOTOR LIMIT SWITCHES

8

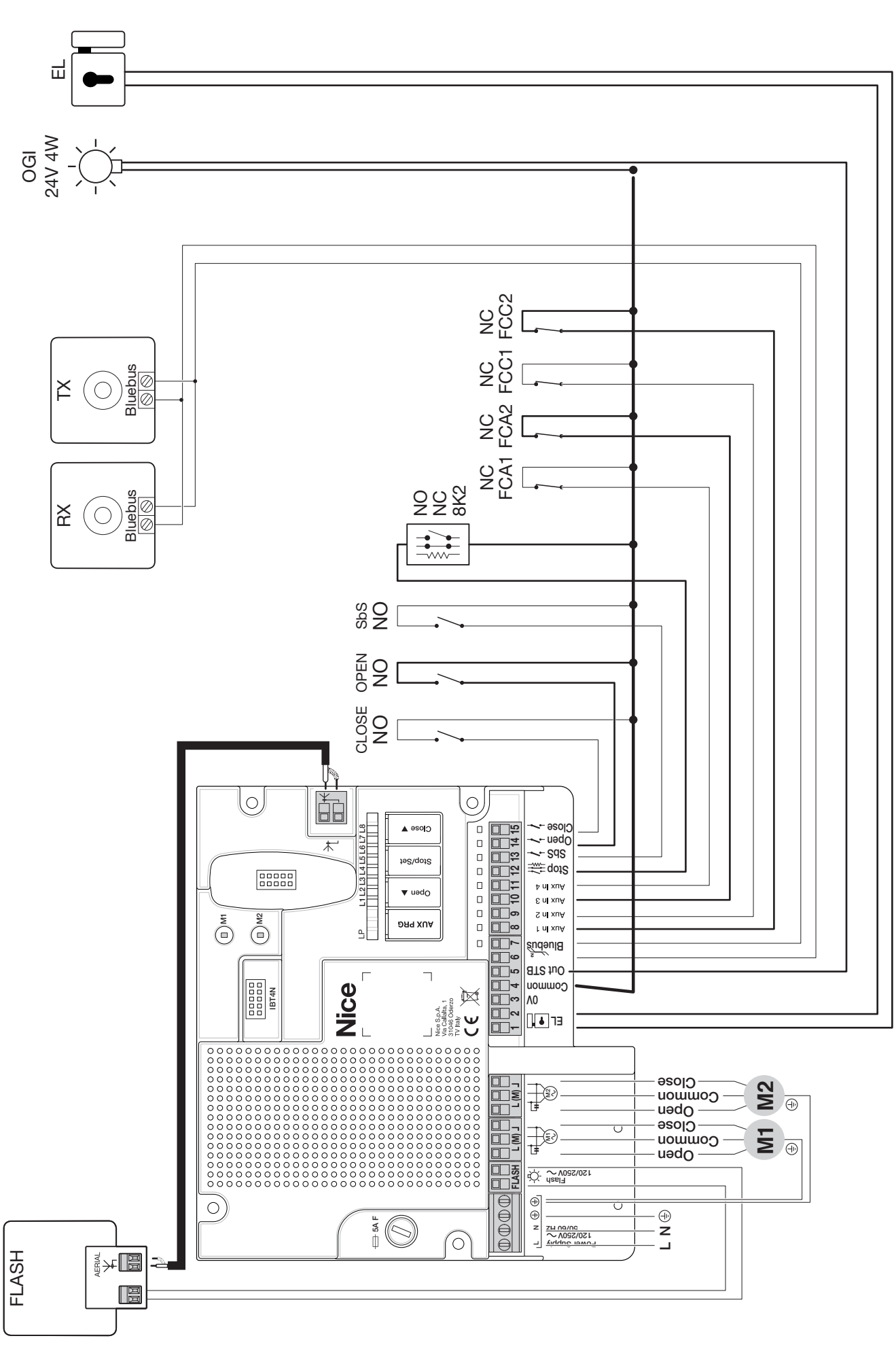

4.2.3 CONNECTION DIAGRAM WITH RELAY AND BLUEBUS PHOTOCELLS WITHOUT PHOTOTEST (STANDBY MODE DEACTIVATED)

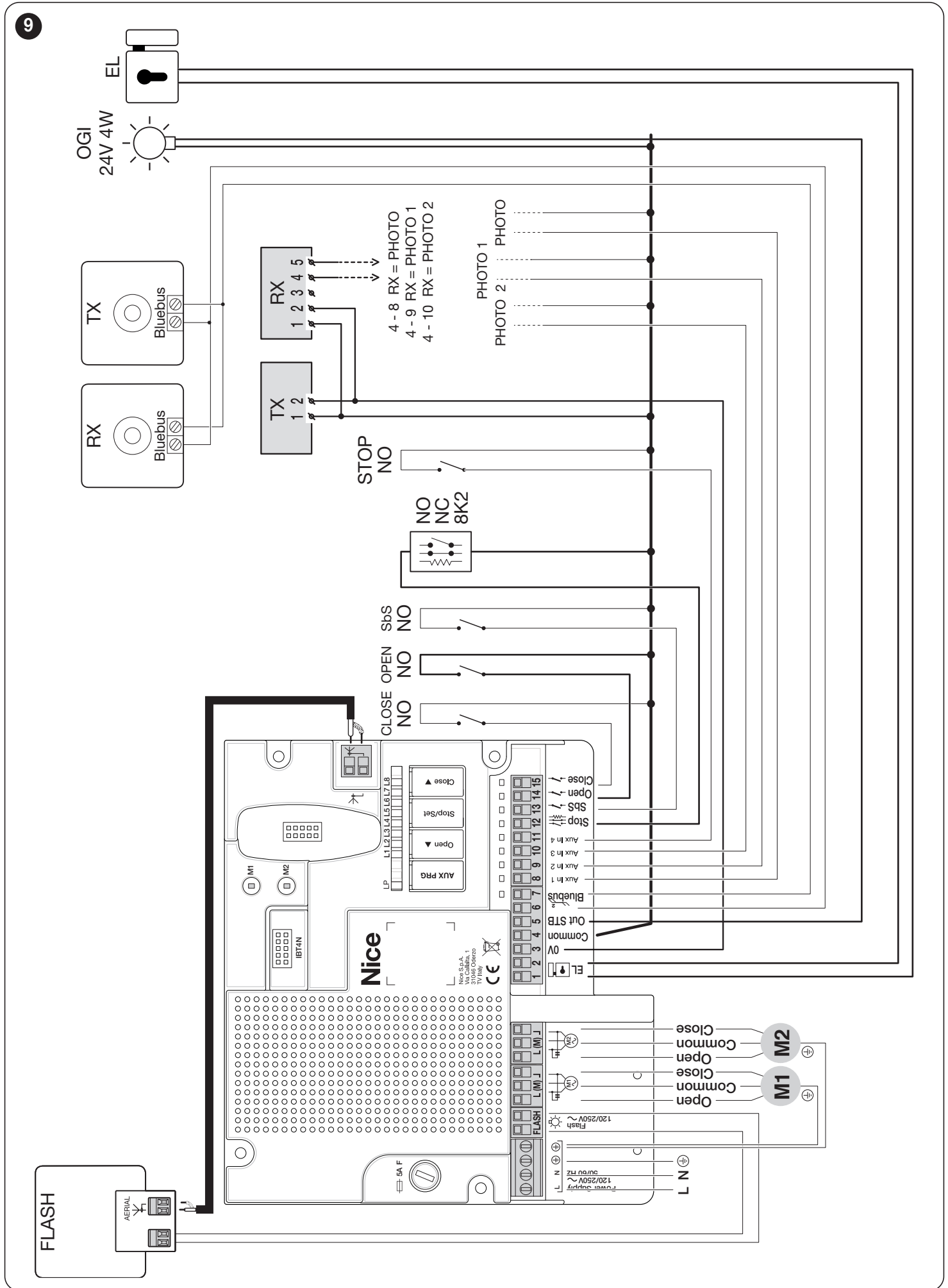

4.2.4 CONNECTION DIAGRAM WITH RELAY PHOTOCELLS WITH PHOTOTEST (STANDBY MODE DEACTIVATED)

10

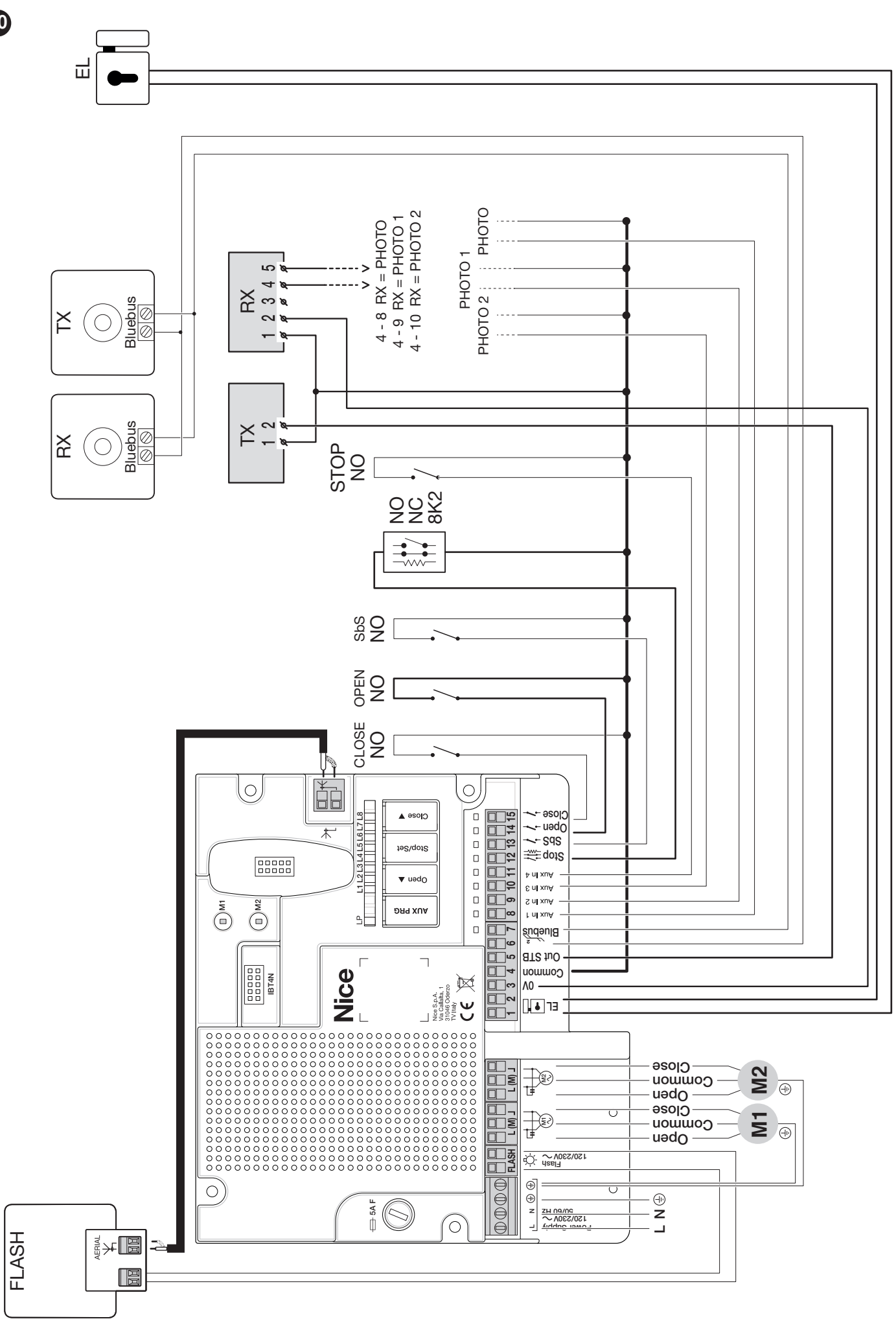

4.2.5 DESCRIPTION OF CONNECTIONS

The meaning of the codes/wording stamped on the electronic board near the relative terminals is described below.

Table 2

ELECTRICAL CONNECTIONS			
Terminals	Function	Description	Cable type
L - N - ⊕	Power supply 120/250V~ 50/60Hz	Mains power supply	3 x 1.5 mm ²
FLASH	Flashing output 120/250V~ 50/60Hz	Output for a 120/250V self-lamp (max. 21 W). The output can be programmed as 'courtesy light' (see section " Level 1 programming (ON-OFF) ")	Warning light: 2 x 1.5 mm ² Antenna: 1 x RG58-type shielded cable
L (M) J	Motor 1	Connection of motor M1	4 x 1.5 mm ²
L (M) J	Motor 2	Connection of motor M2	4 x 1.5 mm ²
1 - 2	Electric lock	Output for 12 V~ (maximum 15 VA) electric lock	2 x 1.0 mm ²
3	0 V	0 V power supply for services	1 x 0.5 mm ²
4	Common 24 V	Common for all inputs (+24 V==)	1 x 0.5 mm ²
5	Out STB	24 V output for relay photocell power supply, see (" Figure 7 "). Maximum power consumption: 4W. The output turns off in standby.	1 x 0.5 mm ²
6 - 7	BlueBus	Input for compatible devices (MOFB, MOFOB, MOB and MOTB). The devices must be connected in parallel through two conductors carrying both the power supply and the communication signals. It is not necessary to observe the pole markings. During the learning function, each device connected to the control unit will be individually recognised thanks to a univocal code. Whenever a device is added or eliminated, the control unit must run the learning procedure (see " Learning of connected devices " paragraph).	2 x 0.5 mm ²
8	AuxIn1	Input for motor 1 limit switch in fully open position (if not used, leave the input free) Photo input if programmed for relay photocells (refer to the " Programming with AUX inputs " paragraph).	1 x 0.5 mm ²
9	AuxIn2	Input for motor 2 limit switch in fully open position (if not used, leave the input free) Photo1 input if programmed for relay photocells (refer to the " Programming with AUX inputs " paragraph).	1 x 0.5 mm ²
10	AuxIn3	Input for motor 1 limit switch in fully closed position (if not used, leave the input free) Photo2 input if programmed for relay photocells (refer to the " Programming with AUX inputs " paragraph).	1 x 0.5 mm ²
11	AuxIn4	Input for motor limit switch 2 in full closure (if not used, leave input free). When used in photocell mode, the input becomes a STOP command.	1 x 0.5 mm ²
12	Stop	Input for devices that through their intervention trigger the immediate stoppage of the current manoeuvre followed by a brief reversal. NO (normally open) contacts, NC (normally closed) contacts or devices with 8.2 kΩ fixed resistor output, such as sensitive edges, can be connected to this input. Each device connected to this input will be individually recognised by the control unit during the learning phase (see " Learning of connected devices " paragraph). During this phase, if the control unit detects any variation with respect to the learned status, it triggers a STOP. One or more devices, even different from one another, can be connected to this input: any number of NO inputs in parallel; any number of NC inputs in series; 2 devices with 8.2 kΩ fixed resistor output in parallel. If there are more than 2 devices, they must all be connected in cascade mode with a single 8.2 kΩ terminating resistor; 2 NO and NC devices in parallel, putting an 8.2 kΩ resistor in series with the NC contact (this also allows for combining 3 devices: NO, NC and 8.2 kΩ).	1 x 0.5 mm ²
13	Step-by-step	Input for a NO (normally open) button, for sending commands in step-by-step mode.	1 x 0.5 mm ²
14	Open	Input for command devices that trigger the opening manoeuvre only, when they intervene. NO (normally open) contacts can be connected to this input.	1 x 0.5 mm ²
15	Close	Input for command devices that trigger the closing manoeuvre only, when they intervene. NO (normally open) contacts can be connected to this input.	1 x 0.5 mm ²

This product has a 24V output for supplying auxiliary devices and a connector for accessories.

The power consumption of accessories has not been taken into account in the calculation of consumption in standby mode. Check the respective instructions for the consumption of added devices.

4.2.6 OPERATIONS FOR CONNECTION

To make the electrical connections ("Figure 8"):

1. remove the terminals from their housings
2. connect the various devices to the relevant terminals according to the diagram shown in "Figure 8"
3. put the terminals back into their housings.



If the system includes a single gearmotor only, connect it to terminal M2 and leave terminal M1 free.

4.2.7 POSITIONING THE SAFETY CABLE CLAMP

Once the connections to the control unit have been made, the cables of the power connections must be secured with the relevant cable clamp ("Figure 11").

To do this:

1. remove the cable clamp (A) from its original position
2. place the cable clamp (A) over the connection cables to be secured and fasten it with the two screws (B).

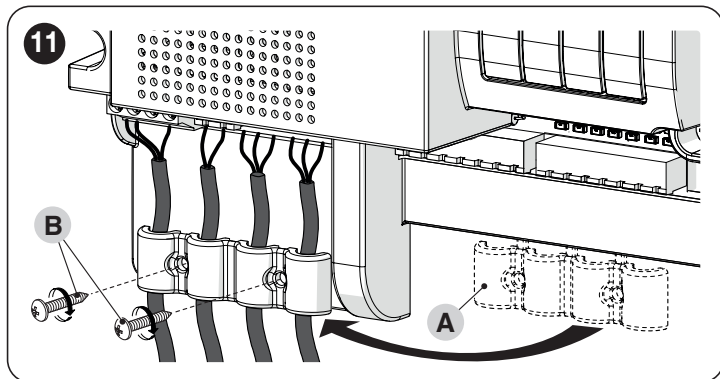

4.3 CONNECTING OTHER DEVICES TO THE CONTROL UNIT

In any additional devices belonging to the system (e.g. transponder card reader, light for the key selector, etc.) must be powered, they can be connected to the control unit using terminals "3 - 0 V" and "4 - Common" ("Figure 8"). The power supply voltage is 24 V₌₌ with a maximum available current of 200 mA.

4.4 ADDRESSING OF DEVICES CONNECTED WITH THE BLUEBUS SYSTEM

To allow the control unit to recognise the devices connected through the "BlueBUS" system, these devices must be addressed.

This operation can be carried out by correctly positioning the electrical jumper present in each device (also refer to the instruction manual of each device). Shown below is an addressing diagram for photocells, based on their type.

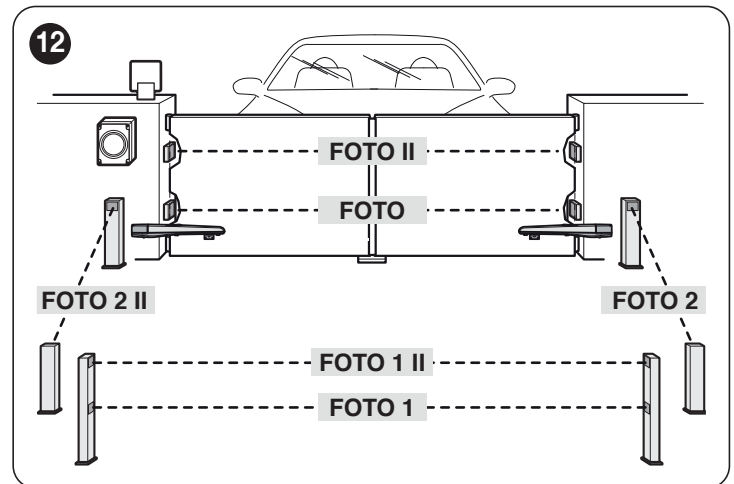

Table 3

PHOTOCELL ADDRESSES	
Photocell	Position of the jumpers
FOTO (PHOTO) External photocell h = 50 activated during the closing phase (stops and reverses the gate's movement)	
FOTO II (PHOTO II) External photocell h = 100 activated during the closing phase (stops and reverses the gate's movement)	
FOTO 1 (PHOTO 1) Internal photocell h = 50 cm with activation both during closing (stops and reverses the movement) and during opening (stops and restarts when the photocell disengages)	
FOTO 1 II (PHOTO 1 II) Internal photocell h = 100 cm with activation both during closing (stops and reverses the movement) and during opening (stops and restarts when the photocell disengages)	
FOTO 2 (PHOTO 2) Internal photocell triggered during the opening phase (stops and reverses the gate's movement)	
FOTO 2 II (PHOTO 2 II) Internal photocell triggered during the opening phase (stops and reverses the gate's movement)	
FOTO 3 (PHOTO 3) CONFIGURATION NOT ALLOWED	



At the end of the installation procedure, or after photocells or other devices have been removed, it is necessary to complete the learning procedure (see the "Learning of connected devices" paragraph).

4.5 INITIAL START-UP AND ELECTRICAL CONNECTIONS TEST

After powering the control unit, carry out the following checks (**"Figure 13"**):

1. after a few seconds, check that the **"Bluebus" (A)** LED flashes regularly with one flash per second
2. check that the LEDs of the photocells, both TX (transmission) and RX (reception), flash. The type of flash emitted in this phase is not significant
3. check that the warning light connected to the **"Flash"** output is turned off.

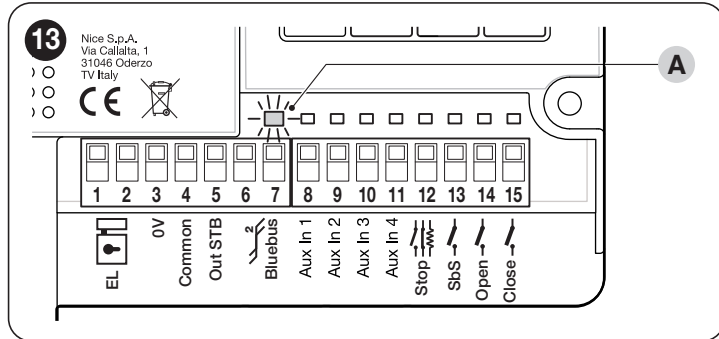

! If any one of these tests fails, disconnect the power supply to the control unit and check the various electrical connections made previously.

4.5.1 PROGRAMMING AND VERIFICATION OF STANDBY MODE

If, when switched on, the eight LEDs (L1..L8) make three flashes, standby is active. To activate or deactivate the standby mode, all three buttons (Open/Stop/Close) must be held down, the LEDs L1..L8 start flashing and the buttons must be released during the third flash. If standby mode is activated, all leds L1..L8 will flash three times. If standby is switched off, there will be no flashing.

4.5.2 PROGRAMMING WITH AUX INPUTS

As an alternative to photocells with relays, it is possible to connect motor limit switches to the control unit on inputs AUX 1 (FCA1), AUX 2 (FCA2), AUX 3 (FCC1) and AUX 4 (FCC2). For this function it will be necessary to activate **"Programming AUX inputs"**.

To do this:

- press and hold the **Aux PRG** button until the 'LP' LED goes out.

! Any inputs not used must be kept free.

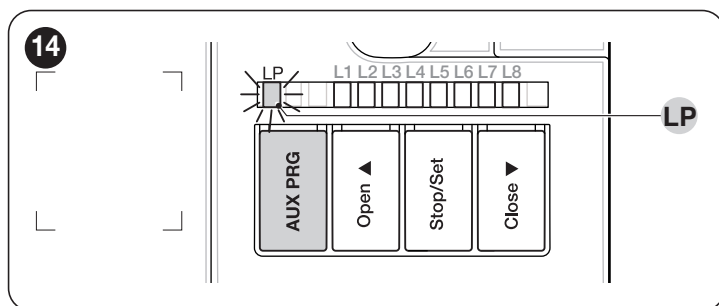

To deactivate the **"Programming AUX inputs"** function, press the **Aux PRG** button until the "LP" LED goes out.

! If the **"Photocell programming"** function is activated (**"LP"** LED lit), inputs AuxIn1, AuxIn2, AuxIn3, AuxIn4 cannot be used as limit switches.

For further details on the operation with and without the phototest, consult the wiring diagrams under the **"Connection diagram with relay and Bluebus photocells without phototest (standby mode deactivated)"** and **"Connection diagram with relay photocells with phototest (standby mode deactivated)"** paragraphs.

4.6 LEARNING OF CONNECTED DEVICES

After the initial start-up, the control unit must recognise the devices connected to the **"Bluebus"** and **"Stop"** inputs.

! The control unit automatically learns the relay photocells connected to inputs AUX1, AUX2 and AUX3, unless the function of the inputs has been changed to use the motor limit switches.

! The learning phase must be carried out even if no device is connected to the control unit.

The control unit can individually recognise the various devices connected, thanks to the learning procedure, and detect possible anomalies.

For this to occur, the device learning procedure must be carried out whenever a device is added or removed.

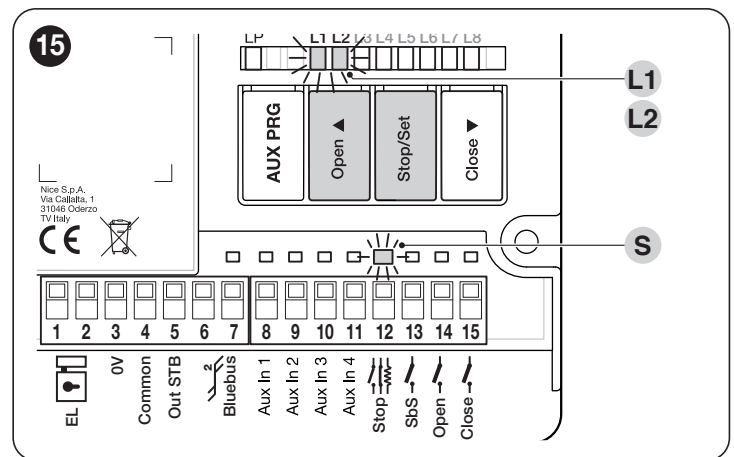

LEDs **"L1"** and **"L2"** on the control unit (**"Figure 15"**) emit some slow flashes to signal that the learning procedure must be carried out.

To do this:

1. simultaneously press and hold the **[Open ▲]** and **[Stop/Set]** buttons
2. release the buttons when LEDs **"L1"** and **"L2"** start flashing quickly (after roughly 3 seconds)
3. wait a few seconds until the control unit has completed the device learning phase
4. once this phase terminates, the **"Stop" (S)** LED must be lit and LEDs **"L1"** and **"L2"** must switch off (LEDs **"L3"** and **"L4"** could start flashing).

! If the AUX In 1-2-3 inputs are used to connect the relay photocells, leave any inputs not used free.

4.7 SELECTING THE TYPE OF MOTOR (FOR HYDRAULIC MOTORS ONLY)

! This phase must only be carried out if hydraulic motors are connected to the control unit.

In hydraulic actuators, the thrust to keep the gate closed is generated within a hydraulic circuit that remains constantly under pressure. When time and wear reduce the hydraulic circuit's tightness, after a few hours it may occur that the internal pressure decreases, potentially causing the gate leaves to open slightly. To overcome this problem, the control unit has a **"Pressure maintenance"** function that, if activated, every 4 hours that the gate has been closed triggers a brief "close" command in order to fully close the leaves and reload the pressure of the hydraulic circuit. To activate the function, refer to the **"Level 1 programming (ON-OFF)"** - Function L8" paragraph.

4.8 LEARNING OF THE MECHANICAL STOP POSITIONS

Once the connected devices have been learned, the mechanical stop positions must be learned (maximum opening and maximum closing). This procedure can be carried out in three different ways: **automatic**, **manual** and **mixed**.

In **automatic** mode, the control unit learns the mechanical stops, calculates the most appropriate gate leaf offsets and calculates the slowdown points "A" ("Figure 16").



Before starting the self-learning procedure in automatic mode, verify that the motor force is suited to the type of motor being used (see paragraph "Level 2 programming (adjustable parameters) - Function L6").

In **manual** mode, the positions ("Figure 16") are programmed one-by-one, by moving the leaves to the desired points. The position to be programmed can be identified when one of the eight LEDs "L1...L8" flashes (see "Table 4").

In the **mixed** mode, it is possible to run the automatic procedure then, using the manual procedure, modify one or more positions.

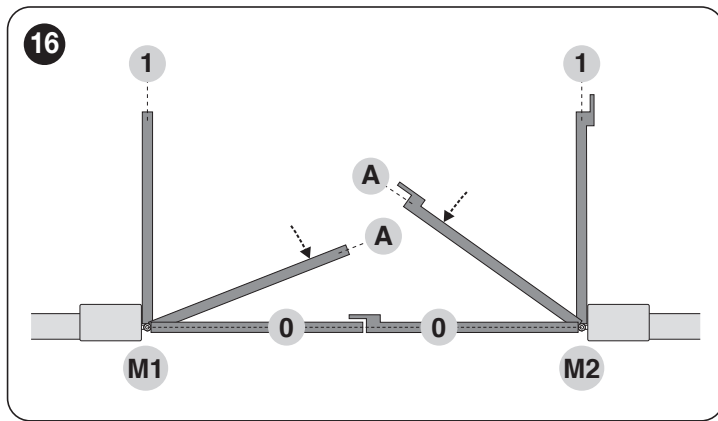

Table 4

PROGRAMMING POSITIONS		
Position	LED	Description
Position 0 (motor 1)	L1	maximum closing position: when the leaf relative to motor 1 strikes the closing mechanical stop
Position 0 (motor 2)	L2	maximum closing position: when the leaf relative to motor 2 strikes the closing mechanical stop
Position A (motor 2) Slowdown start	L5	Position after which the motor 2 closing speed will start decreasing until the leaf stops in position 0
Position A (motor 1) Slowdown start	L6	Position after which the motor 1 closing speed will start decreasing until the leaf stops in position 0
Position 1 (motor 2)	L7	Maximum opening position: when the leaf relative to motor 2 strikes the opening mechanical stop
Position 1 (motor 1)	L8	Maximum opening position: when the leaf relative to motor 1 strikes the opening mechanical stop



The "slowdown" configuration (LEDs "L5" and "L6") can be done "manually" after configuring the closing and opening positions.

4.8.1 LEARNING IN AUTOMATIC MODE

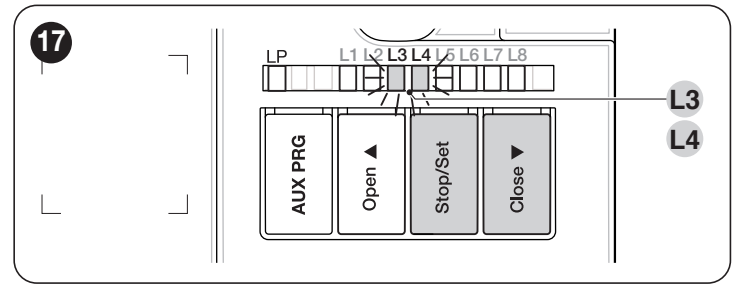

To effect the automatic learning procedure:

1. simultaneously press and hold the and [Stop/Set] buttons [Close ▼]
2. release the buttons when LEDs "L3" and "L4" start flashing quickly (after roughly 3 seconds)
3. check that the automation carries out the following manoeuvre sequences:
 - a. closing of motor M1 up to the mechanical stop
 - b. closing of motor M2 up to the mechanical stop
 - c. opening of motor M2 up to the mechanical stop
 - d. opening of motor M1 up to the mechanical stop
 - e. closing of motor M1 up to the mechanical stop
 - f. closing of motor M2 up to the mechanical stop.



If the first two manoeuvres (a and b) are not "closing" but "opening" manoeuvres, press the [Open ▲] or [Close ▼] button to stop the learning phase. At this point, invert the control wires (external positions with respect to the terminal) on the motor that executed the opening manoeuvre and repeat the self-learning procedure.

4. at the end of the closing manoeuvre (e-f) of the two motors, LEDs "L3" and "L4" switch off to indicate that the procedure was carried out correctly.



If, during the automatic learning procedure, the photocells or one of the devices connected to the "stop" input intervene, the procedure interrupts and LED L1 starts flashing. In this case, the self-learning procedure must be repeated from the beginning.



The automatic learning procedure can be run again at any time, even after the installation phase; for example, after modifying the position of the mechanical stops.

4.8.2 LEARNING IN MANUAL MODE



The user has maximum 10 seconds to press the buttons consecutively during the learning procedure. After this time, the procedure terminates automatically and memorises the changes made up to that time.

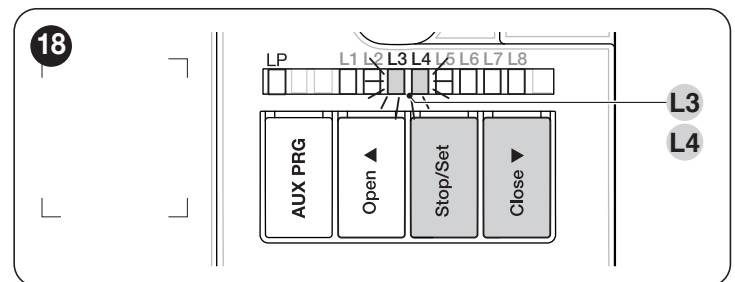

To effect the manual learning procedure:

1. simultaneously press and hold the and [Stop/Set] buttons [Close ▼]

2. release the buttons when LEDs "L3" and "L4" start flashing quickly (after roughly 3 seconds)
3. press [**Stop/Set**]
4. LED "L1" flashes: **position 0 of M1**
 - to command and bring motor 1 to **position "0"** ("Figure 16"): press and hold the [**Open ▲**] o [**Close ▼**] button. Once this position is reached, release the button to stop the manoeuvre
 - to memorise the position, press and hold the [**Stop/Set**] button for at least 3 seconds then release it (after 2 seconds LED "L1" will remain lit and after the [**Stop/Set**] button is released, LED "L2" will start flashing)
5. LED "L2" flashes: **position 0 of M2**
 - to command and bring motor 2 to **position "0"** ("Figure 16"): press and hold the [**Open ▲**] o [**Close ▼**] button. Once this position is reached, release the button to stop the manoeuvre
 - to memorise the position, press and hold the [**Stop/Set**] button for at least 3 seconds then release it (after 2 seconds LED "L2" will remain lit and after the [**Stop/Set**] button is released, LED "L5" will start flashing)
6. LED "L5" flashes: **position A of M2** (configurable only after tyhe opening position is acquired)
 - to command and bring motor 2 to **position "A"** ("Figure 16"): press and hold the [**Open ▲**] o [**Close ▼**] button. Once this position is reached, release the button to stop the manoeuvre
 - to memorise the position, press and hold the [**Stop/Set**] button for at least 3 seconds then release it (after 2 seconds LED "L5" will remain lit and after the [**Stop/Set**] button is released, LED "L6" will start flashing)
7. LED "L6" flashes: **position A of M1** (configurable only after tyhe opening position is acquired)
 - to command and bring motor 1 to **position "A"** ("Figure 16"): press and hold the [**Open ▲**] o [**Close ▼**] button. Once this position is reached, release the button to stop the manoeuvre
 - to memorise the position, press and hold the [**Stop/Set**] button for at least 3 seconds then release it (after 2 seconds LED "L6" will remain lit and after the [**Stop/Set**] button is released, LED "L7" will start flashing)
8. LED "L7" flashes: **position 1 of M2**
 - to command and bring motor 2 to **position "1"** ("Figure 16"): press and hold the [**Open ▲**] o [**Close ▼**] button. Once this position is reached, release the button to stop the manoeuvre
 - to memorise the position, press and hold the [**Stop/Set**] button for at least 3 seconds then release it (after 2 seconds LED "L7" will remain lit and after the [**Stop/Set**] button is released, LED "L8" will start flashing)
9. LED "L8" flashes: **position 1 of M1**
 - to command and bring motor 1 to **position "1"** ("Figure 16"): press and hold the [**Open ▲**] o [**Close ▼**] button. Once this position is reached, release the button to stop the manoeuvre
 - to memorise the position, press and hold the [**Stop/Set**] button for at least 3 seconds then release it (after 2 seconds LED "L8" will remain lit until the [**Stop/Set**] button is released).



When LEDs "L1..L8" flash, to shift between LEDs simply press the [**Open ▲**] or [**Close ▼**] button briefly (the LED will flash to signal the current position).



On systems with a single motor, programme the positions relative to motor 2 only: LEDs L2 (0 of M2), L5 (A of M2) and L7 (1 of M2).

4.8.3 LEARNING IN MIXED MODE



The user has maximum 10 seconds to press the buttons consecutively during the learning procedure. After this time, the procedure terminates automatically and memorises the changes made up to that time.

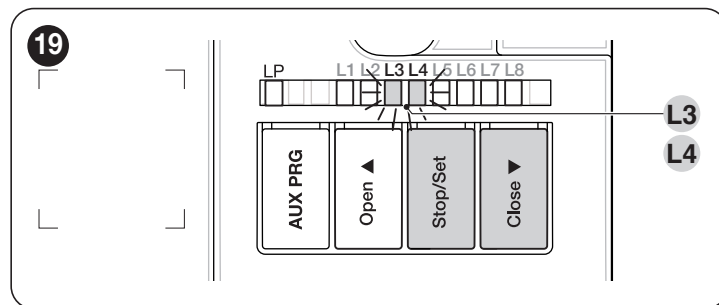

To effect the learning procedure in mixed mode:

1. run the self-learning procedure in automatic mode as described under the "**Learning in automatic mode**" paragraph
2. simultaneously press and hold the and [**Stop/Set**] buttons [**Close ▼**]
3. release the buttons when LED "L1" starts flashing
4. briefly press the [**Open ▲**] o [**Close ▼**] button to shift the flashing LED (L1...L8) to the position to be programmed
5. repeat this last operation for all the other positions to be modified.

4.9 CHECKING THE GATE MOVEMENT

At the end of the learning phase, we recommend letting the control unit run a few opening and closing manoeuvres to verify whether the gate moves correctly and if there are any assembly and adjustment defects.

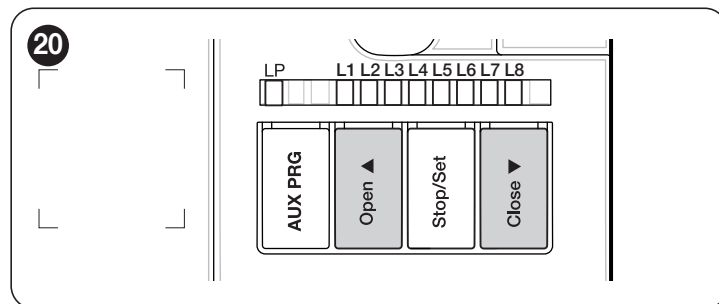

1. To do this:
2. press the [**Open ▲**] button ("Figure 20"). Check that the acceleration, constant-speed and slowdown phases are present during the opening manoeuvre. Once the manoeuvre terminates, the gate leaves must stop a few centimetres from the opening mechanical stop
3. press the [**Close ▼**] button ("Figure 20") and verify that the acceleration, constant-speed and slowdown phases are present during the closing manoeuvre. Once the manoeuvre terminates, the gate leaves must be perfectly closed on the closing mechanical stop
4. check that all the previously adjusted functions have been learned by the control unit.

5 TESTING AND COMMISSIONING

These are the most important phases of the automation's construction, as they ensure maximum safety of the system. The test can also be used to periodically verify the devices making up the automation.

 **Testing and commissioning of the automation must be performed by skilled and qualified personnel, who are responsible for the tests required to verify the solutions adopted according to the risks present, and for ensuring that all legal provisions, standards and regulations are met, in particular all the requirements of the EN 12453 standard, which defines the test methods for checking gate automations.**

The additional devices must undergo specific testing, both in terms of their functions and their proper interaction with the control unit. Refer to the instruction manuals of the individual devices.

5.1 TESTING

The sequence of steps to be performed when running the testing phase, as described below, refers to a typical system ("Figure 3").

To run the test:

1. verify that all the instructions stated in the "**GENERAL SAFETY WARNINGS AND PRECAUTIONS**" chapter (page 2) have been strictly observed
2. unlock the motors for the manual manoeuvre as described in the respective instruction manual. Move the gate manually and verify whether the leaves can be opened and closed with a force below 390 N
3. lock the motors as described in the respective instruction manual
4. using the control devices (transmitter, control button, key selector, etc.), test the gate's opening, closing and stoppage movements to make sure that the leaves move as intended. Several tests should be carried out to assess the movement of the leaves and detect any defects in the installation and adjustment, besides any points of excessive friction
5. verify the proper operation of all the safety devices present, one by one (photocells, sensitive edges, etc.). If a device intervenes, the "**Bluebus**" (A - "**Figure 13**") LED on the control unit will emit two quick flashes to confirm the recognition
6. if potentially dangerous situations due to the movement of the leaves have been prevented by limiting the impact force, the latter must be measured according to the EN 12445 standard and, if the "motor force" control is used to aid the system in reducing the impact force, it is necessary to test various adjustments to find the one that gives the best results.

5.2 COMMISSIONING



Commissioning can only be performed after all testing phases have been successfully completed.



Before commissioning the automation, ensure that the owner is properly informed of all residual risks and hazards.

To commission the automation:

1. compile the automation's technical file, which must include the following documents: overall drawing of the automation, wiring diagram, risk assessment and relative solutions adopted, the manufacturer's declaration of conformity for all devices used and the declaration of conformity compiled by the installer
2. affix a data plate on the gate specifying at least the following data: type of automation, name and address of the manufacturer (responsible for commissioning), serial number, year of manufacture and CE mark
3. compile the declaration of conformity of the automation and hand it to the owner of the automation
4. compile the User Manual of the automation and hand it to the owner of the automation
5. compile and provide the owner with the automation's "Maintenance schedule", containing the maintenance instructions for all the automation's devices.



For all the above-mentioned documentation, Nice – through its technical assistance service – provides the following: instruction manuals and guides.

6 PROGRAMMING

There are 3 buttons on the control unit: **[Open ▲]**, **[Stop/Set]** and **[Close ▼]** ("**Figure 21**") which can be used both for commanding the control unit during the testing phase and to programme the available functions.

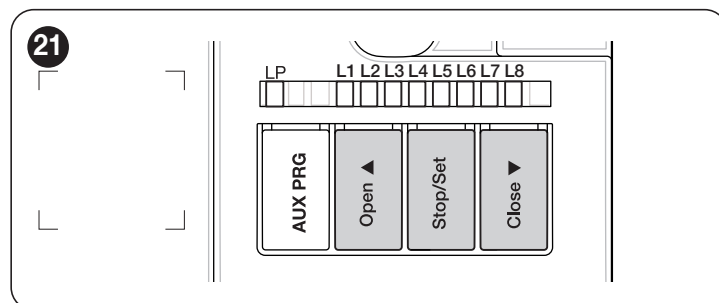

The available programmable functions are grouped into **two levels** and their operating status is signalled by eight LEDs "**L1 ... L8**" located on the control unit (LED lit = function enabled; LED off = function disabled).

6.1 USING THE PROGRAMMING BUTTONS

[Open ▲] Button for commanding the gate opening
Selection button during the programming phase.

[Stop/Set] Button used to stop a manoeuvre
If pressed for more than 5 seconds, it allows for entering the programming mode.

[Close ▼] Button for commanding the gate's closure
Selection button during the programming phase.

6.2 LEVEL 1 PROGRAMMING (ON-OFF)

All the Level 1 functions are factory-set to “OFF” and can be modified at any time. To check the various functions, refer to “Table 5”.

6.2.1 LEVEL 1 PROGRAMMING PROCEDURE



The user has maximum 20 seconds to press the buttons consecutively during the programming procedure. After this time, the procedure terminates automatically and memorises the changes made up to that time.

To perform Level 1 programming:

1. press and hold the [Stop/Set] button until LED “L1” starts flashing
2. release the [Stop/Set] button when LED “L1” starts flashing
3. press the [Open ▲] or [Close ▼] button to move the flashing LED to the LED associated with the function to be modified
4. press the [Stop/Set] button to change the status of the function:
 - short flash = OFF
 - long flash = ON
5. wait 10 seconds (maximum time) to exit the programming mode.



To set other functions to “ON” or “OFF”, while the procedure is running, repeat points 2 and 3 during the phase itself.

Table 5

LEVEL 1 FUNCTIONS (ON-OFF)		
LED	Function	Description
L1	Automatic closing	Function ENABLED: after an opening manoeuvre there is a pause (equal to the set pause time), after which the control unit automatically starts a closing manoeuvre. The pause time is set by default to 30 seconds. Function NOT ENABLED: the system works in “semi-automatic” mode.
L2	Close after photo	Function ENABLED: if the photocells intervene during the opening or closing manoeuvre, the pause time drops to 5 seconds regardless of the set “pause time”. With “automatic closing” disabled, if the photocells intervene during the opening or closing manoeuvre, the “automatic closing” activates with the set “pause time”.
L3	Always Close	Function ENABLED: in the event of a blackout, even of short duration, 10 seconds after the electricity is restored the control unit detects that the gate is open and automatically starts a closing manoeuvre, preceded by 5 seconds of pre-flashing. Function DISABLED: when the electricity is restored, the gate remains in the same position.
L4	Ramming function	Function ENABLED: before the opening manoeuvre starts (starting from the closed gate position), a brief closing manoeuvre is triggered to facilitate unlocking of the electric lock.
L5	Warning / Courtesy light	Function ACTIVE: the 'flashing' output (FLASH - 120/250V~ 50/60Hz) switches its operation to 'courtesy light'. Function NOT ENABLED: the output functions as a warning light.
L6	Pre-flashing	Function ENABLED: the warning light starts flashing 3 seconds before the start of the manoeuvre to signal in advance a dangerous situation. Function NOT ENABLED: the warning light starts flashing when the manoeuvre starts.
L7	“Close” becomes “Partial Open 1”	Function ENABLED: the “Close” input of the control unit switches its operation to “Partial Open 1”.
L8	Pressure maintenance	Function ENABLED: after 4 hours during which the gate has been permanently closed, a brief closing manoeuvre is triggered to reload the hydraulic circuit pressure.

6.3 LEVEL 2 PROGRAMMING (ADJUSTABLE PARAMETERS)

All the Level 2 parameters are factory-set as shown in the “GREY” sections in “Table 6” and can be modified at any time. The parameters can be set to a scale of 1 to 8. To check the value corresponding to each LED, refer to “Table 6”.

6.3.1 LEVEL 2 PROGRAMMING PROCEDURE



The user has maximum 20 seconds to press the buttons consecutively during the programming procedure. After this time, the procedure terminates automatically and memorises the changes made up to that time.

To perform Level 2 programming:

1. press and hold the [Stop/Set] button until LED “L1” starts flashing
2. release the [Stop/Set] button when LED “L1” starts flashing
3. press the [Open ▲] or [Close ▼] button to move the flashing LED to the “entry LED” associated with the parameter to be modified
4. press and hold the [Stop/Set] button. With the [Stop/Set] button pressed:
 - wait roughly 3 seconds, until the LED representing the current level of the parameter to be modified lights up
 - press the [Open ▲] or [Close ▼] button to shift the LED associated with the parameter's value
5. release the [Stop/Set] button
6. wait 10 seconds (maximum time) to exit the programming mode.



To set multiple parameters during the procedure's execution, repeat the operations from point 2 to point 4 during the phase itself.



The set value highlighted in grey ("Table 6") indicates that this value is the factory setting.

Table 6

LEVEL 2 FUNCTIONS (ADJUSTABLE PARAMETERS)				
Entry LED	Parameter	LED (level)	Set value	Description
L1	Pause Time	L1	5 seconds	Adjusts the pause time, in other words, the time that elapses before automatic re-closure. It is only effective if the Close function is enabled.
		L2	15 seconds	
		L3	30 seconds	
		L4	45 seconds	
		L5	60 seconds	
		L6	80 seconds	
		L7	120 seconds	
		L8	180 seconds	
L2	Step-by-Step function	L1	Open - Stop - Close - Stop	Controls the sequence of commands associated with the "SbS", "Open" and "Close" inputs or the radio control. Note: setting L4 , L5 , L7 and L8 , the behaviour of the "Open" and "Close" commands also changes.
		L2	Open - Stop - Close - Open	
		L3	Open - Close - Open - Close	
		L4	CONDOMINIUM During the opening manoeuvre , the "Step-by-Step" and "Open" commands do not cause any effect; instead the "Close" command causes the movement to reverse, namely the closing of the gate leaves. During the closing manoeuvre , the "Step-by-Step" and "Open" commands cause a reversal of the movement, namely the opening of the gate leaves; instead the "Close" command does not cause any effect.	
		L5	CONDOMINIUM 2 During the opening manoeuvre , the "Step-by-Step" and "Open" commands do not cause any effect; instead the "Close" command causes the movement to reverse, namely the closing of the gate leaves. <u>If the sent command remains for more than 2 seconds, a "Stop" command is executed.</u> During the closing manoeuvre , the "Step-by-Step" and "Open" commands cause a reversal of the movement, namely the opening of the gate leaves; instead the "Close" command does not cause any effect. <u>If the sent command remains for more than 2 seconds, a "Stop" command is executed.</u>	
		L6	STEP-BY-STEP 2 (less than 2 seconds causes partial opening)	
		L7	HOLD-TO-RUN The manoeuvre is only executed if the sent command remains; if the command is interrupted, the manoeuvre stops.	
		L8	"Semi-automatic" opening, "hold-to-run" closing.	
L3	Opening delay	L1	0 %	Adjusts the opening delay for the lower leaf motor: It can be programmed as a percentage of the work time.
		L2	10 %	
		L3	15 %	
		L4	20 %	
		L5	25 %	
		L6	30 %	
		L7	40 %	
		L8	50 %	
L4	Closing delay	L1	0 %	Adjusts the closing delay for the upper leaf motor. It can be programmed as a percentage of the work time.
		L2	10 %	
		L3	15 %	
		L4	20 %	
		L5	25 %	
		L6	30 %	
		L7	40 %	
		L8	50 %	

LEVEL 2 FUNCTIONS (ADJUSTABLE PARAMETERS)

Entry LED	Parameter	LED (level)	Set value	Description
L5	Balancing	L1	0% - Decreases the closing duration	Allows for increasing or decreasing the duration of the closing manoeuvre. This is useful when the motor moves in the two directions at different speeds (for example, hydraulic motors) or when the leaves are unbalanced and require different force levels during the opening and closing manoeuvres, covering the same distance with different times. If the closing manoeuvre must be increased, shift the setting towards L8; if the closing manoeuvre must be decreased, shift the setting towards L1.
		L2	20 %	
		L3	30 %	
		L4	40 %	
		L5	60 %	
		L6	70 %	
		L7	80 %	
		L8	100% - Increases the closing duration	
L6	Motor force	L1	25% - Minimum force	Adjusts the force of both motors through the phase partialisation expressed in percentage.
		L2	35 %	
		L3	45 %	
		L4	55 %	
		L5	65 %	
		L6	75 %	
		L7	85 %	
		L8	100% - Maximum force	
L7	Start-up time	L1	0 s	Allows for programming the start-up duration at the start of a manoeuvre.
		L2	0.5 s	
		L3	1 s	
		L4	1.5 s	
		L5	1.8 s	
		L6	2 s	
		L7	2.5 s	
		L8	3 s	
L8	Pedestrian or partial opening	L1	Pedestrian 1 (the M2 gate leaf opens to 1/4 of the full length)	Adjusts the type of opening associated with the "partial opening 1" command. In levels L5, L6, L7 and L8, "minimum" opening refers to the smallest opening between M1 and M2; for example, if M1 opens to 90° and M2 opens to 110°, the minimum opening is 90°.
		L2	Pedestrian 2 (the M2 gate leaf opens to 1/2 of the full length)	
		L3	Pedestrian 3 (the M2 gate leaf opens to 3/4 of the full length)	
		L4	Pedestrian 4 (full opening of gate leaf 2)	
		L5	Partial 1 (the two gate leaves open to 1/4 of the "minimum" opening level)	
		L6	Partial 2 (the two gate leaves open to 1/2 of the "minimum" opening level)	
		L7	Partial 3 (the two gate leaves open to 3/4 of the "minimum" opening level)	
		L8	Partial 4 (the two gate leaves open to the "minimum" opening level)	

6.4 SPECIAL FUNCTIONS

6.4.1 "MOVE ANYWAY" FUNCTION

This function can be used to operate the automation even one or more safety devices fail to work properly or are out of order. The automation can be controlled in "hold-to-run" mode by proceeding as follows:

1. send a command to operate the gate, using a transmitter or key selector, etc. If everything functions properly, the gate will move normally, otherwise proceed with point 2
2. within 3 seconds, press the control again and hold it down
3. after roughly 2 seconds, the gate will complete the requested manoeuvre in "hold-to-run" mode, in other words, it will continue to move so long as the control is held down.

6.4.2 "MAINTENANCE NOTICE" FUNCTION (CONFIGURABLE WITH AN EXTERNAL PROGRAMMER)

This function allows for signalling to the user when the automation needs maintenance. The maintenance signal is given through a lamp connected to the "OGI" output, if this output is configured as a "Maintenance indicator".

The configuration is only possible through the "Oview" programmer (refer to the "Connecting the IBT4N interface" paragraph).



The various indicator lamp signals are shown in "Table 7".

Table 7

"MAINTENANCE INDICATOR" SIGNAL	
Number of manoeuvres	Signal
Below 80% of the limit	Lamp stays lit for 2 seconds at the start of the opening manoeuvre.
Between 81% and 100% of the limit	Lamp flashes for the entire duration of the manoeuvre.
Over 100% of the limit	Lamp flashes continuously.

6.5 MEMORY DELETION



The procedure described below restores the control unit's default settings. All the custom settings will be lost.

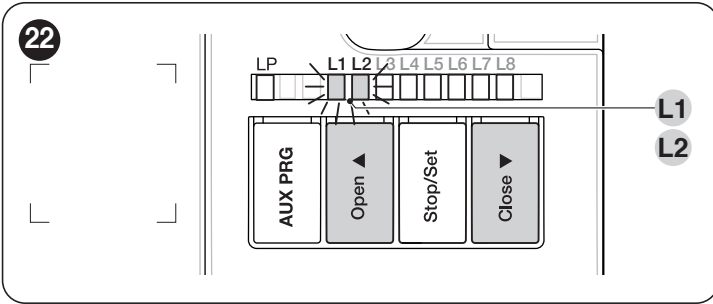

To delete the control unit's memory and restore all the default settings, proceed as described below:

1. press and hold the [Open ▲] and [Close ▼] buttons until LEDs "L1" and "L2" start flashing
2. release the buttons.

7

TROUBLESHOOTING GUIDE

Some devices are configured for signalling the operating status or the presence of any anomalies.

If any anomalies occur, the "BlueBus" (A) LED ("Figure 23") will emit some flashes. "Table 8" describes the cause and possible solution for each type of signal.

LEDs (B) and (L1..L4) ("Figure 23"), located on the control unit, will also emit signals. "Table 9 and Table 10" describe the cause and possible solution for each type of signal.

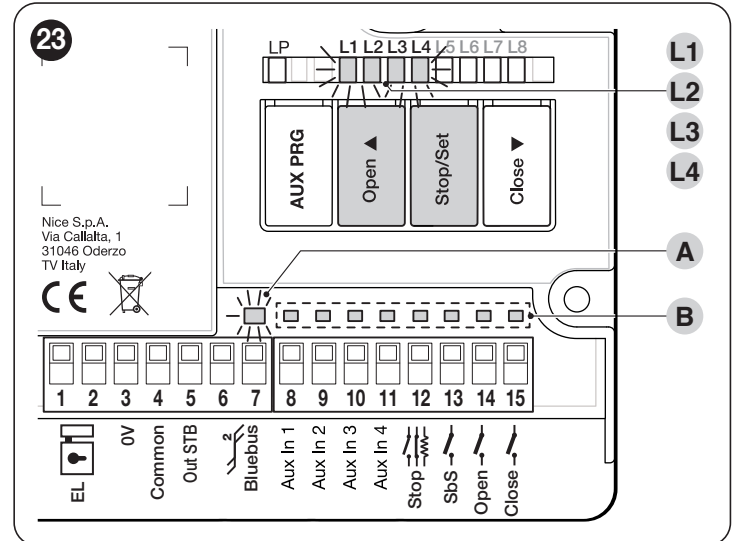

Table 8

SIGNALS OF THE BLUEBUS (A) LED ("FIGURE 23")		
Flashes	Anomaly	Possible solution
1 short red flash 1-second pause 1 short red flash	BlueBus system error	The check to verify the devices connected to the BlueBus system, run at the start of the manoeuvre, does not reveal the same devices memorised during learning phase. There may be some disconnected or faulty devices: check these and replace them if necessary. Some changes were made: the device learning procedure must be rerun.
2 short red flashes 1-second pause 2 short red flashes	Intervention of a photocell	One or more photocells do not consent to the movement or have caused the latter to reverse; check for any obstacles.
4 short red flashes 1-second pause 4 short red flashes	Intervention of the "Stop" input	At the start of the manoeuvre or during the movement itself, one of the devices connected to the Stop input intervened: identify the cause.
5 short red flashes 1-second pause 5 short red flashes	Error in the internal parameters of the control unit	Wait at least 30 seconds then try giving a command again and disconnect the power supply, if necessary. If the condition persists, there may be a serious fault requiring the electronic board to be replaced.
7 short red flashes 1-second pause 7 short red flashes	Electric circuit anomaly	Wait at least 30 seconds then try giving a command again and disconnect the power supply, if necessary. If the condition persists, carry out the following check to verify which other LED remains lit so, in order to assign one of the following explanations: L1 flashing: intervention of the motor protection devices, or motors disconnected; L2 flashing: limit switch anomaly (limit switches learned but with anomaly status); L3 flashing: limit switch anomaly (limit switches not learned but present); L4 flashing: generic anomaly. if, after identifying and resolving the anomaly, the condition persists, there may be a serious fault requiring the electronic board to be replaced.
8 short red flashes 1-second pause 8 short red flashes	A command that prevents other commands from being executed is already present	Check the type of command that is always present; for example, it could be a command from a timer on the "open" input.
9 short red flashes 1-second pause 9 short red flashes	The automation was stopped by a "Stop automation" command	Unlock the automation mechanism by giving the "Unlock automation" command.

SIGNALS OF LED (B) ("FIGURE 23")		
Status	Meaning	Possible solution
All LEDs		
No LED is lit	No power to the control unit	Check whether the control unit is powered. Check that the fuse (A - "Figure 1") has not blown. If the fuse has blown, verify the cause and replace it with one having the same characteristics. If also the "BlueBus" LED is not lit or flashing, there probably is a serious fault that requires the control unit to be replaced.
BLUEBUS LED		
Green LED always off	Anomaly	Check whether the control unit is powered. Check that the fuse (A - "Figure 1") has not blown. If the fuse has blown, verify the cause and replace it with one having the same characteristics.
Green LED always on	Serious anomaly	There is a serious problem: try disconnecting the power supply to the control unit and if the condition persists, replace the electronic board.
1 flash per second of the green LED	Everything normal	Normal control unit operation.
2 fast flashes of the green LED	Variation of the status of the inputs	This is normal if there is a change in one of the "SbS", "Stop", "Open" or "Close" inputs, the control photocells intervene or a command is transmitted with a transmitter.
Series of flashes of the red LED divided by a 1-second pause	Various	Refer to that shown in "Table 8".
STOP LED		
OFF	Intervention of the "Stop" input	Check the devices connected to the "Stop" input.
On	All OK	"Stop" input active.
SbS LED		
OFF	All OK	"SbS" input not active.
On	Intervention of the "SbS" input	Normal if the device connected to the "SbS" input is active.
OPEN LED		
OFF	Everything normal	"Open" input not active.
On	Intervention of the "Open" input	This is normal if the device connected to the "Open" input is active.
CLOSE LED		
OFF	Everything normal	"Close" input not active.
On	Intervention of the "Close" input	This is normal if the device connected to the "Close" input is active.
LS1 OPEN LED		
OFF	Intervention of the "LS1 Open" input	This is normal if the device connected to the "LS1 Open" input is active.
On	Everything normal	"LS1 Open" input active.
LS1 CLOSE LED		
OFF	Intervention of the "LS1 Close" input	This is normal if the device connected to the "LS1 Close" input is active.
On	Everything normal	"LS1 Close" input active.
LS2 OPEN LED		
OFF	Intervention of the "LS2 Open" input	This is normal if the device connected to the "LS2 Open" input is active.
On	Everything normal	"LS2 Open" input active.
LS2 CLOSE LED		
OFF	Intervention of the "LS2 Close" input	This is normal if the device connected to the "LS2 Close" input is active.
On	Everything normal	"LS2 Close" input active.

SIGNALS OF LED (L1..L4) ("FIGURE 23")		
Status	Meaning	Possible solution
LEDs L1 - L2		
Slow flashing	Change in the number of devices connected to the "BlueBus" or learning of the device not executed.	It is necessary to run the device learning procedure (refer to the "Learning of connected devices" paragraph)
LEDs L3 - L4		
Slow flashing	The positions of the mechanical stops were never learned or after the mechanical stop learning procedure, the dip-switch configuration changed.	It is necessary to run the device learning procedure (refer to the "Learning of connected devices" paragraph)

8 FURTHER DETAILS (Accessories)

8.1 CONNECTING AN SM-TYPE RADIO RECEIVER

The control unit has a slot for mounting radio receivers with SM connector (optional accessories), which can be used to remotely control the control unit through transmitters that intervene on the unit's inputs.

 **Before installing a receiver, disconnect the power supply to the control unit.**

To install a receiver ("Figure 24"):

1. remove the cover of the control unit's containment box
 2. insert the receiver (A) in the appropriate slot (B) on the control unit's electronic board
 3. put the cover of the control unit's containment box back on.
- At this stage, the control unit can be powered again.

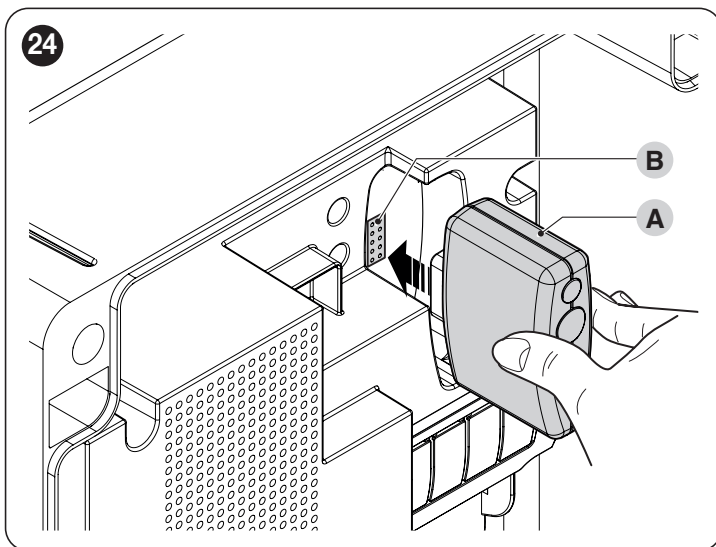

"Table 11" and "Table 12" show the "Receiver outputs" and the "Control unit inputs" associated with each.

Table 11

SMXI / SMXIS OR OXI / OXIFM / OXIT / OXITFM IN MODE 1 OR MODE 2	
Receiver output	Control unit input
Output No. 1	"SbS" (Step-by-Step) command
Output No. 2	"Partial opening 1" command
Output No. 3	"Open" command
Output No. 4	"Close" command

Table 12

OXI / OXIFM / OXIT / OXITFM IN MODE 2 EXTENDED		
No.	Command	Description
1	Step-by-Step	"SbS" (Step-by-Step) command
2	Partial opening 1	"Partial opening 1" command
3	Open	"Open" command
4	Close	"Close" command
5	Stop	Stops the manoeuvre
6	Condominium Step-by-Step	Command in condominium mode
7	High priority Step-by-Step	Commands also with the automation locked or the commands enabled
8	Partial open 2	Partial opening (the M2 gate leaf opens to 1/2 the full length)
9	Partial open 3	Partial open (the two gate leaves open to 1/2 the full length)
10	Opens and locks the automation	Triggers an opening manoeuvre and, once this terminates, locks the automation; the control unit will not accept any command other than "High priority Step-by-Step" and automation "Unlock", or (only from Oview) the following commands: "Unlock and close" and "Unlock and open"
11	Closes and locks the automation	Triggers a closing manoeuvre and, once this terminates, locks the automation; the control unit will not accept any command other than "High priority Step-by-Step" and automation "Unlock", or (only from Oview) the following commands: "Unlock and close" and "Unlock and open"
12	Lock automation	Triggers the stoppage of the manoeuvre and locks the automation; the control unit will not accept any command other than "High priority Step-by-Step" and automation "Unlock", or (only from Oview) the following commands: "Unlock and close" and "Unlock and open"
13	Release automation	Triggers unlocking of the automation and restores normal operation
14	On Timer Courtesy light	The courtesy light output switches on with timer-based switching off
15	On-Off Courtesy light	The courtesy light output switches on and off in Step-by-step mode



For further information, consult the specific manual of the receiver.

8.2 CONNECTING THE IBT4N INTERFACE

The control unit is equipped with a "IBT4N"-type connector for the IBT4N interface, which allows for connecting all devices equipped with BusT4 interface, such as, for example, Oview programmers and the IT4WIFI Wi-Fi interface.

The Oview programmer allows for comprehensively and rapidly managing the installation, maintenance and diagnosis of the entire automated system.



Before connecting the interface, disconnect the power supply to the control unit.

To install the interface ("Figure 25"):

1. remove the cover of the control unit's containment box
2. place the interface (A) in the appropriate slot (B) on the control unit's electronic board
3. insert the cable (C) in the appropriate slot (D) on the interface
4. put the cover of the control unit's containment box back on.

At this stage, the control unit can be powered again.

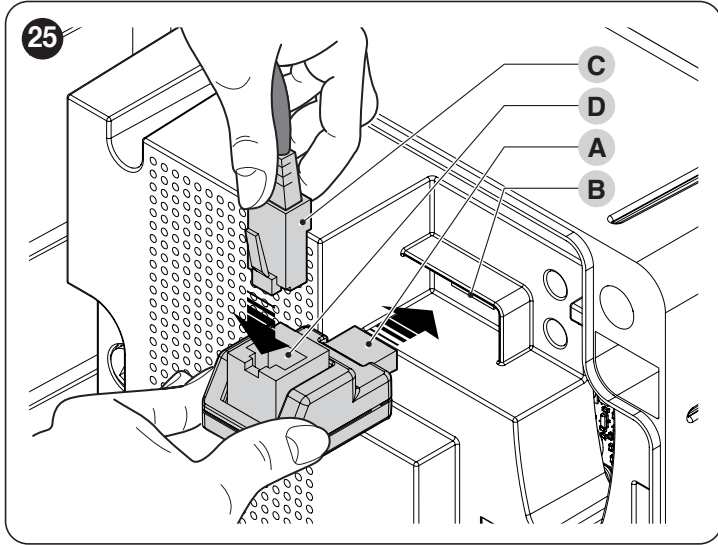

For further information, consult the specific manuals of the connected devices.

10 PRODUCT DISPOSAL



This product is an integral part of the operator and must therefore be disposed of with it.

As with the installation, only qualified personnel must dismantle the product at the end of its life.

This product is composed of different types of materials. Some of these materials can be recycled; others must be disposed of. Please enquire about the recycling or disposal systems in place in your local area for this type of product.



WARNING

Some parts of the product may contain polluting or dangerous substances. If not disposed of correctly, these substances may have a damaging effect on the environment and human health.



As indicated by the symbol shown here, this product must not be disposed of with household waste. Separate the waste for disposal and recycling, following the methods stipulated by local regulations, or return the product to the seller when purchasing a new product.



WARNING

Local regulations may impose heavy penalties if this product is not disposed of in compliance with the law.

9

PRODUCT MAINTENANCE

Being an electronic part, the control unit does not require any special maintenance. Nonetheless, the system should be regularly checked to ensure that it works efficiently at least every 6 months according to the instructions in the "**TESTING AND COMMISSIONING**" chapter.

11 TECHNICAL SPECIFICATIONS



All technical specifications stated in this section refer to an ambient temperature of 20°C (± 5°C). Nice S.p.A. reserves the right to apply modifications to the product at any time when deemed necessary, without altering its functions and intended use.

Table 13

TECHNICAL SPECIFICATIONS	
Description	Technical specification
MC800 power supply	120/250V~50/60Hz
Nominal power absorbed by the mains grid	900 W
Consumption in Stanby mode	< 0,5 W (without accessories and with any photocells connected as in ("Figure 7"))
Warning light output	1 beacon (lamp 120/250V, 21 W)
Electric lock output	1 x 12 V~ max 15 VA electric lock
STB Output Out	24 V output for relay photocell power supply, see ("Figure 7"). Maximum power consumption: 4W. The output turns off in standby.
BLUEBUS output	1 output with maximum load of 15 Bluebus units (maximum 6 pairs of MOFB or MOFOB photocells + 2 pairs of MOFB or MOFOB photocells addressed as opening devices + maximum 4 MOMB or MOTB control devices)
STOP input	for normally closed or normally open contacts or for 8.2 kΩ fixed resistor contacts with self-learning (any variation from the memorised status triggers the "STOP" command)
SbS input	for normally open contacts (closing of the contact triggers the Step-by-Step command)
OPEN input	for normally open contacts (the closing of the contact causes the OPEN command)
CLOSE input	for normally open contacts (the closing of the contact causes the CLOSE command)
Radio connector	SM connector for receivers
Radio ANTENNA input	50 Ω for RG58-type cable or similar
Programmable functions	8 ON-OFF and 8 adjustable functions
Self-learning functions	Self-learning of the devices connected to the BlueBus output; self-learning of the type of device connected to the "STOP" terminal (NO, NC contact, 8.2 kΩ fixed resistor, or 4K1 double edge); self-learning of the gate path and automatic calculation of the slowdown and partial opening points
Operating temperature	-20°C to +55°C
Use in highly acid, saline or potentially explosive atmosphere	NO
Protection rating	IP 54 with container intact
Dimensions (mm)	310 x 232 x H 122
Weight (kg)	4,1

12 CONFORMITY

Nice S.p.A. manufacturer of this equipment declares that it conforms to Directive 2014/30/EU (EMC) and Directive 2006/42/EC of the European Parliament and of the Council of 17 May 2006 on machinery, and amending Directive 95/16/EC (recast). The instruction manual and the full text of the EU Declaration of Conformity can be found at the following Internet address: www.niceforyou.com; under 'support' and 'download'.

NOTES

A series of horizontal dashed lines for writing notes.

INSTRUCTIONS AND WARNINGS FOR USE

Before using the automation system for the first time, ask the installer to explain the origin of residual risks and take a few minutes and read this instructions manual and related warnings handed to you by the installer. Keep the manual for consultation when in doubt and ensure supply to new owners of the automation.



WARNING!

Your automation is a machine that faithfully executes commands imparted by the user. Negligence and improper use may lead to dangerous situations:

- do not manoeuvre the gate if there are people, animals or objects within its range of operation
- it is strictly forbidden to touch parts of the automation while it is moving
- the photocells should not be regarded as actual safety devices but only as auxiliary safety devices. They are designed using highly reliable technology, but in extreme conditions may be subject to malfunctions or potential faults, and in certain cases these faults might not be immediately evident
- periodically check that the photocells work properly.



IT IS STRICTLY FORBIDDEN to transit while the automation is closing! Transit is allowed only if the automation is fully open and stationary.



CHILDREN

An automation system guarantees a high degree of safety. With its detection systems, it can control and guarantee the gate's movement in the presence of people or objects. It is nonetheless advisable to forbid children from playing near the automation and not to leave remote controls near them to prevent any unwanted activation of the system. The automation is not a toy!

The product is not intended for use by persons, including children, with limited physical, sensory or mental capacities, or who lack experience or knowledge, unless supervised or trained in the use of the product by a person responsible for their safety.

Anomalies: if the automation appears to behave strangely, disconnect the power supply to the automation and manually unlock the motor (consult the respective instruction manual) to manoeuvre the gate manually. Do not perform any repairs personally, but contact your trusted installer.



Do not modify the system or the programming and adjustment parameters of the control unit: your installer is exclusively responsible for these operations.

Failure or power outage: while waiting for your installer to intervene or the power supply to be restored, if the system is not equipped with back-up batteries, the automation can be used by manually unlocking the motor (consult the relative instruction manual) and manually moving the gate leaf.

Safety devices out of order: the automation can also be used when one or more safety devices are defective or out of order. The automation can be controlled in "Hold-to-run" mode in the following way:

1. send a command to operate the gate, with a transmitter or key selector, etc. If everything works properly, the gate will move normally, otherwise proceed as described below
2. within 3 seconds, press the control again and hold it down
3. after roughly 2 seconds, the gate will move in the "hold-to-run" mode, in other words, it will continue moving so long as the control is held down.



If the safety devices are out of order, have the system repaired as soon as possible by a qualified technician.

The test, periodic maintenance and any repairs must be documented by the person carrying out the work and the documents must be stored by the owner of the automation. The only interventions the user may carry out periodically include cleaning of the photocell glass components (use a soft and slightly damp cloth) and removing any leaves or stones that may obstruct the automation.



The user of the automation must manually unlock the motor before starting any maintenance operation, to prevent other people from accidentally manoeuvring the gate (consult the respective instruction manual).

Maintenance: in order to ensure constant levels of safety and the longest useful life for the automation, routine maintenance must be carried out (at least every 6 months).



Only qualified personnel is authorised to carry out checks, maintenance operations and repairs.

Disposal: at the end of its useful life, the automation must be dismantled by qualified personnel and the materials must be recycled or disposed of in compliance with the local regulations in force.



If the automation was locked using the "Lock automation" command, the gate will not move when a command is sent and the warning light will emit 9 short flashes.

NOTES



A series of horizontal dashed lines for writing notes, spanning the width of the page.



NOTES

A series of horizontal dashed lines for writing notes.



Nice SpA
Via Callalta, 1
31046 Oderzo (TV)
Italia

www.niceforyou.com

IS054C00EN_17-09-2025