

Hopp

HO7124

HO7224

CE
EAC



Swing gate opener

EN - Instructions and warnings for installation and use

Nice

CONTENTS

1	GENERAL SAFETY WARNINGS AND PRECAUTIONS	3
1.1	General warnings	3
1.2	Installation warnings	3
2	PRODUCT DESCRIPTION AND INTENDED USE	4
2.1	List of constituent parts	4
3	INSTALLATION	5
3.1	Pre-installation checks	5
3.2	Product usage limits	5
3.2.1	Product durability	6
3.3	Product identification and overall dimensions	6
3.4	Pre-installation works	7
3.5	Installing the gearmotor	8
3.6	Adjusting the mechanical limit switches	10
3.7	Manually unlocking and locking the gearmotor	11
4	ELECTRICAL CONNECTIONS	11
4.1	Preliminary checks	11
4.2	Wiring diagram and description of connections	13
4.2.1	Wiring diagram	13
4.2.2	Description of connections	13
5	FINAL CHECKS AND START-UP	14
5.1	Power supply connection	14
5.2	Device learning	14
5.3	Learning of the mechanical stop positions	14
5.3.1	Learning in automatic mode	15
5.3.2	Learning in manual mode	15
5.3.3	Learning in mixed mode	16
5.4	Checking the gate movement	16
5.5	Connecting other devices	16
6	TESTING AND COMMISSIONING	17
6.1	Testing	17
6.2	Commissioning	17
7	PROGRAMMING	17
7.1	Using the programming buttons	17
7.2	Level 1 programming (ON-OFF)	18
7.2.1	Level 1 programming procedure	18
7.3	Level 2 programming (adjustable parameters)	19
7.3.1	Level 2 programming procedure	19
7.4	Special functions	21
7.4.1	"Move anyway" function	21
7.4.2	"Maintenance notice" function	21
7.4.3	Verifying the number of manoeuvres completed	21
7.5	Memory deletion	21
8	TROUBLESHOOTING GUIDE	22
8.1	Anomaly log	22
8.2	Signalling through warning light	22
8.3	Signals on the control unit	23
9	FURTHER DETAILS (Accessories)	24
9.1	Adding or removing devices	24
9.1.1	BlueBUS	24
9.1.2	STOP input	24
9.1.3	Photocells	24
9.1.4	Learning of other devices	25
9.2	Connecting an OXl radio receiver	25
9.3	Connecting and installing the emergency power supply	26
9.4	Connecting the external unlocking system Kio	26
9.5	Connecting the Oview programmer	27
9.6	Connecting the Solemyo solar energy system	28
10	PRODUCT MAINTENANCE	29
11	PRODUCT DISPOSAL	29
12	TECHNICAL SPECIFICATIONS	30
13	CONFORMITY	32
	INSTRUCTIONS AND WARNINGS FOR USE	34

1.1 GENERAL WARNINGS



WARNING! Important safety instructions. Observe all the instructions as improper installation may cause serious damages.



WARNING! Important safety instructions. It is important to comply with these instructions to ensure personal safety. Store these instructions carefully.

WARNING! Please abide by the following warnings:

- Before commencing the installation, check the "Product technical specifications", in particular whether this product is suitable for automating your guided part. Should it not be suitable, do NOT proceed with the installation.
- The product cannot be used before it has been commissioned as specified in the "Testing and commissioning" chapter.



According to the latest European legislation, an automated device must be constructed in conformity to the harmonised rules specified in the current Machinery Directive, which allow for declaring the presumed conformity of the automation. Consequently, all the operations for connecting the product to the mains electricity, its commissioning and maintenance must be carried out exclusively by a qualified and expert technician.

- Before proceeding with the product's installation, check that all the materials are in good working order and suited to the intended applications.
- The product is not intended for use by persons (including children) with reduced physical, sensory or mental capacities, nor by anyone lacking sufficient experience or familiarity with the product.
- Children must not play with the appliance.
- Do not allow children to play with the product's control devices. Keep the remote controls out of reach of children.



In order to avoid any danger from inadvertent resetting of the thermal cut-off device, this appliance must not be powered through an external switching device, such as a timer, or connected to a supply that is regularly powered or switched off by the circuit.

- The system's power supply network must include a disconnection device (not supplied) with a contact opening gap permitting complete disconnection under the conditions envisaged by Overvoltage Category III.
- Handle the product with care during installation, taking care to avoid crushing, denting or dropping it, or allowing contact with liquids of any kind. Keep the product away from sources of heat and naked flames. Failure to observe the above can damage the product, and increase the risk of danger or malfunction. Should this happen, stop installation immediately and contact Customer Service.

- The manufacturer declines all liability for damages to property, objects or people resulting from failure to observe the assembly instructions. In such cases, the warranty for material defects shall not apply.
- The weighted sound pressure level of the emission A is lower than 70 dB(A).
- Cleaning and maintenance reserved for the user must not be carried out by unsupervised children.
- Before intervening on the system (maintenance, cleaning), always disconnect the product from the mains power supply and from any batteries.
- Inspect the system frequently, in particular the cables, springs and supports to detect any imbalances and signs of wear or damage. Do not use the product if it needs to be repaired or adjusted, because defective installation or incorrect balancing of the automation can lead to injuries.
- The packing materials of the product must be disposed of in compliance with local regulations.
- Keep persons away from the gate when it is manoeuvred using the control elements.
- When operating the gate, keep an eye on the automated mechanism and keep all bystanders at a safe distance until the movement has been completed.
- Do not operate the product if anyone is working nearby; disconnect its power supply before permitting such work to be done.
- If the power cable is damaged, it must be replaced by the manufacturer or by an appointed servicing company or similarly qualified person in order to prevent any form of risk.
- Warning! Transport the product using the relevant hand trolley and the handles on the package to ensure that the operations are conducted safely.

1.2 INSTALLATION WARNINGS

- Prior to installing the drive motor, check that the door is in good working order, correctly balanced and that it opens and closes properly.
- Before installing the drive motor, remove all unnecessary ropes or chains and deactivate any equipment not required for motorised operation, such as locking devices.
- If the gate to be automated is fitted with a pedestrian door, the system must be equipped with a control system that inhibits motor operation when the pedestrian door is open
- Install the manoeuvre device for manual unlocking at less than 1.8 m above the ground. NOTE - If removable, the manoeuvre device must be kept next to the door when removed.
- Make sure that the control elements are kept far from moving parts but nonetheless directly within sight. Unless a selector is used, the control elements must be installed at least 1.5 m above the ground and must not be accessible.

- If the opening movement is controlled by a fire-sensing system, make sure that any windows larger than 200 mm are closed using the control elements.
- Prevent and avoid any form of entrapment between the moving and fixed parts during the manoeuvres.
- Permanently affix the label concerning the manual manoeuvre near its actuating element.
- After installing the drive motor, make sure that the mechanism, protective system and all manual manoeuvres function properly.
- Doors and vertical gates require an anti-fall function or device
- For drive motors that allow for accessing unprotected moving parts once they have been installed, such parts must be installed at least 2.5 m above the floor or other surface from which they can be accessed.
- Make sure to avoid any entanglements due to the opening movement of the driven part.
- After the installation, make sure that the mechanism is correctly adjusted and that the protection system and the manual release device (if present) work properly.

Battery-operated appliances

- The appliance must be disconnected from the power supply when removing the batteries.
- The batteries must be removed from the appliance prior to its disposal.
- The batteries must be safely disposed of.
- If the batteries are not rechargeable, do not replace them with rechargeable batteries.

Appliances with LED light

- Looking at LED lights from close up and for prolonged periods can cause dazzling. It may temporarily reduce eyesight and cause accidents.
- Avoid looking at LEDs directly.

Appliances with radio device

- For transmitters: 433 MHz: ERP < 10 dBm - 868 MHz: ERP < 14 dBm; for receivers: 433 MHz, 868 MHz.

2 PRODUCT DESCRIPTION AND INTENDED USE

HOPP is a series of gearmotors with articulated arm and external assembly, which can be used to automate residential or industrial swing gates or doors. They are equipped with a sturdy anti-shear aluminium arm and are ideal for intensive use.

The main part of the automation consists of one or more electromechanical gearmotors (depending on the number of leaves to be automated), each equipped with a direct-current motor and a gear reducer with spur gears.

The **HO7124** gearmotor is equipped with a control unit that manages its operation.

The control unit is configured for being connected to the various devices belonging to the Opera System, Bluebus system and the Solemyo solar power system.

Hopp operates using electrical power. In the event of a power outage from the electrical grid, it is possible to unlock the system using a special key and manually move the automation, or alternatively, use the optional back-up battery accessory PSS124, which allows for some maneuvers even in the absence of grid power.

The automation allows for installing various accessories to increase its functions and improve safety.

This product complies with the criteria set forth in the "Standby" regulation. The product enters Standby Mode 5 minutes (configurable) after the completion of a successfully executed operation.



CAUTION! – Any use other than that specified herein or in environmental conditions other than those stated in this manual is to be considered improper and is strictly forbidden!

2.1 LIST OF CONSTITUENT PARTS

"Figure 1" shows the main parts making up the **HO7124** gearmotor.

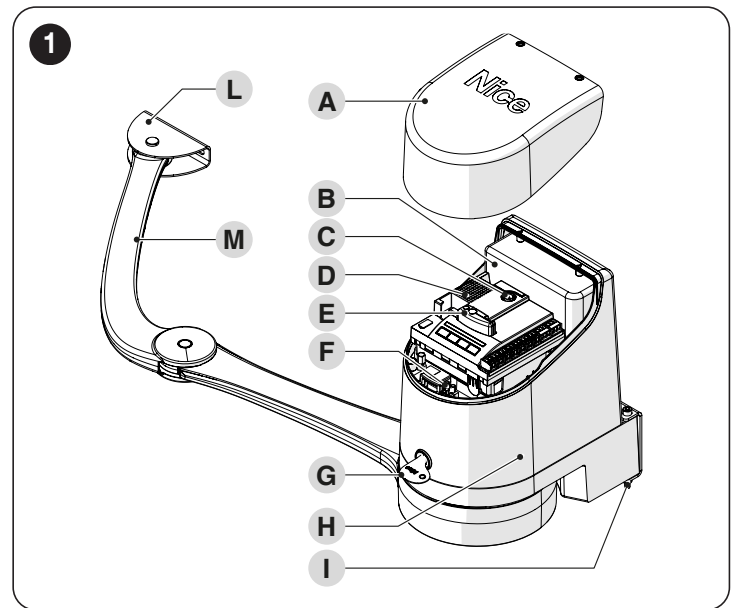

- A** Cover
- B** Back-up battery (accessory)
- C** Fuse
- D** Electronic control and command unit (only present on **HO7124**)
- E** OXI receiver
- F** Power supply connector
- G** Locking/unlocking key
- H** Gearmotor
- I** Gearmotor fixing bracket
- L** Arm fixing bracket
- M** Arm

3 INSTALLATION

3.1 PRE-INSTALLATION CHECKS

⚠ The installation must be carried out by qualified personnel in compliance with the current legislation, standards and regulations, and with the instructions provided in this manual.

Before proceeding with the product's installation, it is necessary to:

- check the integrity of the supply
- check that all the materials are in good working order and suited to the intended use
- make sure that the structure of the gate is suitable for being automated
- make sure that the weight and dimensions of the gate leaf fall within the operating limits specified in the "**Product usage limits**" paragraph
- check that the installation location is compatible with the overall clearance of the product (see "**Figure 5**")
- make sure that there is enough space in the installation location for the gearmotor's arm to rotate fully (see "**Figure 2**")

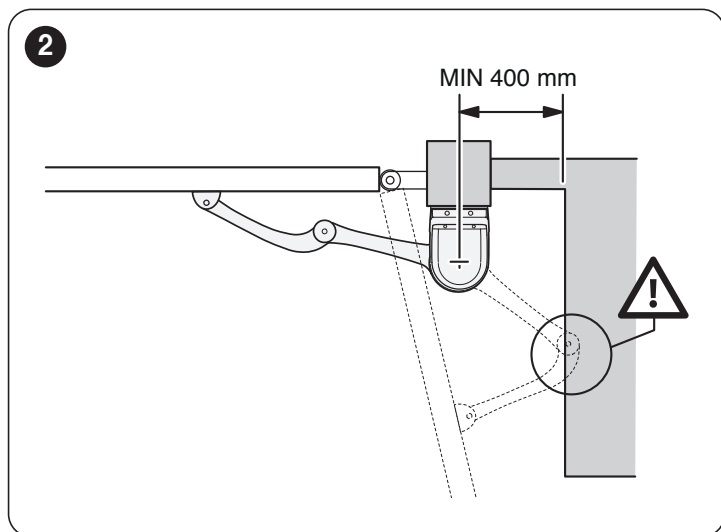

- verify that there are no points of greater friction during the opening and closing movements along the entire gate path
- verify that the overrun mechanical stops are sturdy enough and that they do not deform even if the leaf should strike them forcefully
- verify that the gate leaf is well balanced: it must not move by itself when left in any position
- make sure that the installation area is not subject to flooding; if necessary, the product must be installed appropriately raised above ground level
- verify that the area where the gearmotor is installed allows for unlocking the latter and manoeuvring easily and safely

- verify that the mounting positions of the various devices are protected against impacts and that the mounting surfaces are sufficiently sturdy
- prevent any parts of the automation from being immersed in water or other liquids
- keep the product away from heat sources and open flames and acid, saline or potentially explosive atmospheres; these may damage the product and cause malfunctions or dangerous situations
- if there is an access door in the gate, or within its range of movement, make sure that it does not obstruct the gate's normal path; install an appropriate interlock system if necessary
- connect the control unit to an electricity supply line equipped with a safety earthing system
- connect the gate to the earthing device in accordance with the current legislation
- Mount a device on the electric power line that completely disconnects the automation from the grid. The disconnection device must have contacts with a sufficient gap to ensure complete disconnection, under the Category III overvoltage conditions, in accordance with the installation instructions. Should it be necessary, this device guarantees fast and safe disconnection from the power supply; it must therefore be positioned in view of the automation. If placed in a non-visible location, it must have a system that blocks any accidental or unauthorised reconnection of the power supply, in order to prevent dangerous situations. The disconnection device is not supplied with the product.

3.2 PRODUCT USAGE LIMITS

Carry out the following checks before installing the gearmotor:

- check that the leaf to be automated falls within the specified values (see "**Figure 3**")
- maximum width of the leaf: 2,4 m (with weight up to 160 kg)
- maximum weight of the leaf: 250 kg (with width up to 1,5 m)
- verify the limits for the values shown in the "**TECHNICAL SPECIFICATIONS**" chapter
- minimum width of the space reserved for the gearmotor's installation: 170 mm
- the arm's fixing bracket must be attached to a sturdy point of the leaf (for example, the frame), to guarantee solid and safe anchoring.

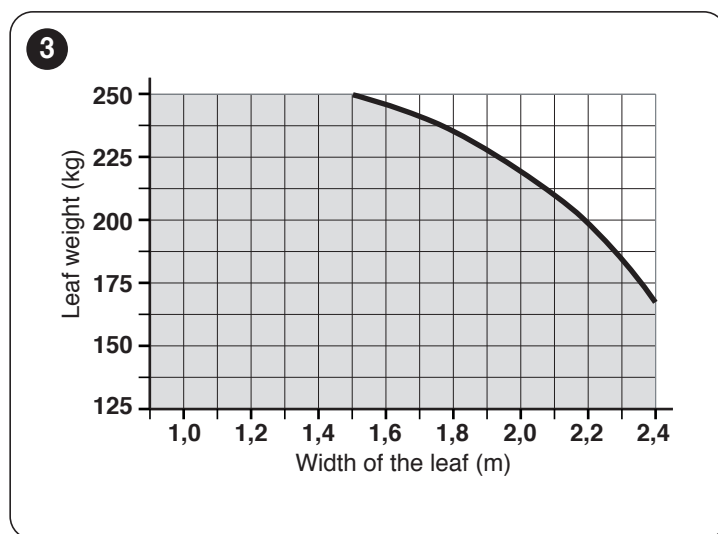

3.2.1 PRODUCT DURABILITY

The product's durability is its average economic life value and is strongly influenced by the degree of severity of the manoeuvres: in other words, the sum of all factors that contribute to product wear.

To estimate the durability of your automated device, proceed as follows:

1. add the values of the items in "Table 1" relative to the system's conditions
2. in the graph shown in "Figure 4", from the value obtained above, trace a vertical line until it intersects the curve; from this point trace a horizontal line until it intersects the line of the "manoeuvre cycles".

The value obtained is the estimated lifetime of your product.

The durability values shown in the graph can only be obtained if the maintenance schedule is strictly observed – see the "PRODUCT MAINTENANCE" chapter. The durability is estimated on the basis of the design calculations and the results of tests effected on prototypes. Being an estimate, therefore, it offers no explicit guarantee of the product's actual useful life.

Example of durability calculation: automation of a gate with a leaf length of 1.3 meters and a weight of 180 kg, for instance, with a solid leaf.

"Table 1" shows the "severity indices" for this type of installation: 15% ("Door length"), 30% ("Door weight") and 15% ("Solid leaf").

These indicators must be added together to obtain the overall severity index, which in this case is 60%. With the value identified (60%), look at the horizontal axis of the graph ("severity index") and identify the value corresponding to the number of "manoeuvre cycles" that the product can perform throughout its lifetime – roughly 100.000 cycles.

Table 1

PRODUCT DURABILITY		
		Severity index
Leaf length	< 1,0 m	0%
	1,0 - 1,5 m	15%
	1,5 - 2,4 m	20%
Leaf weight	< 100 kg	0%
	100 - 150 kg	20%
	150 - 250 kg	30%
Ambient temperature greater than 40°C or below 0°C, or humidity greater than 80%		20%
Solid leaf		15%
Installation in windy areas		15%

Note The data refers to a properly balanced sectional door in good working order.

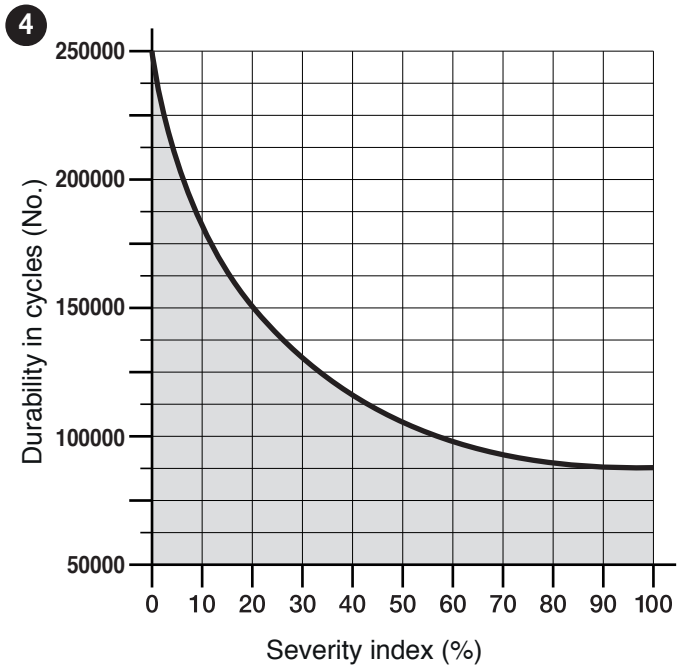

3.3 PRODUCT IDENTIFICATION AND OVERALL DIMENSIONS

The overall dimensions and the label (A), which allows for identifying the product, are shown in "Figure 5".

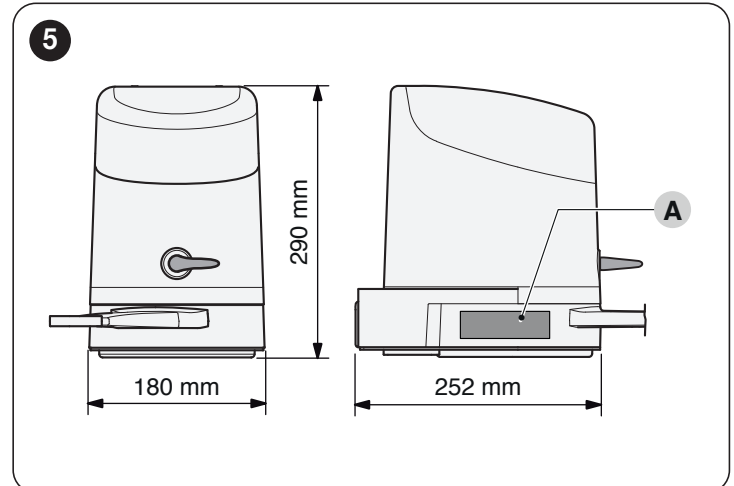

3.4 PRE-INSTALLATION WORKS

The figure shows an example of an automation system, constructed using **Nice** components.

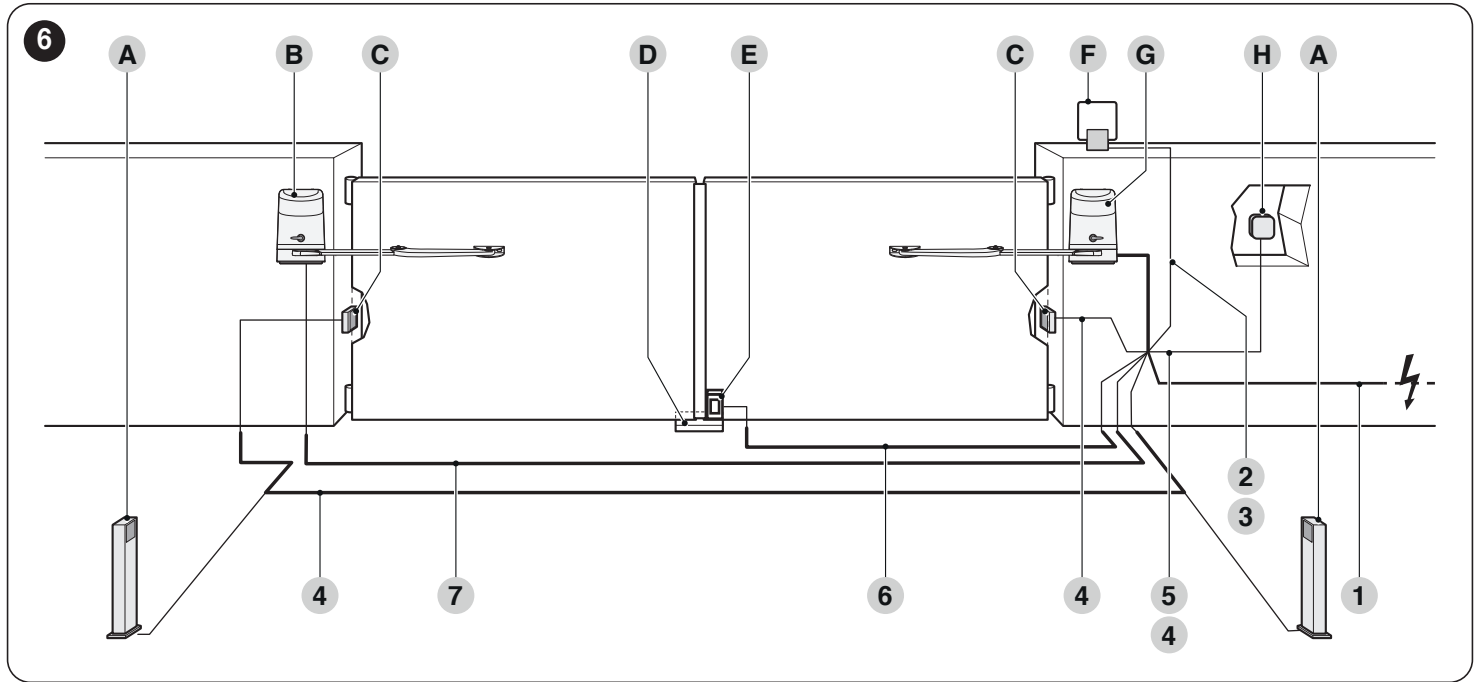

- A** Photocells on column
- B** Gearmotor without control unit (model **HO7224**)
- C** Photocells (model EPM)
- D** Mechanical stop at closed position
- E** Electric lock
- F** Warning light MLBT
- G** Gearmotor with control unit (model **HO7124**)
- H** Digital keypad (model EDSB) - Transponder reader (model ETPB) - Key selector EKSU)

These above-mentioned components are positioned according to a typical standard layout. Using the layout in **“Figure 6”** as a reference, define the approximate position in which each component of the system will be installed.

Table 2

TECHNICAL SPECIFICATIONS OF ELECTRICAL CABLES	
Identification no.	Cable characteristics
1	CONTROL UNIT POWER SUPPLY cable 1 cable 3 x 1.5 mm ² Maximum length 30 m [note 1]
2	WARNING LIGHT cable 1 cable 2 x 1 mm ² Maximum length 20 m
3	ANTENNA cable 1 x RG58-type shielded cable Maximum length 20 m; recommended < 5 m
4	BLUEBUS DEVICES cable 1 cable 2 x 0.5 mm ² Maximum length 20 m [note 2]
5	KEY SELECTOR cable 2 cables 2 x 0.5 mm ² [note 3] Maximum length 50 m
6	ELECTRIC LOCK cable 1 cable 2 x 1 mm ² Maximum length 6 m
7	GEARMOTOR POWER SUPPLY cable 1 cable 3 x 1.5 mm ² Maximum length 10 m

Note 1 If the power supply cable is longer than 30 m, a cable with larger cross-sectional area (3 x 2.5 mm²) must be used and a safety earthing system must be installed near the automation.

Note 2 If the BlueBus cable is longer than 20 m, up to maximum 40 m, it is necessary to use a cable with a greater cross-sectional area (2 x 1 mm²).

Note 3 These two cables can be replaced by a single 4 x 0.5 mm² cable.

⚠ Before proceeding with the installation, prepare the required electrical cables by referring to “Figure 6” and to that stated in the “TECHNICAL SPECIFICATIONS” chapter.

⚠ The cables used must be suited to the type of environment of the installation site.

⚠ When laying the pipes for routing the electrical cables, take into account that any water deposits in the junction boxes may cause the connection pipes to form condensate inside the control unit, thus damaging the electronic circuits.

3.5 INSTALLING THE GEARMOTOR

⚠ Incorrect installation may cause serious physical injury to the person working on the system or to its future users.

Before starting to assemble the automation, complete the preliminary checks described in the “Pre-installation checks” paragraph (page 5) and the “Product usage limits” paragraph (page 5).

To install **HOPP**:

1. measure the distance (A)

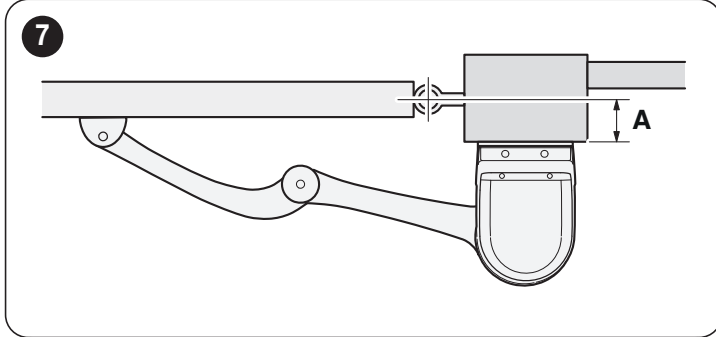

2. move the leaf to the desired maximum opening position and check the resulting opening angle
3. with the value of distance (A) and the opening angle found, using the graph to determine the distance (B). For example: if (A) is 100 mm and the desired angle is equal to 100°, distance (B) will measure roughly 180 mm

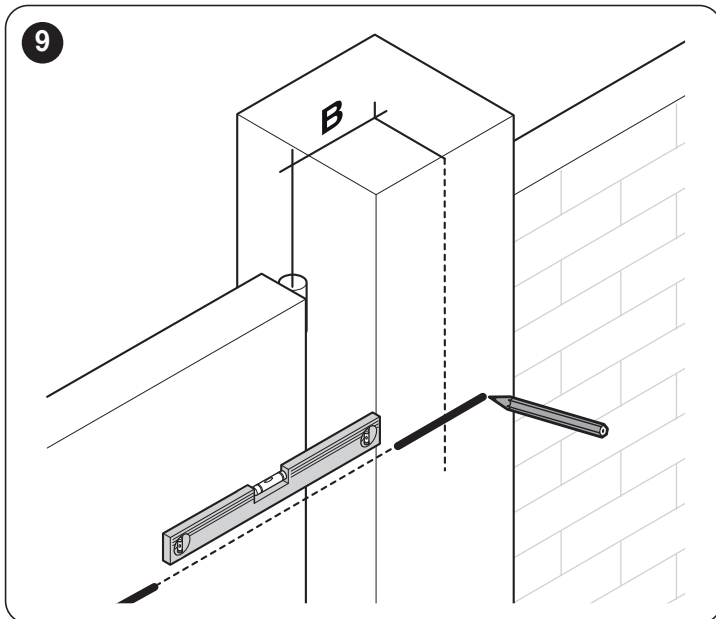
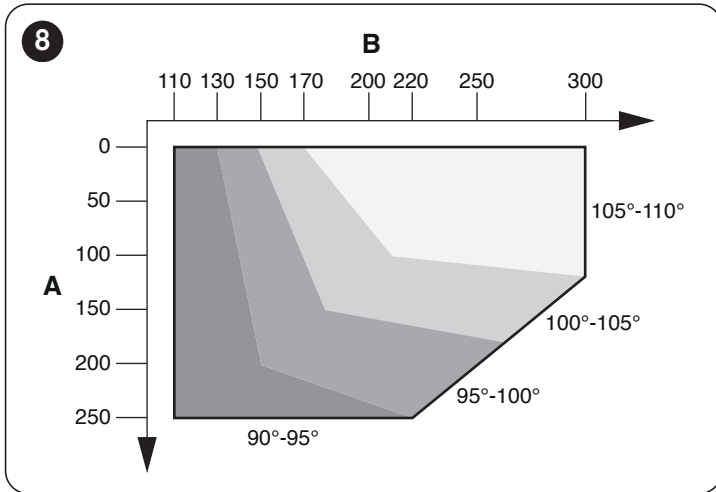

4. use the fixing bracket (C), in the horizontal position, as a template to determine the position of the four fixing holes

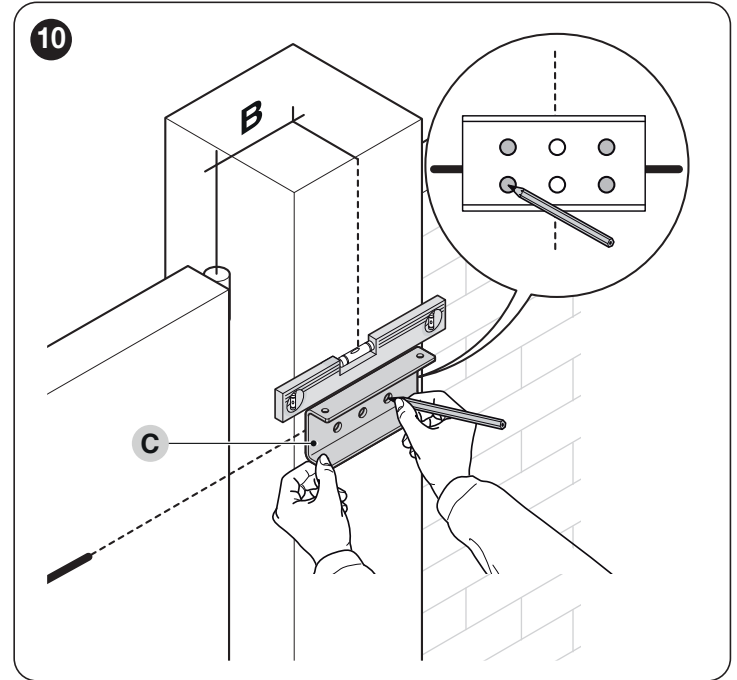

5. drill the bracket in the marked positions

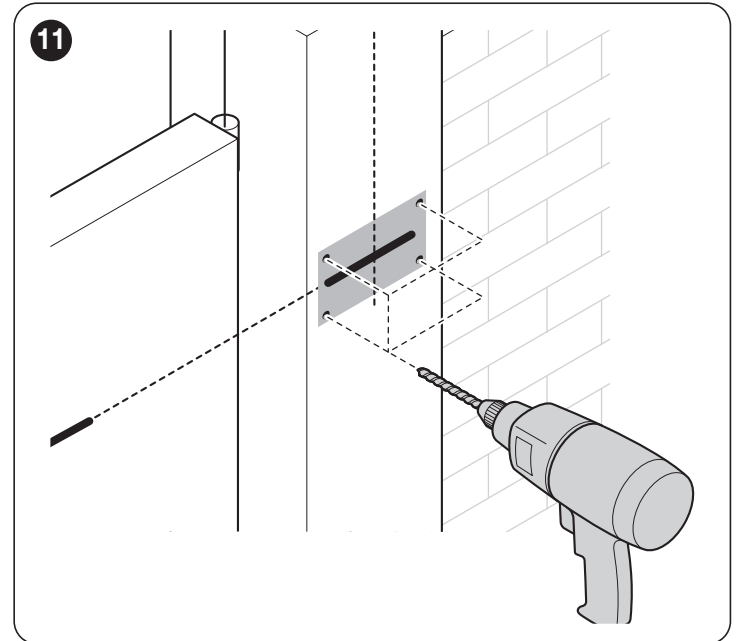

6. attach the fixing bracket (C) of the gearmotor to the wall using adequate wall plugs, screws and washers (not supplied)

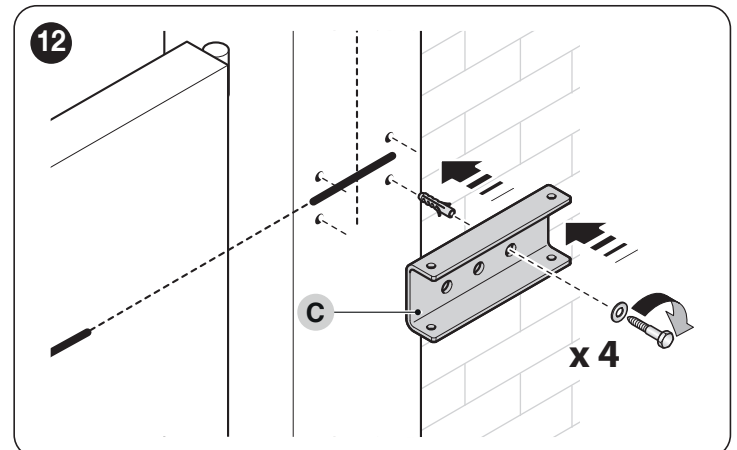

7. attach the gearmotor to the bracket using the two screws M4,8x13 (D) provided

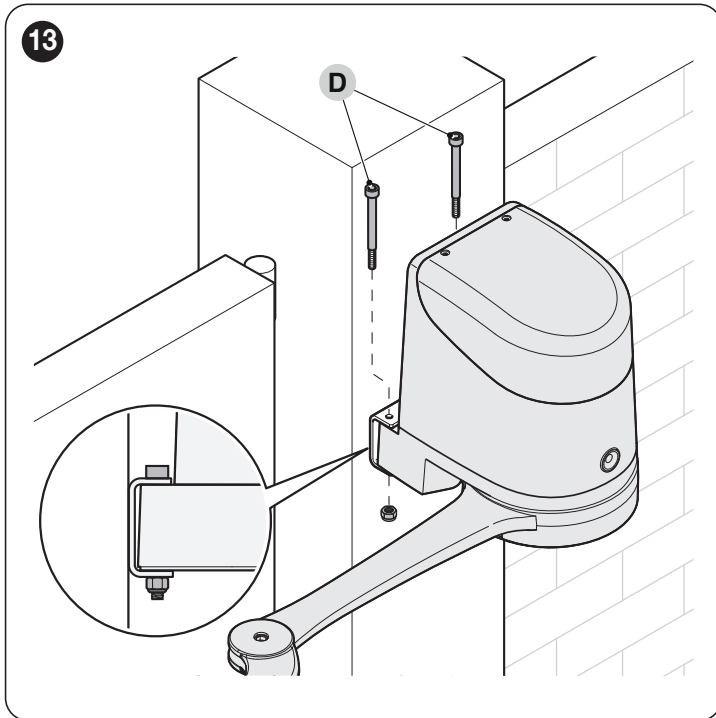

8. attach the curved arm (E) to the straight arm (F) using the pin (G) and retaining ring (H). likewise, attach the fixing bracket for the gate leaf (I) to the curved arm (E)

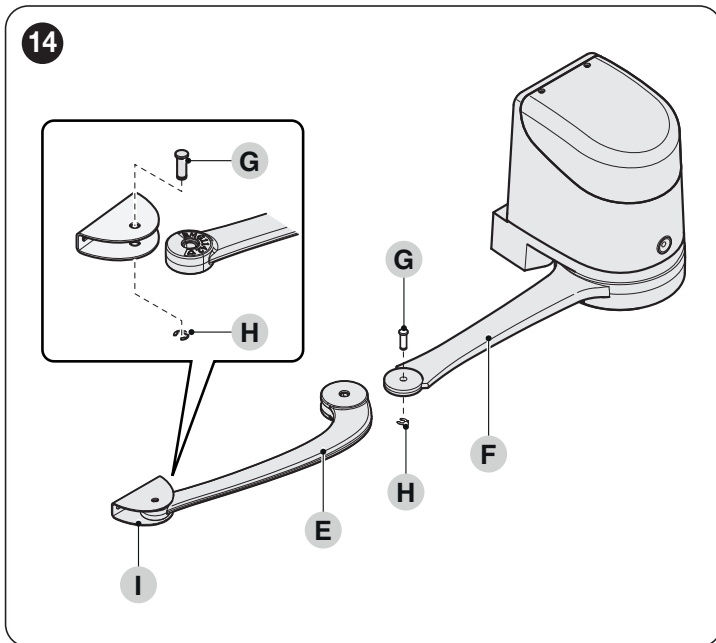

9. unlock the gearmotor manually (see paragraph "**Manually unlocking and locking the gearmotor**")
10. decide where to attach the bracket to the gate leaf, by extending the gearmotor arms as far as possible



It is important to position the bracket at the farthest point with respect to the position of the gearmotor.

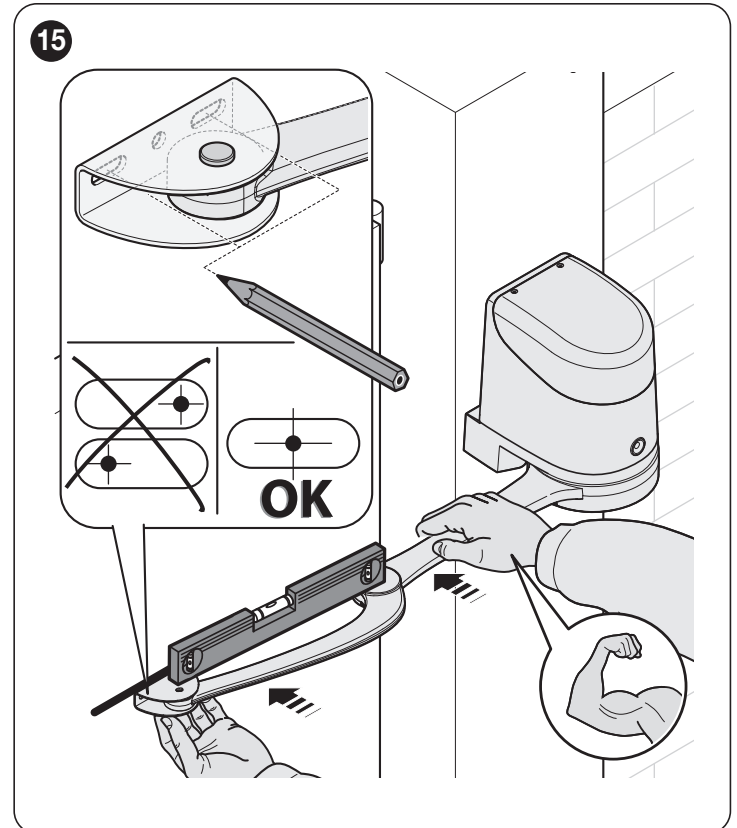

11. drill the leaf
12. separate the fixing bracket from the curved arm by removing the retaining ring and the relative pin

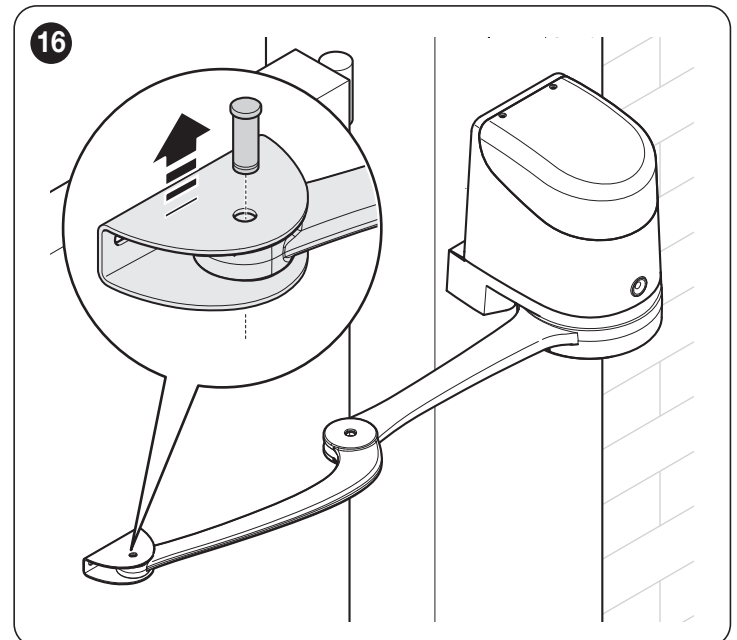

13. fasten the bracket to the gate leaf in the horizontal position, using adequate screws (not supplied)

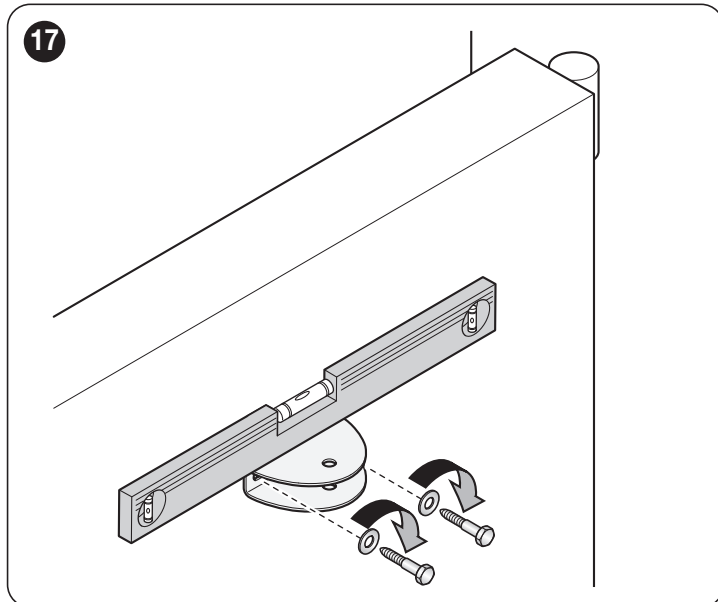

14. fasten the arm to the bracket again using the pin and retaining ring just removed
 15. before locking the gearmotor, adjust the limit switches (see paragraph "**Adjusting the mechanical limit switches**").

3.6 ADJUSTING THE MECHANICAL LIMIT SWITCHES

To adjust the limit switches, proceed as follows:

1. unlock the gearmotor with the relevant key provided (refer to the "**Manually unlocking and locking the gearmotor**" paragraph)
2. manually move the gate leaves to the fully open position
3. turn the plastic disc (A), located on the lower part of the gearmotor, moving the slot under the arm to the position shown

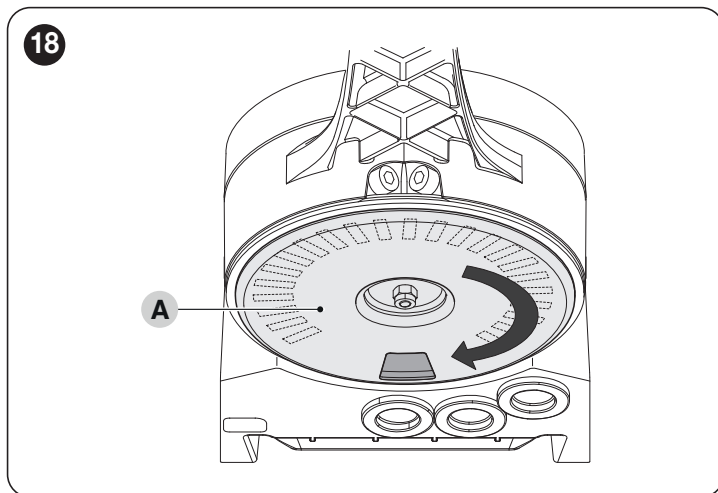

4. insert the limit switch (B) in the first available position: try inserting it as indicated

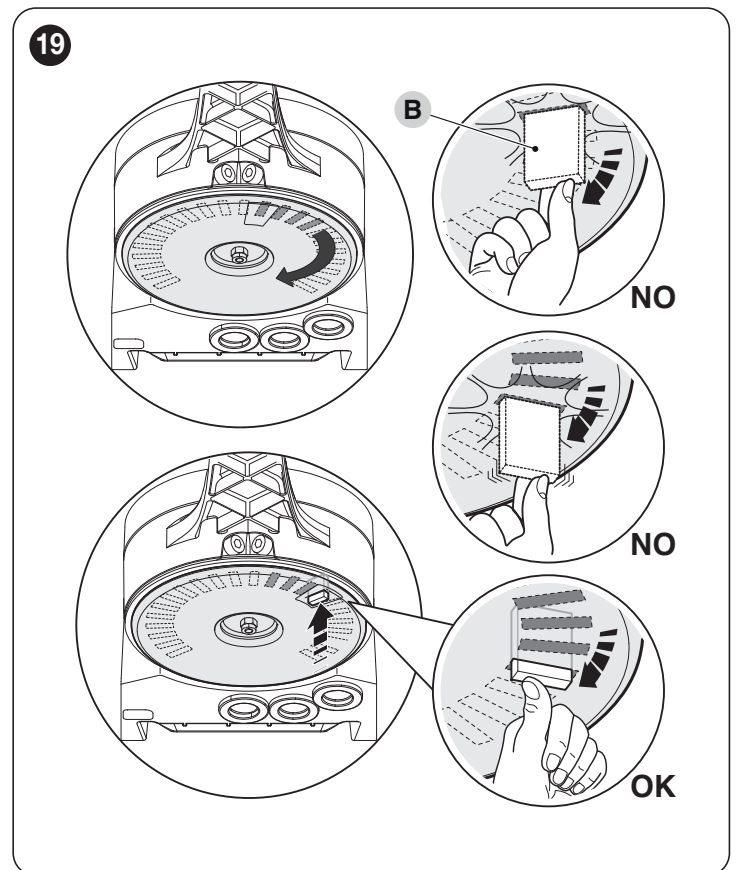

5. turn the disc (A) so that the limit switch does not fall and move the slot towards the position shown in "**Figure 18**". For a finer adjustment, turn the adjustment screw (C)

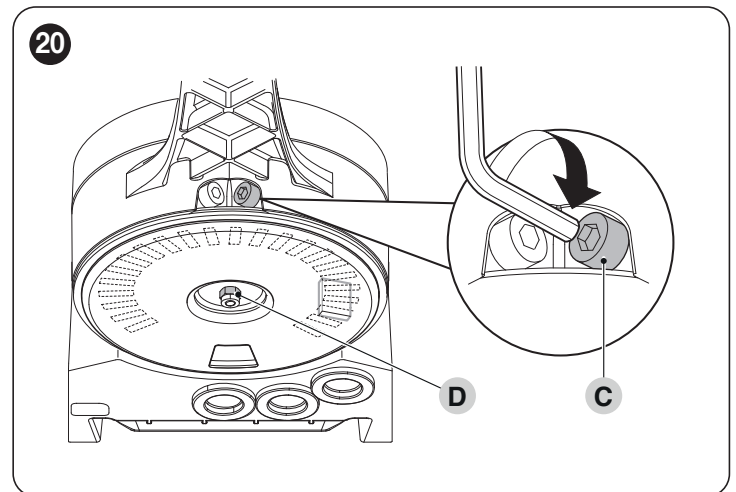

Hand icon: If the system has no closing stop on the ground, the entire procedure must be repeated to adjust the closing limit switch as well

6. fully tighten the nut fastening the disc (D) to prevent the latter from turning accidentally.

3.7 MANUALLY UNLOCKING AND LOCKING THE GEARMOTOR

The gearmotor is equipped with a mechanical unlocking device that can be used to open and close the gate manually. These manual operations should only be performed in case of a power outage, malfunctions or during the installation phases.

To unlock the device:

1. insert the key (A) and turn it clockwise by 180°

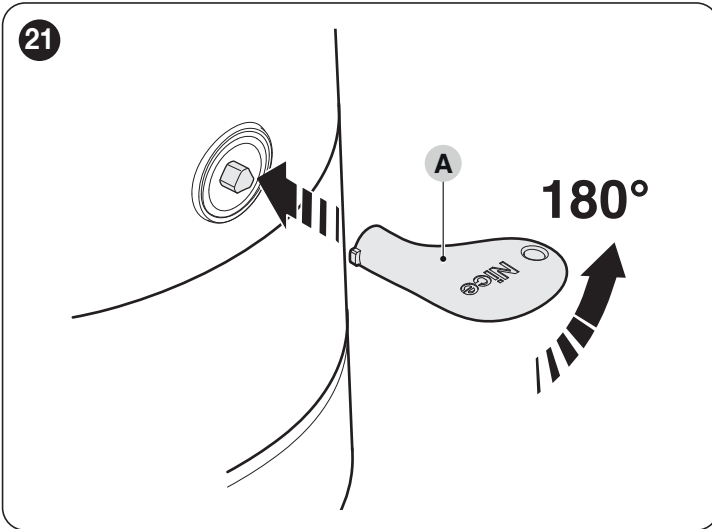

2. the gate leaf can now be moved manually to the desired position.

To lock the device:

1. turn the key (A) clockwise by 180°
2. remove the key.

4 ELECTRICAL CONNECTIONS

4.1 PRELIMINARY CHECKS



All electrical connections must be made with the system disconnected from the mains electricity and with the emergency power supply (if present in the automation) disconnected.



The connection operations must only be carried out by qualified personnel.



Mount a device on the electric power line that completely disconnects the automation from the grid.

- The disconnection device must have contacts with a sufficient gap to ensure complete disconnection, under the Category III overvoltage conditions, in accordance with the installation instructions.

To make the electrical connections:

1. open the gearmotor's cover (A)

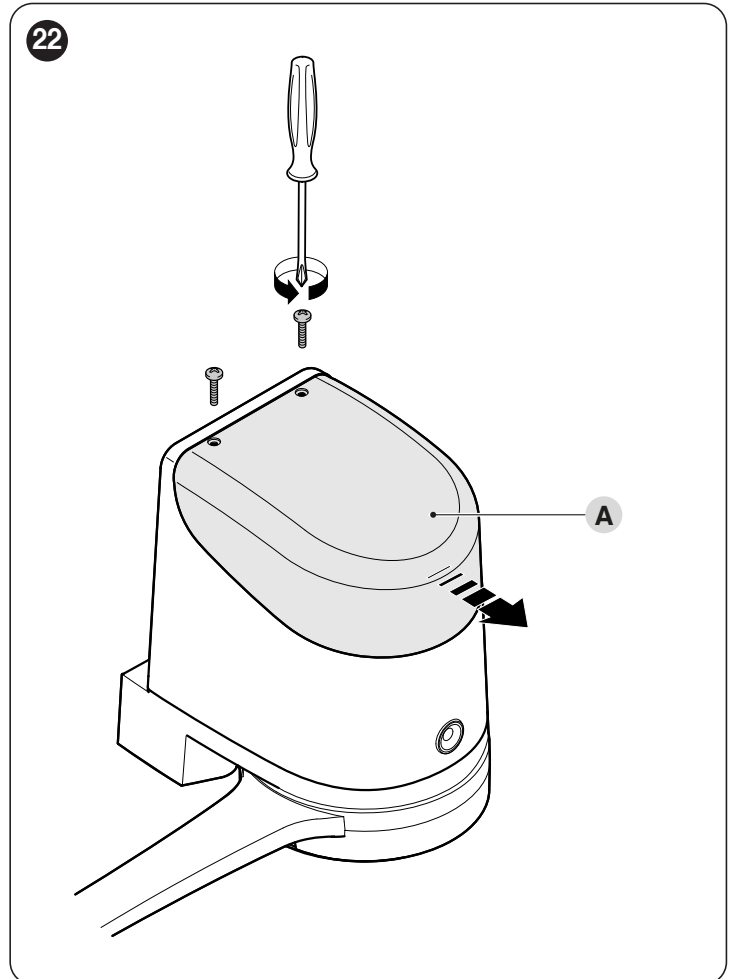

2. pass the power cable and the other electrical cables through the hole on the lower part of the gearmotor

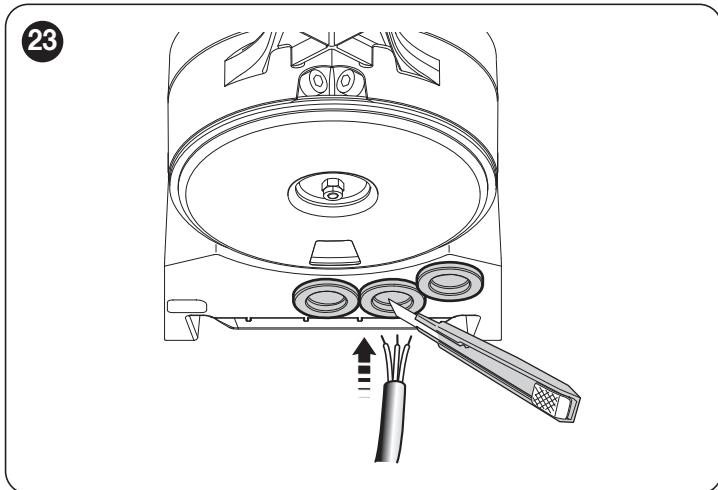

3. first connect the motor's power cable with the control unit **HO7124**: loosen the cable clamp **(B)**

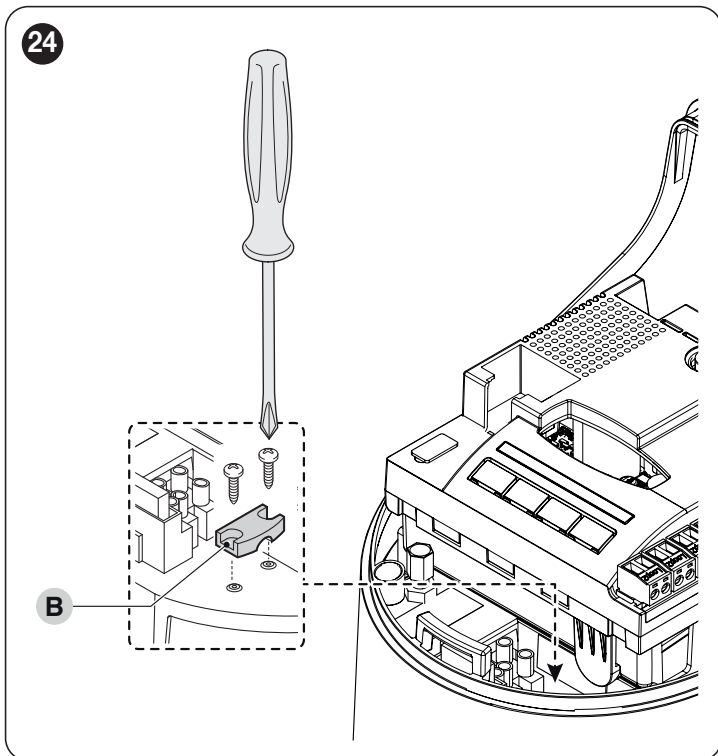

4. connect the power cable **(C)** and lock it in place with the cable clamp **(B)**

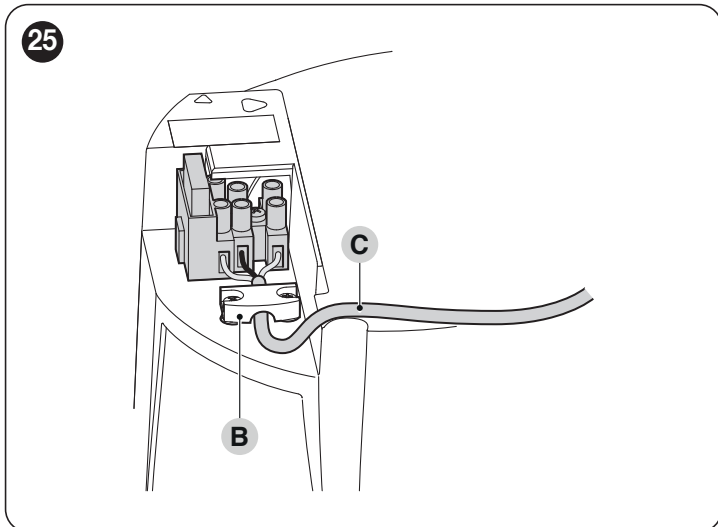

5. use the same procedure to connect the power cable to the motor without the control unit **HO7224**
6. connect the cables of any supplementary devices, by referring to **"Figure 27"** and to the **"Photocells"** paragraph
7. close the covers of the gearmotor.

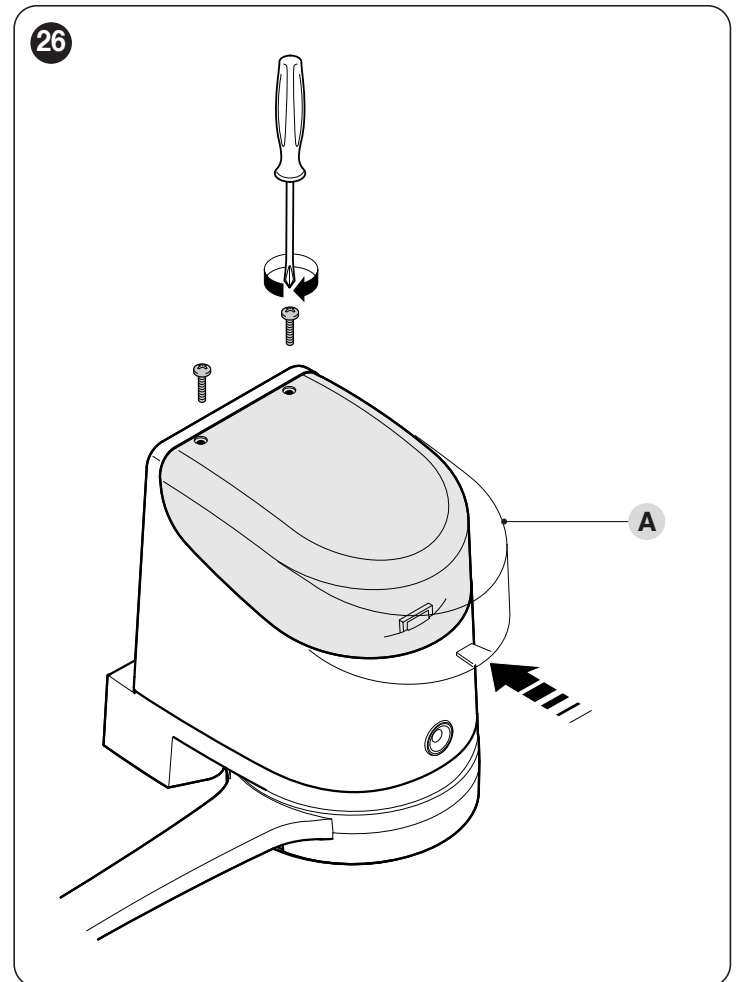

4.2 WIRING DIAGRAM AND DESCRIPTION OF CONNECTIONS

4.2.1 WIRING DIAGRAM

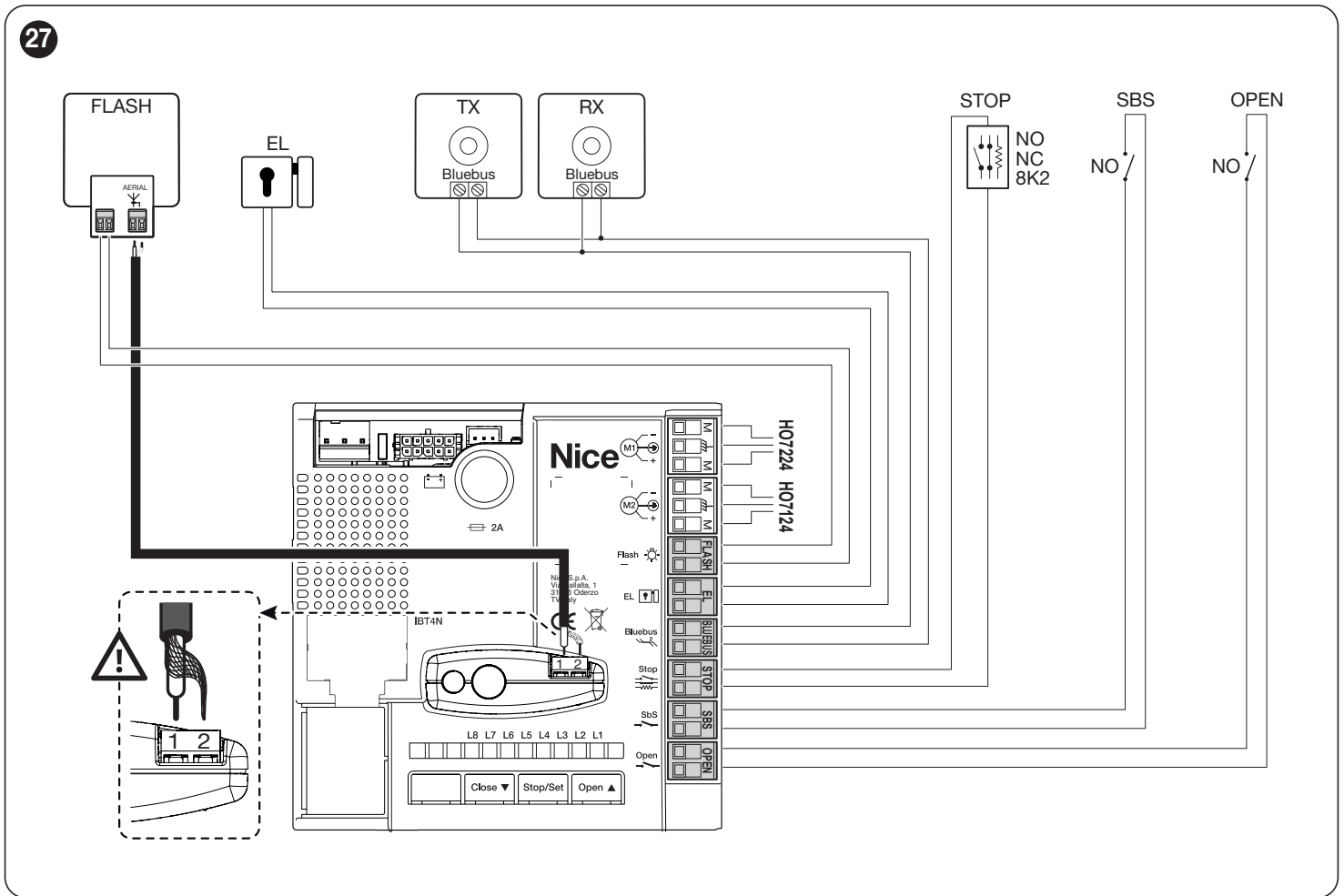

4.2.2 DESCRIPTION OF CONNECTIONS

Table 3

ELECTRICAL CONNECTIONS	
Terminals	Description
Flash	Output for 12 V (maximum 21 W) warning light or an ELDC warning light [Note 1]
EL	Output for 12 V~ (maximum 15 VA) electric lock [Note 1]
Bluebus	This terminal can be used to connect compatible devices, which are all connected in parallel with only two wires carrying both the electric power and communication signals. Example: EPM, EDSB, ETPB For further information on the BlueBUS, refer to the "BlueBUS" paragraph.
Stop	Input for devices that suspend or even stop the current manoeuvre; "Normally Closed" and "Normally Open" contacts or fixed resistor devices can be connected by suitably configuring the input. For further information on the STOP function, refer to the "STOP input" paragraph.
Sbs	Input for devices that control the movement in Step-by-Step mode; it is possible to connect "Normally Open" contacts.
Open	Input for devices that control the partial opening 1 movement; it is possible to connect "Normally Open" contacts.
M1	output for gearmotor without control unit (HO7224)
M2	output for gearmotor with control unit (HO7124)
1 - 2	inputs for antenna connection (on OXI receiver)

Note 1 Outputs "Flash" and "EL" can be programmed with other functions (see paragraph "Level 1 programming (ON-OFF)").

5 FINAL CHECKS AND START-UP

It is advisable to position the leaf approximately halfway along its path before starting the automation check and start-up phases, so that the leaf is free to open and close.

5.1 POWER SUPPLY CONNECTION

⚠ The power supply connections must only be made by qualified and experienced personnel possessing the necessary requirements and in full conformity to the laws, regulations and standards in force.

As soon as the product is powered, a few simple checks should be carried out:

1. check that the "BlueBUS" LED flashes regularly with one flash per second
2. check that the LEDs on the photocells (both the TX and RX) also flash; the type of flashing is irrelevant, since it depends on other factors
3. check that the warning light connected to the FLASH output is off.

If the above conditions are not satisfied, immediately switch off the power supply to the control unit and carefully check the electrical connections. Further useful information on searching and diagnosing faults is included in the "TROUBLESHOOTING GUIDE" chapter.

5.2 DEVICE LEARNING

Once the power supply has been connected, the control unit must recognise the devices connected to the "BlueBUS" and "STOP" inputs. Prior to this phase, LEDs "L1" and "L2" will flash to signal that the device learning procedure must be performed.

✋ The learning phase must be carried out even if no device is connected to the control unit.

To do this:

1. simultaneously press and hold the [Open ▲] and [Stop/Set] buttons
2. release the buttons when LEDs "L1" and "L2" start flashing quickly (after roughly 3 seconds)
3. wait a few seconds until the control unit has completed the device learning phase
4. once this phase terminates, the "Stop" LED must be lit and LEDs "L1" and "L2" must switch off (LEDs "L3" and "L4" could start flashing).

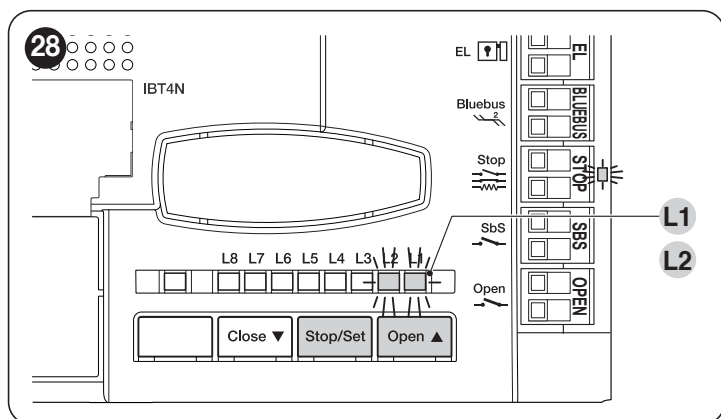

The learning process of connected devices can be repeated at any time, even after the installation (for example, whenever a device must be added); to complete the new learning process, refer to the "Learning of other devices" paragraph.

5.3 LEARNING OF THE MECHANICAL STOP POSITIONS

Once the connected devices have been learned, the mechanical stop positions must be learned (maximum opening and maximum closing). This procedure can be carried out in three different ways: **automatic**, **manual** and **mixed**.

In the **automatic** mode, the control unit learns the mechanical stops and calculates the most appropriate offsets for the "SA" and "SC" doors ("Figure 29").

⚠ Before starting the self-learning procedure in automatic mode, verify that the motor force is suited to the type of motor being used (see paragraph "Level 2 programming (adjustable parameters) - Function L5").

In the **manual** mode, the positions ("Figure 29") are programmed one by one, by shifting the leaves to the desired points. The position to be programmed is signalled when one of the six LEDs "L1...L6" flashes (see "Table 4").

In the **mixed** mode, it is possible to perform the automatic procedure and then, with the manual procedure, modify one or more positions with the exception of the "0" and "1" positions ("Figure 29") which correspond to the mechanical stop positions.

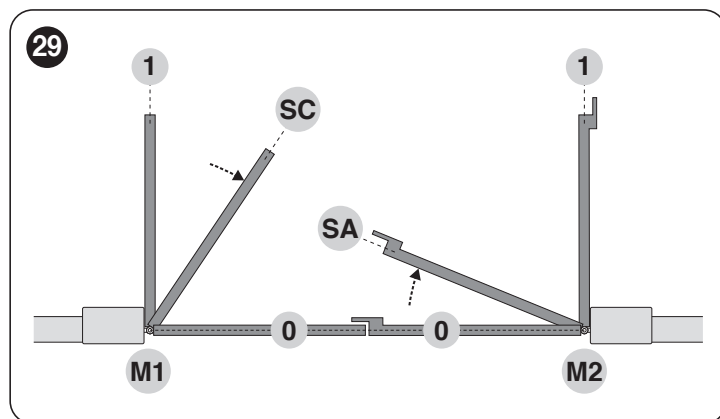
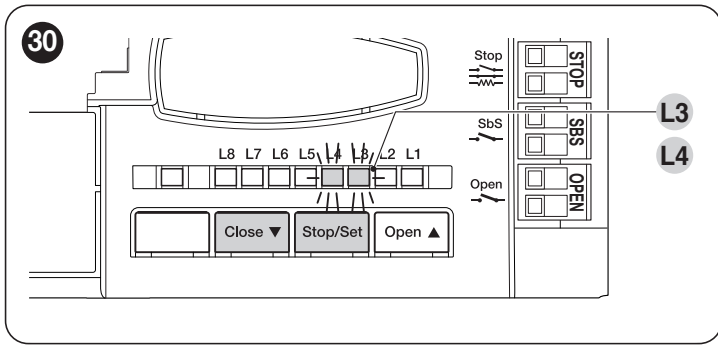

Table 4

PROGRAMMING POSITIONS		
Position	LED	Description
Position 0 (motor 1)	L1	maximum closing position: when the leaf relative to motor 1 strikes the closing mechanical stop
Position 0 (motor 2)	L2	maximum closing position: when the leaf relative to motor 2 strikes the closing mechanical stop
Position SA (motor 2)	L3	Position after which the leaf relative to motor 1 starts opening
Position SC (motor 1)	L4	Position after which the leaf relative to motor 2 starts closing
Position 1 (motor 1)	L5	Maximum opening position: when the leaf relative to motor 1 strikes the opening mechanical stop
Position 1 (motor 2)	L6	Maximum opening position: when the leaf relative to motor 2 strikes the opening mechanical stop

5.3.1 LEARNING IN AUTOMATIC MODE



To effect the automatic learning procedure:

1. simultaneously press and hold the and **[Stop/Set]** buttons **[Close ▼]**
2. release the buttons when LEDs “L3” and “L4” start flashing quickly (after roughly 3 seconds)
3. check that the automation carries out the following manoeuvre sequences:
 - a. closing of motor M1 up to the mechanical stop
 - b. closing of motor M2 up to the mechanical stop
 - c. opening of motors M1 and M2 up to the mechanical stop
 - d. fast closing of motors M1 and M2.



If the first two manoeuvres (a and b) are not “closing” but “opening” manoeuvres, press the [Open ▲] or [Close ▼] button to stop the learning phase. At this point, invert the control wires (external positions with respect to the terminal) on the motor that executed the opening manoeuvre and repeat the self-learning procedure.



If the first “closing” manoeuvre is not commanded by motor M1, press the [Open ▲] or [Close ▼] button to stop the learning phase. At this point, switch the M1 and M2 terminals on the control unit and repeat the self-learning procedure.

4. at the end of the closing manoeuvre (d) of the two motors, LEDs “L3” and “L4” switch off to signal that the procedure was performed correctly.



If, during the automatic learning procedure, the photo-cells or one of the devices connected to the “stop” input intervene, the procedure interrupts and LED L1 starts flashing. In this case, the self-learning procedure must be repeated from the beginning.



The automatic learning procedure can be run again at any time, even after the installation phase; for example, after modifying the position of the mechanical stops.

5.3.2 LEARNING IN MANUAL MODE



The user has maximum 10 seconds to press the buttons consecutively during the learning procedure. After this time, the procedure terminates automatically and memorises the changes made up to that time.



When LEDs “L1..L6” flash, to shift between LEDs simply press the [Open ▲] or [Close ▼] button briefly (the LED will flash to signal the current position).

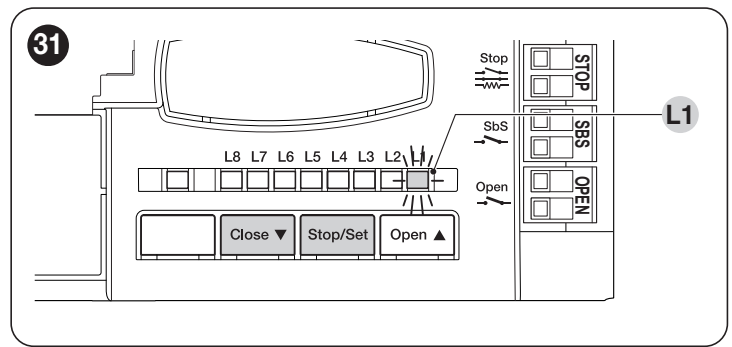

To effect the manual learning procedure:

1. simultaneously press and hold the and **[Stop/Set]** buttons **[Close ▼]**
2. release the buttons when LED “L1” starts flashing (after roughly 1 second)
3. LED “L1” flashes: **position 0 of M1**
 - to command and move motor 1 to **position “0”** (“Figure 31”): press and hold the **[Open ▲]** o **[Close ▼]** button. Once the position is reached, release the button to stop the manoeuvre
 - to memorise the position, press and hold the **[Stop/Set]** button for at least 3 seconds then release it (after 2 seconds LED “L1” will remain lit and after the **[Stop/Set]** button is released, LED “L2” will start flashing)
4. LED “L2” flashes: **position 0 of M2**
 - to command and move motor 2 to **position “0”** (“Figure 31”): press and hold the **[Open ▲]** o **[Close ▼]** button. Once the position is reached, release the button to stop the manoeuvre
 - to memorise the position, press and hold the **[Stop/Set]** button for at least 3 seconds then release it (after 2 seconds LED “L2” will remain lit and after the **[Stop/Set]** button is released, LED “L3” will start flashing)
5. LED “L3” flashes: **position SA of M2**
 - to command and move motor 2 to **position “SA”** (“Figure 31”): press and hold the **[Open ▲]** o **[Close ▼]** button. Once the position is reached, release the button to stop the manoeuvre
 - to memorise the position, press and hold the **[Stop/Set]** button for at least 3 seconds then release it (after 2 seconds LED “L3” will remain lit and after the **[Stop/Set]** button is released, LED “L4” will start flashing)
6. LED “L4” flashes: **position SC of M1**
 - to command and move motor 1 to **position “SC”** (“Figure 31”): press and hold the **[Open ▲]** o **[Close ▼]** button. Once the position is reached, release the button to stop the manoeuvre
 - to memorise the position, press and hold the **[Stop/Set]** button for at least 3 seconds then release it (after 2 seconds LED “L4” will remain lit and after the **[Stop/Set]** button is released, LED “L5” will start flashing)
7. LED “L5” flashes: **position 1 of M1**
 - to command and move motor 1 to **position “1”** (“Figure 31”): press and hold the **[Open ▲]** o **[Close ▼]** button. Once the position is reached, release the button to stop the manoeuvre
 - to memorise the position, press and hold the **[Stop/Set]** button for at least 3 seconds then release it (after 2 seconds LED “L5” will remain lit and after the **[Stop/Set]** button is released, LED “L6” will start flashing)

8. LED "L6" flashes: **position 1 of M2**
- to command and move motor 2 to **position "1"** ("Figure 31"); press and hold the [Open ▲] or [Close ▼] button. Once the position is reached, release the button to stop the manoeuvre
 - to memorise the position, press and hold the [Stop/Set] button for at least 3 seconds then release it (after 2 seconds LED "L6" will remain lit until the [Stop/Set] button is released).



If the system has a single motor only:

- run the manual learning procedure described above up to point 2
- programme the position relative to LED "L1" as described under point 3
- briefly press the [Open ▲] or [Close ▼] buttons until LED "L5" flashes
- programme the position relative to LED "L5" as described under point 7.

DO NOT PROGRAMME the positions relative to LEDs "L3" (SA of M2) and "L4" (SC of M1). To shift between the various positions, simply press the [Open ▲] or [Close ▼] button briefly until the desired LED flashes.

5.3.3 LEARNING IN MIXED MODE



The user has maximum 10 seconds to press the buttons consecutively during the learning procedure. After this time, the procedure terminates automatically and memorises the changes made up to that time.

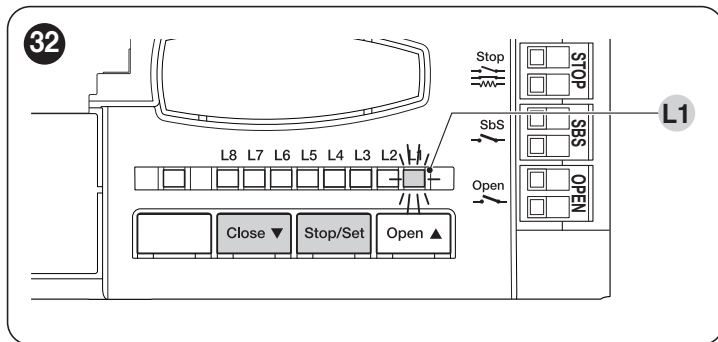

To effect the learning procedure in mixed mode:

1. run the self-learning procedure in automatic mode as described under the "Learning in automatic mode" paragraph
2. simultaneously press and hold the and [Stop/Set] buttons [Close ▼]
3. release the buttons when LED "L1" starts flashing
4. briefly press the [Open ▲] or [Close ▼] button to shift the flashing LED (L1...L6) to the position to be programmed
5. proceed for each individual position, as described in the "Learning in manual mode" paragraph
6. repeat this last operation for all the other positions to be modified.

5.4 CHECKING THE GATE MOVEMENT

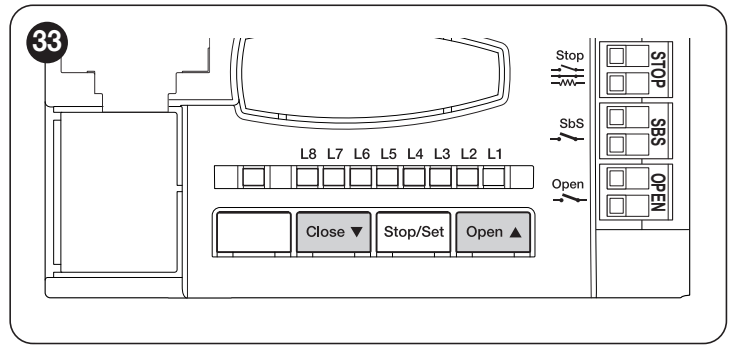

At the end of the learning phase, we recommend letting the control unit run a few opening and closing manoeuvres to verify whether the gate moves correctly and if there are any assembly and adjustment defects.

To do this:

1. press the [Open ▲] button to command an "Open" manoeuvre; check that the acceleration, constant-speed and slowdown phases are present during the opening manoeuvre. Once the manoeuvre terminates, the gate leaves must stop a few centimetres from the opening mechanical stop
2. press the [Close ▼] button to command a "Close" manoeuvre; check that the acceleration, constant-speed and slowdown phases are present during the closing manoeuvre. Once the manoeuvre terminates, the gate leaves must be perfectly closed on the closing mechanical stop
3. open and close the gate several times to make sure that there are no points of excessive friction and that there are no defects in the assembly or adjustments
4. check that all previously adjusted functions have been learned by the control unit.

5.5 CONNECTING OTHER DEVICES

If the user needs to power external devices, such as a proximity reader for transponder cards or the light of the key selector switch, power can be tapped as shown in the figure.

The power supply voltage is 24V \pm -30% ÷ +50% with a maximum available current of 200mA.



WARNING

In Stand-By mode, the power supply drops to 21V \pm +/- 10% with an available power of 2W.

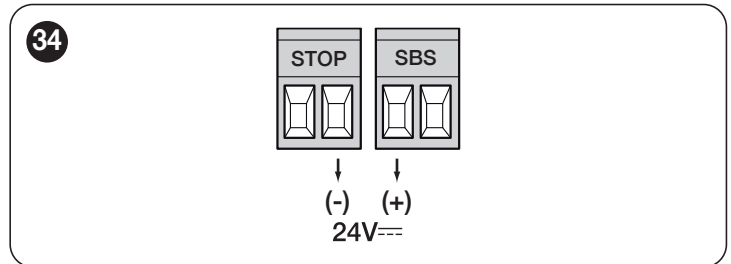

The voltage available at the "SbS" and "STOP" terminals remains even when the "Stand-by" function is enabled on the board.

6 TESTING AND COMMISSIONING

These are the most important phases of the automation's construction, as they ensure maximum safety of the system. The test can also be used to periodically verify the devices making up the automation.

 **Testing and commissioning of the automation must be performed by skilled and qualified personnel, who are responsible for the tests required to verify the solutions adopted according to the risks present, and for ensuring that all legal provisions, standards and regulations are met, in particular all the requirements of the EN 12445 standard, which defines the test methods for checking gate automations.**

The additional devices must undergo specific testing, both in terms of their functions and their proper interaction with the control unit. Refer to the instruction manuals of the individual devices.

6.1 TESTING

To run the test:

1. verify that all the instructions stated in the "**GENERAL SAFETY WARNINGS AND PRECAUTIONS**" chapter (page 3) have been strictly observed
2. unlock the gearmotor as indicated in the "**Manually unlocking and locking the gearmotor**" paragraph
3. make sure that the leaf can be moved manually during both the opening and closing phases with a force not exceeding 390N (roughly 40 kg)
4. lock the gearmotor
5. using the control devices (transmitter, control button, key selector, etc.), test the gate's opening, closing and stoppage movements to make sure that the leaves move as intended. Several tests should be carried out to assess the movement of the leaves and detect any defects in the installation and adjustment, besides any points of excessive friction
6. check, one-by-one, that all safety devices mounted on the system (photocells, sensitive edges, etc.) work properly. Each time a device intervenes, the "**Bluebus**" LED on the control unit will emit two faster flashes to confirm the recognition
7. if potentially dangerous situations due to the movement of the leaves have been prevented by limiting the impact force, the latter must be measured according to the EN 12445 standard and, if the "motor force" control is used to aid the system in reducing the impact force, it is necessary to test various adjustments to find the one that gives the best results.

6.2 COMMISSIONING

 **Commissioning can only be performed after all testing phases have been successfully completed.**

 **Before commissioning the automation, ensure that the owner is properly informed of all residual risks and hazards.**

 **The gate cannot be commissioned partially or under "temporary" conditions.**

To commission the automation:

1. compile the automation's technical file, which must include the following documents: overall drawing of the automation, wiring diagram, risk assessment and relative solutions adopted, the manufacturer's declaration of conformity for all devices used and the declaration of conformity compiled by the installer
2. affix a permanent label or sign near the gate specifying the operations for unlocking the gate and manoeuvring it manually "**Figure 35**"

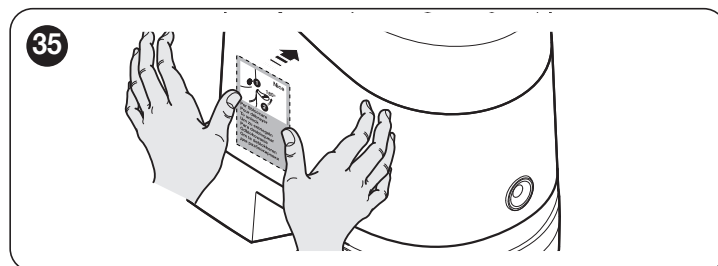

3. affix a data plate on the gate specifying at least the following data: type of automation, name and address of the manufacturer (responsible for commissioning), serial number, year of manufacture and CE mark
4. compile the declaration of conformity of the automation and hand it to the owner of the automation
5. compile the User Manual of the automation and hand it to the owner of the automation
6. compile and provide the owner with the automation's "Maintenance schedule", containing the maintenance instructions for all the automation's devices.



For all the above-mentioned documentation, Nice – through its technical assistance service – provides the following: instruction manuals and guides.

7 PROGRAMMING

There are 3 buttons on the control unit: **[Open ▲]**, **[Stop/Set]** and **[Close ▼]** ("**Figure 36**") which can be used both for commanding the control unit during the testing phase and to programme the available functions.

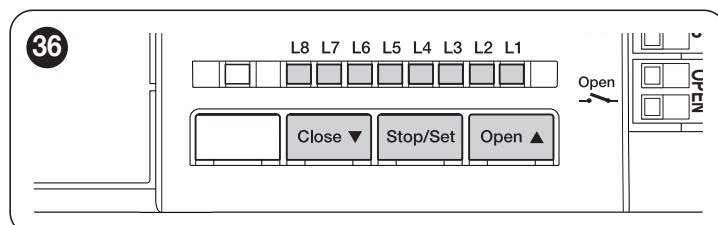

The available programmable functions are grouped into **two levels** and their operating status is signalled by eight LEDs "**L1 ... L8**" located on the control unit (LED lit = function enabled; LED off = function disabled).

7.1 USING THE PROGRAMMING BUTTONS

[Open ▲] Button for commanding the gate opening
Selection button during the programming phase.

[Stop/Set] Button used to stop a manoeuvre
If pressed for more than 5 seconds, it allows for entering the programming mode.

[Close ▼] Button for commanding the gate's closure
Selection button during the programming phase.

7.2 LEVEL 1 PROGRAMMING (ON-OFF)

All the Level 1 functions are factory-set to “OFF” and can be modified at any time. To check the various functions, refer to “Table 5”.

7.2.1 LEVEL 1 PROGRAMMING PROCEDURE



The user has maximum 20 seconds to press the buttons consecutively during the programming procedure. After this time, the procedure terminates automatically and memorises the changes made up to that time.

To perform Level 1 programming:

1. press and hold the [Stop/Set] button until LED “L1” starts flashing
2. release the [Stop/Set] button when LED “L1” starts flashing
3. press the [Open ▲] or [Close ▼] button to move the flashing LED to the LED associated with the function to be modified
4. press the [Stop/Set] button to change the status of the function:
 - short flash = OFF
 - long flash = ON
5. wait 10 seconds (maximum time) to exit the programming mode.



To set other functions to “ON” or “OFF”, while the procedure is running, repeat points 2 and 3 during the phase itself.

Table 5

LEVEL 1 FUNCTIONS (ON-OFF)		
LED	Function	Description
L1	Automatic closing	Function ENABLED: after an opening manoeuvre there is a pause (equal to the set pause time), after which the control unit automatically starts a closing manoeuvre. The pause time is set by default to 30 seconds. Function NOT ENABLED: the system works in “semi-automatic” mode. Warning Adjust the standby mode entry time to be longer than the automatic closing time.
L2	Close after photo	Function ENABLED: the behaviour changes depending on whether the “Automatic Closing” function is enabled or not. With “Automatic closing enabled”, if during the opening or closing manoeuvre the photocells (Photo or Photo 1) intervene, the pause time drops to 5 seconds, regardless of the programmed pause time. With “Automatic closing not enabled”, if during the closing manoeuvre the photocells (Photo or Photo 1) intervene, the “Automatic Closing” activates with the programmed pause time. Function DISABLED: the pause time is that which has been programmed or automatic re-closing will not take place if the function is disabled.
L3	Always Close	Function ENABLED: in the event of a blackout, even of short duration, if the control unit detects that the gate is not closed once the electricity is restored, it automatically starts a closing manoeuvre, preceded by a 5-second pre-flashing sequence. Function NOT ENABLED: once the electricity is restored, the gate remains where it was.
L4	Stand-by	This function allows for minimising consumption and is particularly useful in cases when the back-up battery is used. If this function is active, after 5 minutes from the end of the operation, the control unit turns off the Bluebus photocell transmitters and all LEDs, except for the Bluebus LED which will blink more slowly. When a command is received, the control unit restores full operation. Warning The factory setting enables the standby function. It can only be disabled by the user, with the understanding that power consumption will increase when the product is not performing the function of moving the gate.
L5	Electric lock / Courtesy light	Function ENABLED: the “electric lock” output switches its operation to “courtesy light”. Function NOT ENABLED: the output functions as an electric lock.
L6	Pre-flashing	Function ENABLED: a 3-second pause can be added between the switching on of the warning light and the start of the manoeuvre, to warn the user in advance of a potentially dangerous situation. Function DISABLED: the signalling of the warning light coincides with the start of the manoeuvre.
L7	“SbS” turns into “Open” and “Open” into “Close”	Function ENABLED: the “SbS” and “Open” inputs of the control unit function as “Open” and “Close” commands. Function NOT ENABLED: the “SbS” and “Open” inputs of the control unit function as “Step-by-Step” and “Partial open 1” commands.
L8	“Flash” or “Open gate indicator”	Function ENABLED: the “Flash” output of the control unit switches its operation to “Gate open indicator”. Function NOT ENABLED: the “Flash” output of the control unit performs the “Warning light” function.



During normal operation, LEDs “L1 ... L8” are on/off depending on the status of the respective function; for example, “L1” is lit when the “Automatic Closing” function is enabled.

7.3 LEVEL 2 PROGRAMMING (ADJUSTABLE PARAMETERS)

All the Level 2 parameters are factory-set as highlighted in "GREY" in "Table 6" and can be modified at any time. The parameters can be set to a scale of 1 to 8. The check the value corresponding to each LED, refer to "Table 6".

7.3.1 LEVEL 2 PROGRAMMING PROCEDURE



The user has maximum 20 seconds to press the buttons consecutively during the programming procedure. After this time, the procedure terminates automatically and memorises the changes made up to that time.

To perform Level 2 programming:

1. press and hold the [Stop/Set] button until LED "L1" starts flashing
2. release the [Stop/Set] button when LED "L1" starts flashing
3. press the [Open ▲] or [Close ▼] button to move the flashing LED to the "entry LED" associated with the parameter to be modified
4. press and hold the [Stop/Set] button. With the [Stop/Set] button pressed:
 - wait roughly 3 seconds, until the LED representing the current level of the parameter to be modified lights up
 - press the [Open ▲] or [Close ▼] button to shift the LED associated with the parameter's value
5. release the [Stop/Set] button
6. wait 10 seconds (maximum time) to exit the programming mode.



To set multiple parameters during the procedure's execution, repeat the operations from point 2 to point 4 during the phase itself.



The set value highlighted in grey ("Table 6") indicates that this value is the factory setting.

Table 6

LEVEL 2 FUNCTIONS (ADJUSTABLE PARAMETERS)				
Entry LED	Parameter	LED (level)	Set value	Description
L1*	Pause Time	L1	5 seconds	Adjusts the pause time, i.e. the time before automatic re-closure. Is effective only if "Automatic Closing" is enabled.
		L2	15 seconds	
		L3	30 seconds	
		L4	45 seconds	
		L5	60 seconds	
		L6	80 seconds	
		L7	120 seconds	
		L8	180 seconds	
L2	Step-by-Step function	L1	Open - Stop - Close - Stop	Controls the sequence of commands associated with the "SbS", "Open" and "Close" inputs or the radio control. [Note :] by setting L4, L5, L7 and L8, also the behaviour of the "Open" and "Close" commands is modified.
		L2	Open - Stop - Close - Open	
		L3	Open - Close - Open - Close	
		L4	Condominium: during the opening manoeuvre the "Step-by-Step" and "Open" commands do not cause any effect, while the "Close" command causes the movement to reverse, namely closing of the leaves; during the closing manoeuvre the "Step-by-Step" and "Open" commands cause the movement to reverse, namely opening of the leaves, while the "Close" command does not cause any effect.	
		L5	Condominium 2: during the opening manoeuvre the "Step-by-Step" and "Open" commands do not cause any effect, while the "Close" command causes the movement to reverse, namely closing of the gate leaves. If the sent command remains for more than 2 seconds, a "Stop" command is executed. During the closing manoeuvre the "Step-by-Step" and "Open" commands cause the movement to reverse, namely opening of the leaves, while the "Close" command does not cause any effect. If the sent command remains for more than 2 seconds, a "Stop" command is executed.	
		L6	Step-by-Step 2 (less than 2 sec triggers "Partial Open")	
		L7	Hold-to-run: the manoeuvre is only executed if the sent command remains; if it is interrupted, the manoeuvre stops.	
		L8	Opening in "semi-automatic" mode, closing in "hold-to-run" mode	
L3	Motor speed	L1	Very slow	Adjusts the motor speed during normal manoeuvres.
		L2	Slow	
		L3	Medium	
		L4	Fast	
		L5	Very fast	
		L6	Extremely fast	
		L7	Opens "Fast"; closes "Slow"	
		L8	Opens "Extremely fast"; closes "Medium"	

LEVEL 2 FUNCTIONS (ADJUSTABLE PARAMETERS)				
Entry LED	Parameter	LED (level)	Description	
L4	Motor discharge after closing	L1	No discharge	Adjusts the duration of the “brief reversal” of both motors, once the closing manoeuvre terminates, to reduce the residual final thrust.
		L2	Level 1 - Minimum discharge (roughly 100 ms)	
		L3	Level 2 - ...	
		L4	Level 3 - ...	
		L5	Level 4 - ...	
		L6	Level 5 - ...	
		L7	Level 6 - ...	
		L8	Level 7 - Maximum discharge (roughly 1 s)	
L5	Motor force	L1	Level 1 - Minimum force	Adjusts the force of both motors.
		L2	Level 2 - ...	
		L3	Level 3 - ...	
		L4	Level 4 - ...	
		L5	Level 5 - ...	
		L6	Level 6 - ...	
		L7	Level 7 - ...	
		L8	Level 8 - Maximum force	
L6	Pedestrian or partial opening	L1	Pedestrian 1 (the M2 gate leaf opens to 1/4 of the full range)	Adjusts the type of opening associated with the “partial opening 1” command. [Note :] “minimum” opening refers to the smallest opening between M1 and M2; for example, if M1 opens to 90° and M2 opens to 110°, the minimum opening is 90°.
		L2	Pedestrian 2 (the M2 gate leaf opens to 1/2 of the full range)	
		L3	Pedestrian 3 (the M2 gate leaf opens to 3/4 of the full range)	
		L4	Pedestrian 4 (full opening of gate leaf M2)	
		L5	Partial 1 (the two gate leaves open to 1/4 of the “minimum” range)	
		L6	Partial 2 (the two gate leaves open to 1/2 of the “minimum” range)	
		L7	Partial 3 (the two gate leaves open to 3/4 of the “minimum” range)	
		L8	Partial 4 (the two gate leaves open to the “minimum” range)	
L7*	Maintenance notice	L1	500	Adjusts the number of manoeuvres after which the automation maintenance request is triggered (see the “ Maintenance notice ” function” paragraph).
		L2	1000	
		L3	1500	
		L4	2500	
		L5	5000	
		L6	10000	
		L7	15000	
		L8	20000	
L8	List of malfunctions	L1	Result of 1st manoeuvre (most recent)	Allows for checking the type of anomaly that occurred in the last 8 manoeuvres (see the “ Anomaly log ” paragraph).
		L2	Result of 2nd manoeuvre	
		L3	Result of 3rd manoeuvre	
		L4	Result of 4th manoeuvre	
		L5	Result of 5th manoeuvre	
		L6	Result of 6th manoeuvre	
		L7	Result of 7th manoeuvre	
		L8	Result of 8th manoeuvre	

(*) If the value of a parameter falls between two adjacent values, the control unit will switch on intermittently the two LEDs identifying the value itself. If necessary, the values can be rounded off by pressing the **[Open ▲]** or **[Close ▼]** button to round off respectively to the higher or lower value among the two values highlighted by the control unit.

Example: Maintenance warning = 7000 manoeuvres - LEDs L5 and L6 flash. Pressing the **[Close ▼]** button rounds off to value L5 (5000), while pressing the **[Open ▲]** button rounds off to value L6 (10000).

If the value of a parameter is below the minimum value or above the maximum value among those listed in the table, the control unit will switch on intermittently LED L1 or L8 respectively. If necessary, the values can be rounded off by pressing the **[Open ▲]** or **[Close ▼]** button to round off to the nearest value.

Example: Pause Time = 1 seconds - LED L1 will flash. Pressing the **[Open ▲]** button rounds off to value L1 (5 s) and L1 will no longer flash because the parameter will have been rounded off to a known value.

7.4 SPECIAL FUNCTIONS

7.4.1 “MOVE ANYWAY” FUNCTION

This function can be used to operate the automation even one or more safety devices fail to work properly or are out of order. The automation can be controlled in “**hold-to-run**” mode by proceeding as follows:

1. send a command to operate the gate, using a transmitter or key selector, etc. If everything functions properly, the gate will move normally, otherwise proceed with point 2
2. within 3 seconds, press the control again and hold it down
3. after roughly 2 seconds, the gate will complete the requested manoeuvre in “**hold-to-run**” mode, in other words, it will continue to move so long as the control is held down.



When the safety devices fail to work, the flashing indicator will flash a few times to signal the type of problem. To verify the type of anomaly, consult the “*Signalling through warning light*” chapter (page 22).

7.4.2 “MAINTENANCE NOTICE” FUNCTION

This function notifies the user when the automation needs a maintenance check. The number of manoeuvres after which the signal is triggered can be selected among 8 levels, through the “**Maintenance notice**” adjustable parameter (see paragraph “*Level 2 programming (adjustable parameters)*”).

The maintenance request signal is given through a lamp connected to the “Flash” or “EL” output, when one of these two outputs is programmed – with the Oview programmer – as a “**Maintenance Indicator**” (see paragraph “*Level 2 programming (adjustable parameters)*”).



The maintenance indicator emits the signals shown in “*Table 7*” based on the number of manoeuvres completed with respect to the set limit.

Table 7

MAINTENANCE NOTICE THROUGH FLASH AND MAINTENANCE INDICATOR	
Number of manoeuvres	Maintenance indicator signal
Below 80% of the limit	Lit for 2 seconds at the start of the opening manoeuvre
Between 81% and 100% of the limit	Flashes for the entire duration of the manoeuvre
Exceeding 100% of the limit	Flashes always

7.4.3 VERIFYING THE NUMBER OF MANOEUVRES COMPLETED

The “**Maintenance notice**” function can be used to verify the number of manoeuvres completed as a percentage of the set limit.

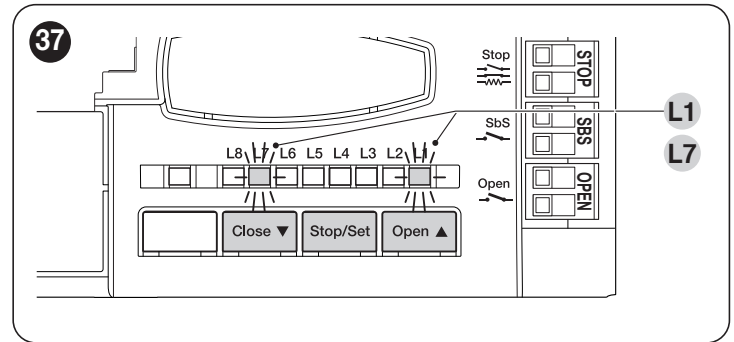

To do this:

1. press and hold the [Stop/Set] button until LED “L1” starts flashing
2. release the [Stop/Set] button when LED “L1” starts flashing
3. press the [Open ▲] or [Close ▼] button to shift the flashing LED to “L7”, that is, the “entry LED” for the “**Maintenance notice**” parameter
4. press and hold the [Stop/Set] button. With the [Stop/Set] button pressed:
 - wait roughly 3 seconds until the LED representing the current level of the “**Maintenance notice**” parameter lights up
 - press and immediately release the [Open ▲] and [Close ▼] buttons
 - the LED corresponding to the selected level will flash several times; the number of flashes indicates the percentage of manoeuvres completed (in multiples of 10%) with respect to the set limit. For example: with the maintenance notice set to L6, namely 10,000, if the viewing LED flashes 4 times, it means that 40% of the manoeuvres has been reached (i.e. between 4,000 and 4,999 manoeuvres). The LED will not flash unless 10% of the manoeuvres have been completed.
5. release the [Stop/Set] button.

7.5 MEMORY DELETION



The procedure described below restores the control unit’s default settings. All the custom settings will be lost.

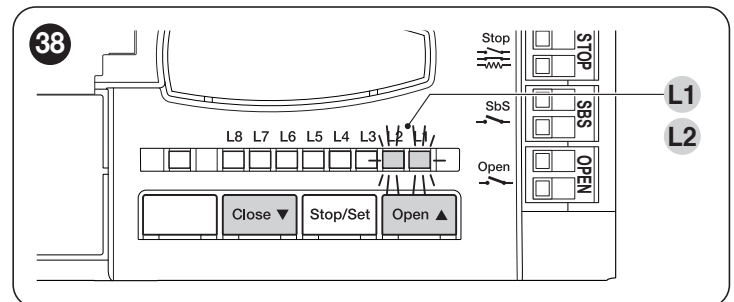

To delete the control unit’s memory and restore all the default settings, proceed as described below:

1. press and hold the [Open ▲] and [Close ▼] buttons until the programming LEDs “L1-L8” light up (after roughly 3 seconds)
2. release the buttons
3. if the operation was successful, the programming LEDs “L1-L8” flash quickly for 3 seconds.



The following will be cancelled: mechanical stop positions, Level 1 and Level 2 settings.

8.1 ANOMALY LOG

The gearmotor allows for displaying any anomalies that occurred in the last 8 manoeuvres, for example, the interruption of a manoeuvre due to the intervention of a photocell or sensitive edge.

To do this:

1. press and hold the **[Stop/Set]** button until LED "L1" starts flashing
2. release the **[Stop/Set]** button when LED "L1" starts flashing

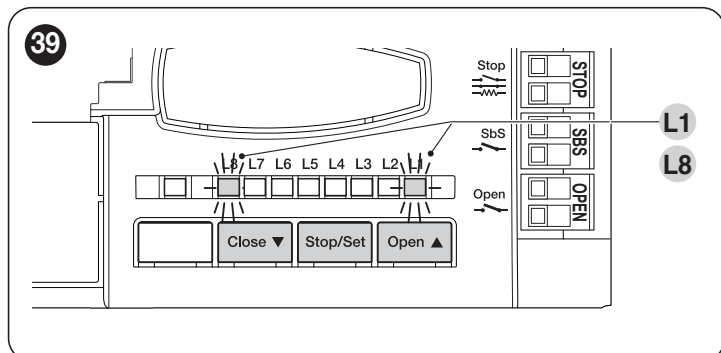

3. press the **[Open ▲]** or **[Close ▼]** button to shift the flashing LED to "L8", that is, the "entry LED" for the "List of anomalies" parameter
4. press and hold the **[Stop/Set]** button. With the **[Stop/Set]** button pressed:
 - wait roughly 3 seconds, after which the LEDs corresponding to the manoeuvres that had anomalies will light up. LED L1 indicates the result of the most recent manoeuvre, while LED L8 indicates the result of the eighth manoeuvre. If the LED is lit, it means that anomalies occurred during the manoeuvre; if the LED is off, the manoeuvre terminated without any anomalies
 - press the **[Open ▲]** or **[Close ▼]** button to select the desired manoeuvre: the corresponding LED will flash the same number of times as those emitted by the warning light following an anomaly (see "Table 8")
5. release the **[Stop/Set]** button.

8.2 SIGNALLING THROUGH WARNING LIGHT

During the manoeuvre, the "FLASH" warning light flashes once every second; whenever anomalies occur, shorter flashes are emitted; the flashes are repeated twice with a one-second pause in between.

Table 8

FLASH WARNING LIGHT SIGNALS		
Fast flashes	Cause	ACTION
1 flash 1-second pause 1 flash	BlueBus system error	At the start of the manoeuvre, the test to verify the devices connected to the BLUEBUS does not provide the same devices memorised during the learning phase. There may be defective devices: check and replace them if necessary; if changes have been made, the learning procedure must be repeated.
2 flashes 1-second pause 2 flashes	Intervention of a photocell or phototest error	At the start of the manoeuvre, one or more photocells are blocking the movement; check whether there are any obstacles. During the manoeuvre, this is normal if an obstacle is present.
3 flashes 1-second pause 3 flashes	Intervention of the "Motor Force" limiter	During the gate's movement, the motors encountered more resistance; verify the cause and increase the motor force if necessary.
4 flashes 1-second pause 4 flashes	Intervention of the STOP input	At the start of the manoeuvre or during the movement, the STOP input intervened; identify the cause.
5 flashes 1-second pause 5 flashes	Error in the internal parameters of the control unit	Wait at least 30 seconds then try giving a command; if the condition persists, it means that there is a serious malfunction and the electronic board must be replaced.
6 flashes 1-second pause 6 flashes	The maximum number of manoeuvres per hour limit has been exceeded	Wait a few minutes until the manoeuvre limiter drops below the maximum limit.
7 flashes 1-second pause 7 flashes	Error in the internal electric circuits	Disconnect all power circuits for a few seconds then try giving a command again; if the condition persists, it means that there is a serious malfunction and the electronic board must be replaced.
8 flashes 1-second pause 8 flashes	A command that prevents other commands from being executed is already present	Check the type of command that is always present; for example, it could be a command from a timer on the "Open" input.
9 flashes 1-second pause 9 flashes	The automation was stopped by a "Stop automation" command	Unlock the automation mechanism by giving the "Unlock automation" command.

8.3 SIGNALS ON THE CONTROL UNIT

The control unit has a series of LEDs, each of which can emit special signals both during regular operation and when an anomaly occurs.

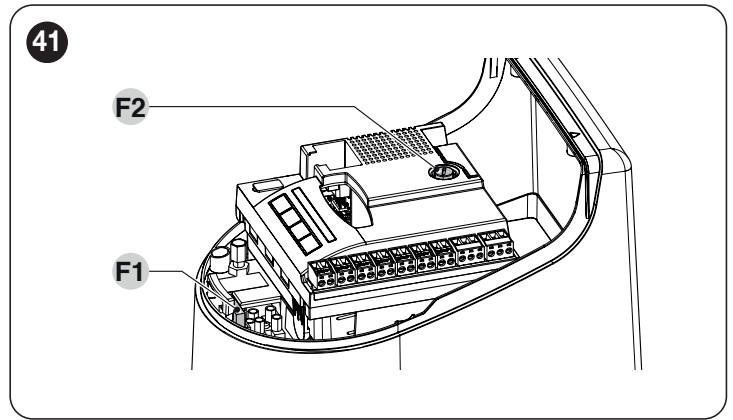
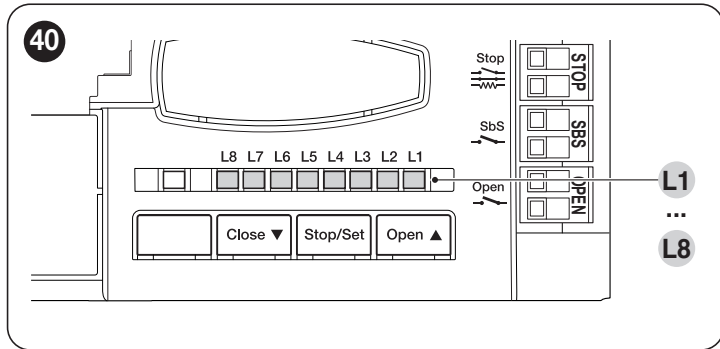



Table 9

TERMINAL LEDS ON THE CONTROL UNIT		
Status	Meaning	Possible solution
BlueBus LED		
OFF	Anomaly	Check for the presence of power; check that the fuses are not blown; if necessary, identify the cause of the fault then replace them with fuses having the same specifications.
On	Serious anomaly	There is a serious anomaly; try switching off the control unit for a few seconds; if the condition persists, it means that there is a fault and the electronic circuit board must be replaced.
1 flash per second, green color	Everything normal	Normal control unit operation.
2 rapid flashes, green color	The status of the inputs has changed	This is normal when there is a change in one of the inputs: SBS, STOP, OPEN, CLOSE, the photocells intervene or the radio transmitter is used.
Series of red flashes separated by a 1-second pause	Various	Refer to that shown in "Table 8".
1 flash per second, orange color	Everything normal	Normal operation. The control unit is awaiting the complete recharge of the connected backup battery.
STOP LED		
OFF	Intervention of the STOP input	Check the devices connected to the STOP input.
On	Everything normal	STOP input active.
SbS LED		
OFF	Everything normal	SbS input not active.
On	Intervention of the SbS input	This is normal if the device connected to the SbS input is actually active.
OPEN LED		
OFF	Everything normal	OPEN input not active.
On	Intervention of the OPEN input	This is normal if the device connected to the OPEN input is actually active
LEDs L1 - L2		
Slow flashing	Change in the number of devices connected to the BlueBus or device learning not carried out	Learn the devices (refer to the "Device learning" paragraph).
LEDs L3 - L4		
Slow flashing	The positions of the mechanical stops were never learned	Learn the mechanical stops (refer to the "Learning of the mechanical stop positions" paragraph).
LED L5		
Slow flashing	Everything normal	The EL output was associated with a function other than "electric lock" and "courtesy light".
LED L7		
Slow flashing	Everything normal	The SBS and OPEN inputs were associated with a combination of functions other than "Step-by-Step" and "Partial open 1" or "open" and "close".
LED L8		
Slow flashing	Everything normal	The FLASH output was associated with a function other than "warning light" and "open gate indicator".

9.1 ADDING OR REMOVING DEVICES

Once the automation has been assembled, it is possible to add or remove devices at any time. In particular, various types of devices can be connected to the "BlueBUS" and "STOP" inputs, as described in the following paragraphs.

 After having added or removed devices, these must be learned as described in the "Learning of other devices" paragraph.

9.1.1 BLUEBUS

BlueBUS is a technology that allows the connections of compatible devices to be made with only two conductors over which both power supply and communication signals pass. All devices are connected in parallel on the same 2 BlueBUS conductors and without the need to respect any polarity; each device is recognised individually as it is assigned a unique address during installation.

The following devices can be connected to the BlueBUS: photocells, safety devices, control buttons, signalling lights, etc. The control unit recognises all the connected devices individually through an appropriate learning phase, and can detect all possible anomalies with absolute precision. For this reason, whenever a device is connected to or removed from BlueBUS, the learning phase must be carried out on the control unit, as described in the "Learning of other devices" paragraph.

9.1.2 STOP INPUT

STOP is the input that causes immediate stoppage of the manoeuvre followed by its brief reversal. Devices with output featuring normally open "NO" and normally closed "NC" contacts, as well as devices with 8.2 kΩ fixed resistor output, such as sensitive edges, can be connected to this input.

As with the BlueBUS, the control unit recognises the type of device connected to the STOP input during the learning phase (see the "Learning of other devices" paragraph); subsequently the control unit gives a STOP command when it detects a variation with respect to the recognised status.

Multiple devices, even of different types, can be connected to the STOP input if suitable arrangements are made:

- Any number of NO devices can be connected to each other in parallel.
- Any number of NC devices can be connected to each other in series.
- Two devices with 8.2 kΩ fixed resistor output can be connected in parallel; if there are more than 2 devices then they must all be connected in cascade, with a single 8.2 kΩ terminating resistor.
- It is possible to combine two NO and NC contacts by placing them in parallel, while also mounting a 8.2 kΩ resistor in series with the NC contact (this also allows for combining 3 devices: NA, NC and 8.2 kΩ).

 If the STOP input is used to connect devices with safety functions, only those devices with 8.2 kΩ fixed resistor guarantee Category 3 safety against faults in accordance with the EN 13849-1 standard.

9.1.3 PHOTOCELLS

To allow the control unit to recognise the devices connected through the "BlueBUS" system, these devices must be addressed.

This operation can be carried out by correctly positioning the electrical jumper present in each device (also refer to the instruction manual of each device). Shown below is an addressing diagram for photocells, based on their type.

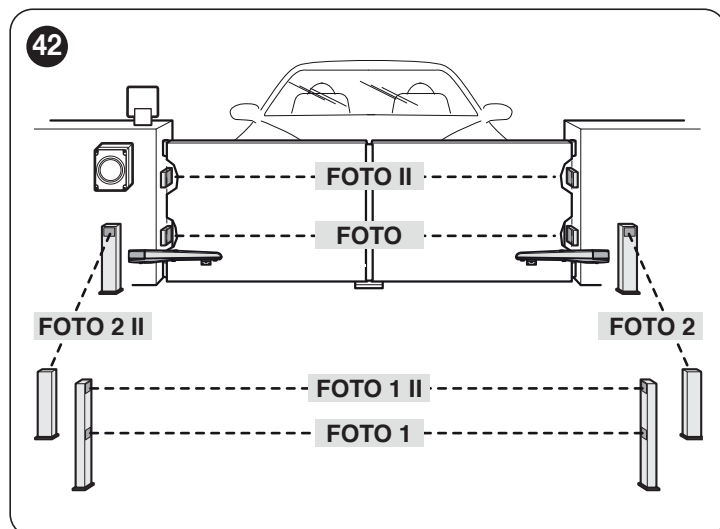



Table 10

PHOTOCCELL ADDRESSES	
Photocell	Position of the jumpers
FOTO (PHOTO) External photocell h = 50 activated during the closing phase (stops and reverses the gate's movement)	
FOTO II (PHOTO II) External photocell h = 100 activated during the closing phase (stops and reverses the gate's movement)	
FOTO 1 (PHOTO 1) Internal photocell h = 50 with intervention both in closing (stops and reverses the movement upon disengagement) and in opening (stops and restarts opening upon disengagement of the photocell)	
FOTO 1 II (PHOTO 1 II) Internal photocell h = 100 with intervention both in closing (stops and reverses the movement upon disengagement) and in opening (stops and restarts opening upon disengagement of the photocell)	
FOTO 2 (PHOTO 2) Internal photocell triggered during the opening phase (stops and reverses the gate's movement)	
FOTO 2 II (PHOTO 2 II) Internal photocell triggered during the opening phase (stops and reverses the gate's movement)	
FOTO 3 (PHOTO 3) CONFIGURATION NOT ALLOWED	

 At the end of the installation procedure, or after photocells or other devices have been removed, the learning procedure must be carried out (see paragraph "Device learning").

9.1.4 LEARNING OF OTHER DEVICES

Normally the learning of devices connected to “BlueBUS” and the “STOP” input takes place during the installation stage; however, if new devices are added or old ones removed, the learning process can be redone.

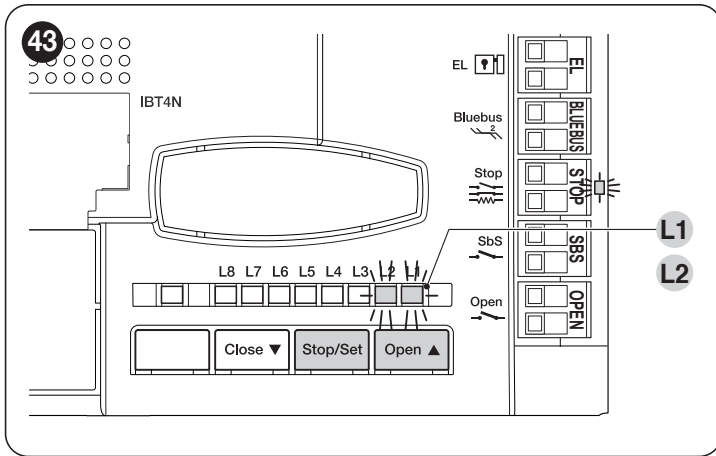

To do this:

1. simultaneously press and hold the [Open ▲] and [Stop/Set] buttons
2. release the buttons when LEDs “L1” and “L2” start flashing rapidly (after roughly 3 seconds)
3. wait a few seconds until the control unit has completed the device learning phase
4. at the end of this phase, the “Stop” LED must be lit, LEDs “L1” and “L2” must switch off, while LEDs “L1...L8” will switch on depending on the status of the ON-OFF functions they represent.



After having added or removed devices, the automation test must be carried out again as specified in the “Testing” paragraph.

9.2 CONNECTING AN OXI RADIO RECEIVER

The control unit has a slot for mounting an OXI radio receiver (version with antenna connector mounted), which can be used to remotely control the control unit through transmitters that intervene on the unit’s inputs.

To install a receiver (“Figure 44”):

1. remove the cover (A)
1. insert the receiver (B) in the appropriate slot (C) on the control unit.

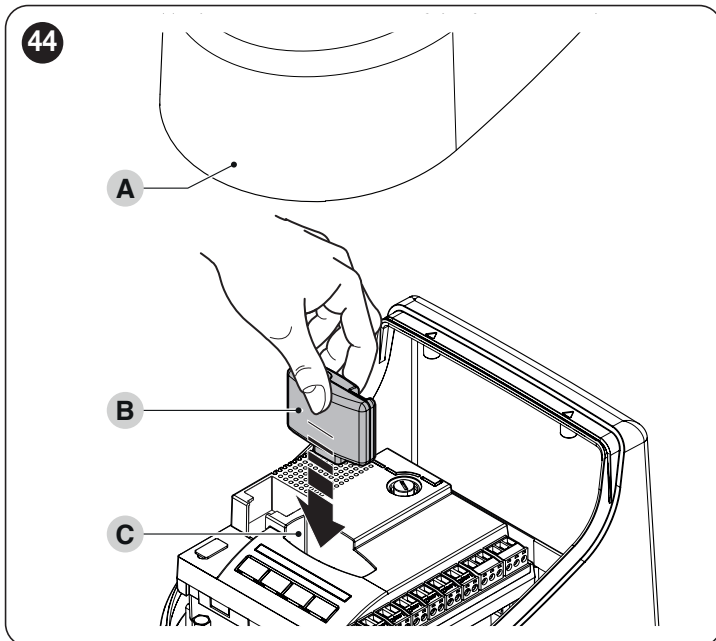

The association between the radio receiver output and the command executed by the motor is shown in “Table 11”:

Table 11

OXI IN MODE I OR MODE II	
Receiver output	Command
Output No. 1	“Step-by-Step”
Output No. 2	“Partial opening 1”
Output No. 3	“Open”
Output No. 4	“Close”

If the OXI radio receiver used in “EXTENDED MODE” is installed, it may send the commands shown in “Table 12”.

Table 12

OXI IN EXTENDED MODE II		
No.	Command	Description
1	Step-by-Step	“SbS” (Step-by-Step) command
2	Partial opening 1	“Partial opening 1” command
3	Open	“Open” command
4	Close	“Close” command
5	Stop	Stops the manoeuvre
6	Condominium Step-by-Step	Command in condominium mode
7	High priority Step-by-Step	Commands also with the automation locked or the commands enabled
8	Partial open 2	Partial opening (the M2 gate leaf opens to 1/2 the full length)
9	Partial open 3	Partial open (the two gate leaves open to 1/2 the full length)
10	Opens and locks the automation	Triggers an opening manoeuvre and, once this terminates, locks the automation; the control unit will not accept any command other than “High priority Step-by-Step” and automation “Unlock”, or (only from Oview) the following commands: “Unlock and close” and “Unlock and open”
11	Closes and locks the automation	Triggers a closing manoeuvre and, once this terminates, locks the automation; the control unit will not accept any command other than “High priority Step-by-Step” and automation “Unlock”, or (only from Oview) the following commands: “Unlock and close” and “Unlock and open”
12	Lock automation	Triggers the stoppage of the manoeuvre and locks the automation; the control unit will not accept any command other than “High priority Step-by-Step” and automation “Unlock”, or (only from Oview) the following commands: “Unlock and close” and “Unlock and open”
13	Release automation	Triggers unlocking of the automation and restores normal operation
14	On Timer Courtesy light	The courtesy light output switches on with timer-based switching off
15	On-Off Courtesy light	The courtesy light output switches on and off in Step-by-step mode



For further information, consult the specific manual of the receiver.

9.3 CONNECTING AND INSTALLING THE EMERGENCY POWER SUPPLY

This product can be equipped with an emergency power supply system that ensures operation even in the absence of mains power. The emergency power supply is through batteries that must be kept in the charged state. The battery charging function is one of the main functions of this product; the Standby Mode will be activated only when the battery charging function is completed.

Check the instructions of the emergency power system for the maximum time required for the batteries to be fully charged.

This product complies with standby regulations when connected to the battery pack PSS124. The product can recognize the charge level of the PSS124 and will recharge it correctly, avoiding entering low power mode if the battery charge level is below 80%.



WARNING

It is possible to use the previous backup battery pack PS124 by using a specific adapter cable (CABLA11) and disabling the standby mode for proper operation. In this case, the average power consumption will be increased.



The electrical connection of the battery to the control unit must be made only after completing all the installation and programming stages, as the battery is an emergency power supply.

Before installing and connecting the emergency power supply:

1. remove the cover (A)
2. connect the appropriate cable to the connector of the back-up battery (PSS124)
3. insert the relative connector (C) on the control unit.

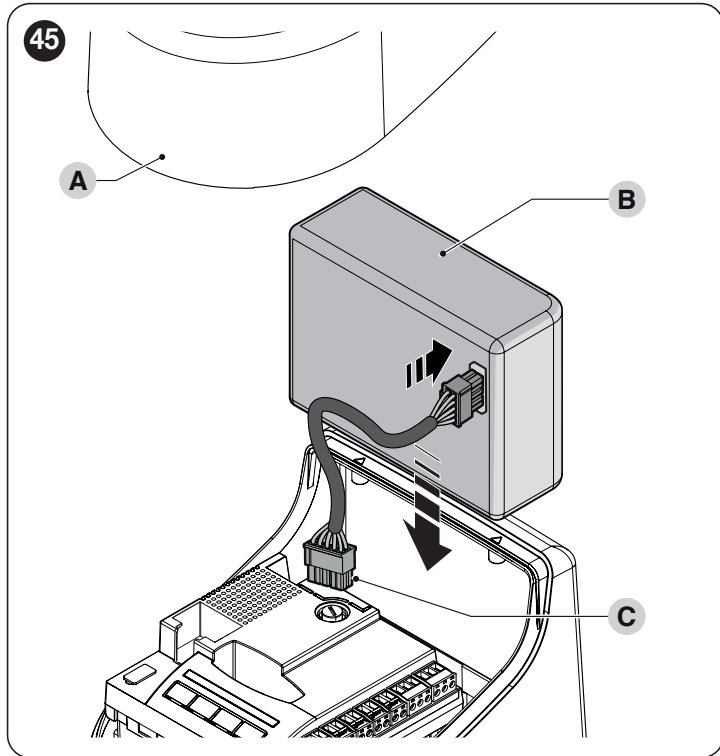

9.4 CONNECTING THE EXTERNAL UNLOCKING SYSTEM KIO



Kio must be connected to the gearmotor that drives the leaf that starts moving first (when the gate is closed).

For the connection, proceed as follows:

1. remove the cover (A) and the plastic casing (B)

46

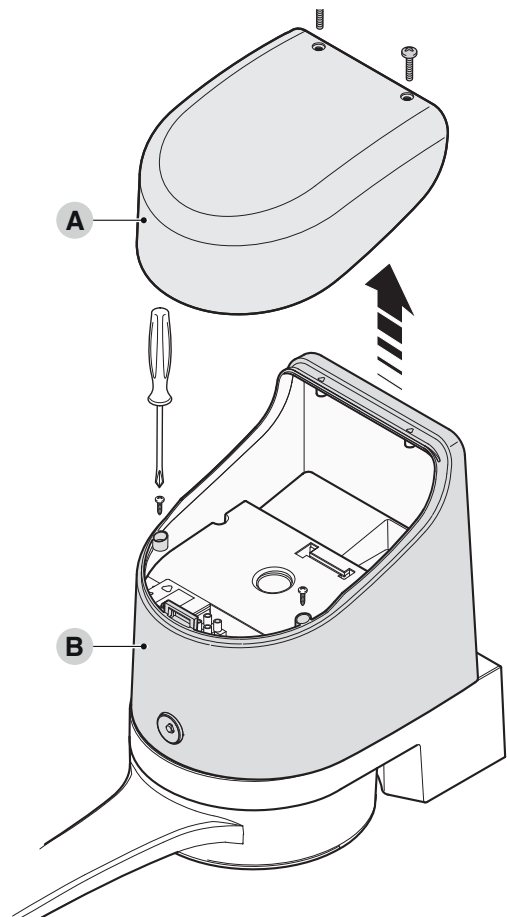

2. insert the pin (C) through the unlocking shaft hole

47

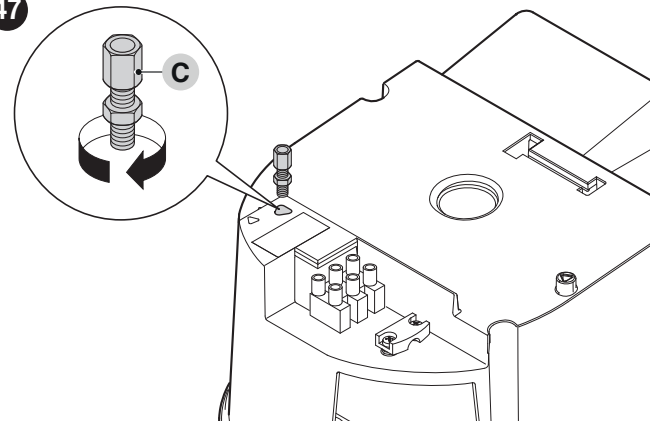

3. insert the steel cable (D) first through the screw (C), then through the appropriate hole (E) and through the pin (F)
4. lock the cable in place by tightening the pin (F)

48

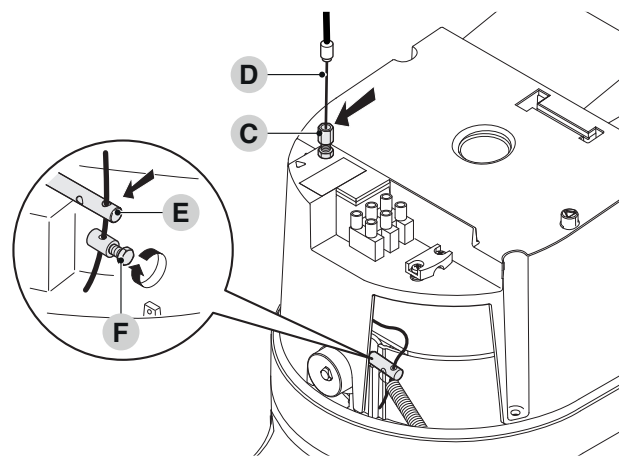

5. hook up the spring (G) by its two ends

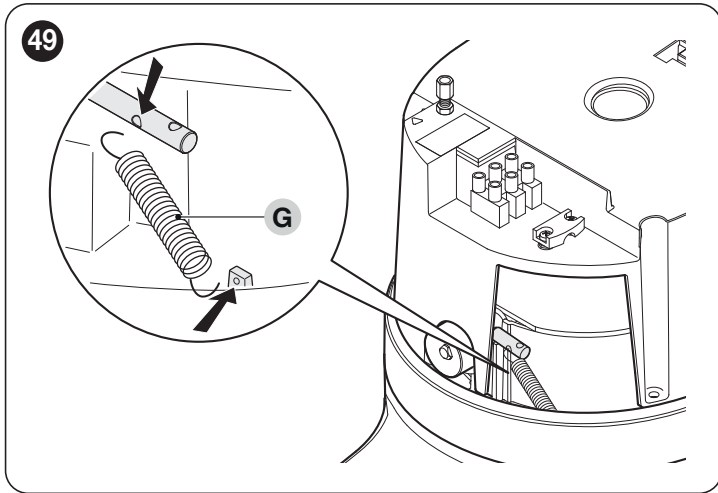

6. thread the other end of the cable through the hole located on the lower part of the gearmotor

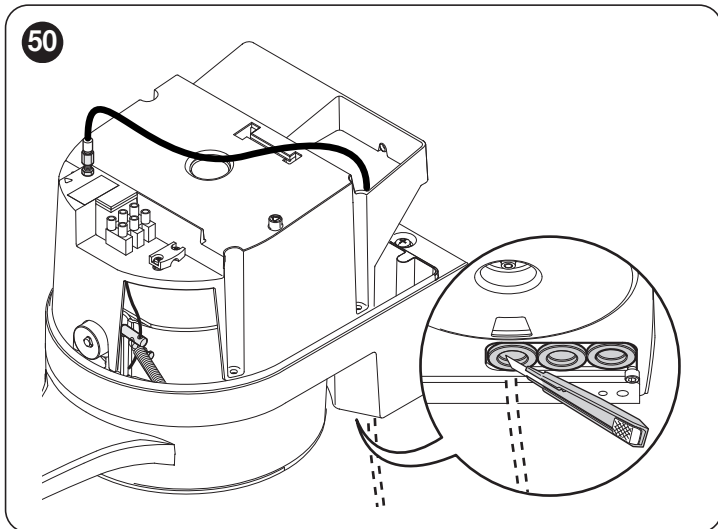

7. connect the cable to Kio, by referring to the respective instruction manual.

9.5 CONNECTING THE OVIEW PROGRAMMER

The “Oview” programming unit can be connected to the control unit. This unit allows for rapidly and fully programming the functions, adjusting the parameters, updating the control unit firmware, running the diagnostics to detect any malfunctions and performing routine maintenance. The “Oview” allows for operating on the control unit at a maximum distance of roughly 100 m. If several control units are networked with each other in a “BusT4” network, by connecting the “Oview” to one of these units, it is possible to view on the display all the networked control units (up to a maximum 16 units). The “Oview” unit can also be left connected to the control unit during normal operation of the automation, so that the user can send commands using a specific menu.

⚠ Before connecting the IBT4N interface, it is necessary to disconnect the control unit from the power supply.

To install the interface:

1. remove the cover (A)
2. place the interface (B) in the appropriate slot (C) on the control unit's electronic board
3. insert the cable (D) in the appropriate slot (E) on the interface.

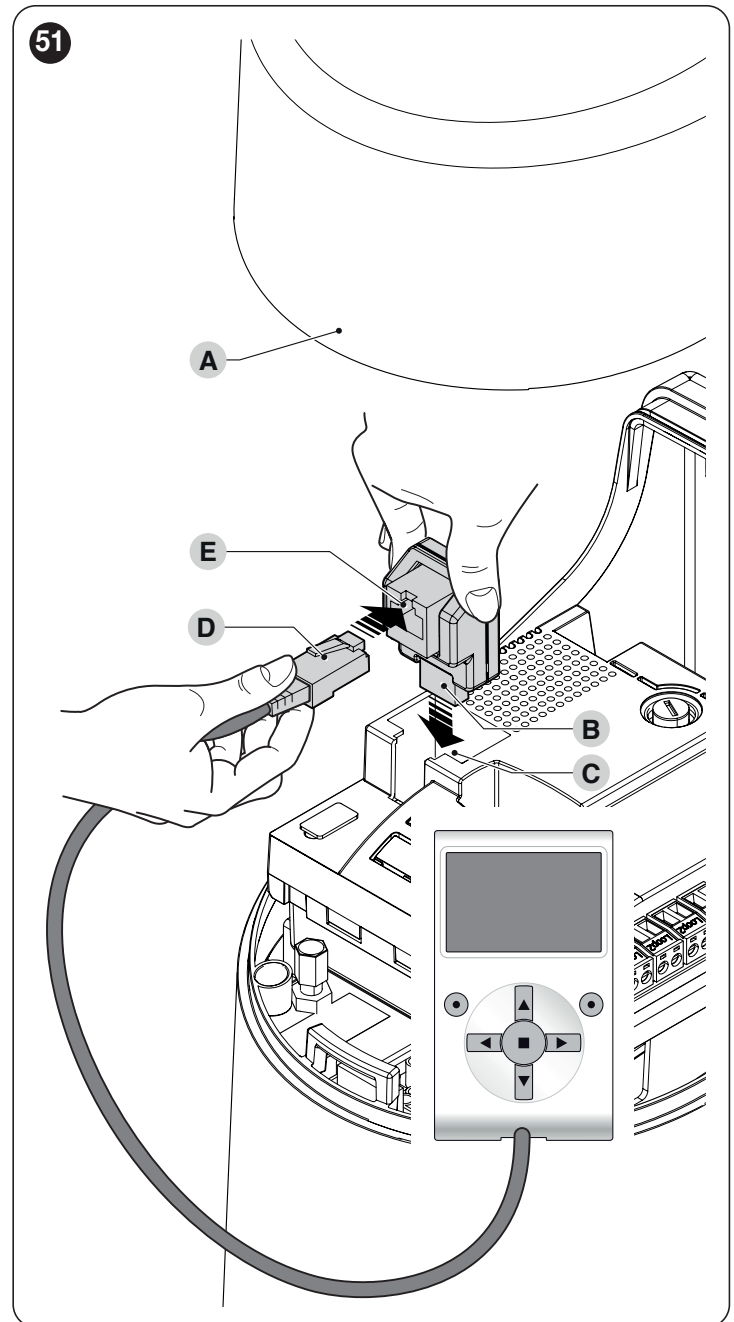

At this stage, the control unit can be powered again.



For further information, consult the specific manuals of the connected devices.

9.6 CONNECTING THE SOLEMYO SOLAR ENERGY SYSTEM



When the automation is powered by the “Solemyo” system, IT MUST NOT BE POWERED by the electricity grid at the same time.



For information on the “Solemyo” system, consult the relevant instruction manual.

To connect the “Solemyo” system:

1. remove the cover (A)
2. insert the relative connector (B) on the control unit.

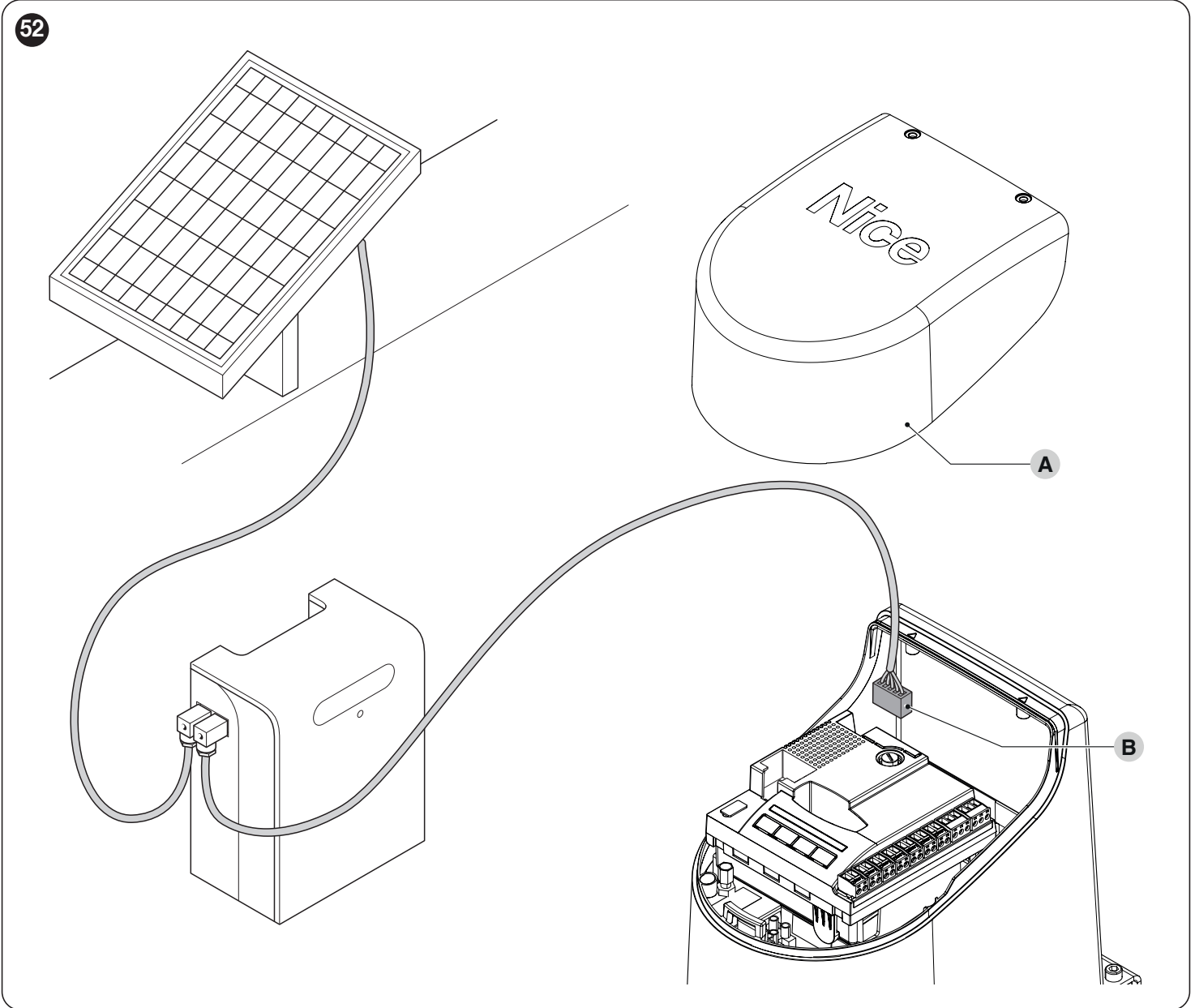

10 PRODUCT MAINTENANCE

The automation must be subjected to regular maintenance to keep its safety level constant and guarantee long-lasting operation; to this aim, **HOPP** has a manoeuvre counter and maintenance warning system; refer to the “**Maintenance notice**” function” paragraph.



Maintenance must be carried out strictly in compliance with the safety provisions provided in this manual and in accordance with the laws and regulations in force.

To carry out maintenance on the gearmotor:

1. Schedule maintenance interventions within maximum 6 months or after maximum 20.000 manoeuvres from the previous maintenance intervention
2. disconnect all power supply sources, including any emergency power supplies
3. check for any deterioration in the materials making up the automation, with special emphasis on erosion or oxidation of the structural parts; replace any parts that are not to standard
4. check the state of wear of moving parts: pinion, rack and all gate leaf components; replace any worn parts
5. connect the power supplies again and run all the tests and checks described in the “**Testing**” paragraph (page 17).

11 PRODUCT DISPOSAL



This product is an integral part of the operator and must therefore be disposed of with it.

As with the installation, only qualified personnel must dismantle the product at the end of its life.

This product is composed of different types of materials. Some of these materials can be recycled; others must be disposed of. Please enquire about the recycling or disposal systems in place in your local area for this type of product.



WARNING

Some parts of the product may contain polluting or dangerous substances. If not disposed of correctly, these substances may have a damaging effect on the environment and human health.



As indicated by the symbol shown here, this product must not be disposed of with household waste. Separate the waste for disposal and recycling, following the methods stipulated by local regulations, or return the product to the seller when purchasing a new product. If an emergency power accessory is installed in the product, it contains batteries that must be removed and disposed of according to the specific procedures for the type of battery.



WARNING

Local regulations may impose heavy penalties if this product is not disposed of in compliance with the law.

12 TECHNICAL SPECIFICATIONS



All technical specifications stated in this section refer to an ambient temperature of 20°C (± 5°C). Nice S.p.A. reserves the right to apply modifications to the product at any time when deemed necessary, without altering its functions and intended use.

Table 13

TECHNICAL SPECIFICATIONS		
Description	Technical specification	
	HO7124	HO7224
Product type	Electromechanical gearmotor for automatic gate and door systems with direct-current motor, epicyclic gear reducer and mechanical unlocking mechanism. Incorporated control unit and OXI radio receiver.	Electromechanical gearmotor for automatic gate and door systems with direct-current motor, epicyclic gear reducer and mechanical unlocking mechanism.
Peak torque [corresponding to the ability to develop a force capable of moving the leaf]	250 Nm	
Nominal torque [corresponding to the ability to develop a force capable of keeping the leaf moving]	100 Nm	
Nominal torque speed	0,13 rad/s (1,2 rpm)	
No-load speed (the control unit allow for programming 6 speeds roughly equal to: 100, 85, 70, 55, 45, 30%)	0,17 rad/s (1,6 rpm)	
Maximum frequency of operating cycles (at nominal torque)*	35 cycles/hour	
Maximum continuous operating time (at nominal torque)**	10 minutes	
Application limits	The product can be used on gates with leaves weighing up to 250 kg for lengths up to 1,5 m and with weight up to 160 kg for lengths up to 2,4 m	
Durability	Estimated between 80,000 and 250,000 cycles, depending on the conditions specified in the “ Product durability ” paragraph.	
Power supply	230V~ (120V~ for version HO7124/V1 or 250V~ for version HO7124/AU01) (±10%) 50/60 Hz	24V= (±25%)
Emergency power supply	With optional accessory PSS124	-
Solar panel power supply	Configuration for SYKCE kit	-
Maximum power draw at nominal torque	170W	50W
Peak power	280W	100W
Nominal current draw	0,8 A (1,6 A for version HO7124/V1)	2 A
Maximum current draw	1,3 A (2,6 A for version HO7124/V1)	4 A (for maximum 1 s)
Power draw in “Stand-by-All” mode with power supply from PSS124 or SYKCE kit (including OXI receiver)	Below 100 mW	-
Standby all (W)	< 0,25	-
Warning light output***	One ELB (lamp 12 V=, 21 W) or ELDC warning light	-
Electric lock output***	One 12 V~ max 15 VA electric lock	-
BLUEBUS output	One output with maximum load of 12 Bluebus units (maximum 6 pairs of EPM photocells plus 2 pairs of EPM photocells addressed as opening devices plus maximum 4 EDSB or ETPB control devices)	-
STOP input	For normally closed or normally open contacts or for 8.2 kΩ fixed resistor contacts with self-learning (any variation from the memorised status triggers the STOP command)	-
Sbs input	For normally open contacts (closing of the contact triggers the STEP-BY-STEP command)	-
OPEN input	For normally open contacts (closing of the contact triggers the PARTIAL OPEN 1 command)	-

TECHNICAL SPECIFICATIONS

Description	Technical specification	
	HO7124	HO7224
Radio receiver	OXI (version with antenna connector mounted)	-
Programmable functions	8 ON-OFF functions and 8 adjustable functions (see " Level 1 programming (ON-OFF) " paragraph)	-
Self-learning functions	Self-learning of the devices connected to the BlueBus output Self-learning of the type of "STOP" device (Normally Open, Normally Closed contact or 8.2 kΩ resistor) Self-learning of the gate path and automatic calculation of the slowdown and partial opening points. Self-learning of the operation with one or two motors.	-
Assembly	Vertical, with a dedicated fixing plate	
Operating temperature	-20°C ÷ 55°C (at low temperatures, the gearmotor's efficiency decreases)	
Use in highly acid, saline or potentially explosive atmosphere	No	
Protection rating	IP 54 (with container intact)	
Dimensions	180x252xh290h	
Weight	9 kg	6,5 kg

* Frequency of cycles at the maximum temperature: 25 cycles/hour

** Maximum continuous cycle time at the maximum temperature: 8 minutes

*** The "Warning light" and "Electric lock" outputs can be programmed with other functions (see paragraph "**Level 1 programming (ON-OFF)**"), or paragraph "**Connecting the Oview programmer**"). The electrical characteristics of the outputs can be adapted on the basis of the type of chosen function: warning light function: 12 V_{DC}, 21 W max lamp; electric lock function: 12 V_{AC}, 15 VA max; other outputs (all types): 1 lamp or relay 24 V_{DC} (-30 e +50%), 4 W max.

**WARNING**

In the instruction manual, all references to a mains voltage of 230 V must be treated as a mains voltage of 250 V for the model HO7124/AU01.

EU Declaration of Conformity and declaration of incorporation of “partly completed machinery”

Nice S.p.A., the manufacturer of this equipment, declares that it complies with Directive 2014/30/EU (EMC) and Directive 2006/42/EC (Machinery) according to Annex II, Part 1, Section B. The instruction manual and the full text of the EU Declaration of Conformity are available at the following Internet address: www.niceforyou.com; under ‘support’ and ‘download’.

Nice		Type	HO7124
Made in Italy		P/N: HO7124R30	
Nice SpA Via Callalta, 13 1046 Oderzo TV Italy			
100Nm	170W	230V 50/60Hz	
10min	-20°C	+50°C	
IP54	0.13-0.16rad/s		
S/N numero_seriale_linea			
CE		UK	
		CA	

ES264000

Note: The labels shown are a copy of the product label updated as of the publication date of this manual.

NOTES

A series of horizontal dashed lines for writing notes.

Before using the automation system for the first time, ask the installer to explain the origin of residual risks and take a few minutes and read this instructions manual and related warnings handed to you by the installer. Keep the manual for consultation when in doubt and ensure supply to new owners of the automation.



WARNING!

Your automation is a machine that faithfully executes commands imparted by the user. Negligence and improper use may lead to dangerous situations:

- do not manoeuvre the gate if there are people, animals or objects within its range of operation
- it is strictly forbidden to touch parts of the automation while it is moving
- the photocells should not be regarded as actual safety devices but only as auxiliary safety devices. They are designed using highly reliable technology, but in extreme conditions may be subject to malfunctions or potential faults, and in certain cases these faults might not be immediately evident
- periodically check that the photocells work properly.



IT IS STRICTLY FORBIDDEN to transit while the automation is closing! Transit is allowed only if the automation is fully open and stationary.



CHILDREN

An automation system guarantees a high degree of safety. With its detection systems, it can control and guarantee the gate's movement in the presence of people or objects. It is nonetheless advisable to forbid children from playing near the automation and not to leave remote controls near them to prevent any unwanted activation of the system. The automation is not a toy!

The product is not intended for use by persons, including children, with limited physical, sensory or mental capacities, or who lack experience or knowledge, unless supervised or trained in the use of the product by a person responsible for their safety.

Anomalies: if the automation shows any signs of anomalous behaviour, disconnect the power supply to the system and manually unlock the motor (see instructions at the end of the chapter) to manoeuvre the automation manually. Do not attempt any repairs personally, but contact your trusted installer.



Do not modify the system or the programming and adjustment parameters of the control unit: your installer is exclusively responsible for these operations.

Failure or lack of power supply: while waiting for the installer to intervene or the electricity to be restored, if the system is not equipped with emergency power supplies, the automation can nonetheless be used by manually unlocking the motor (see the instructions at the end of the chapter) and moving the automation manually.

Safety devices out of order: the automation can also be used when one or more safety devices are defective or out of order. The automation can be controlled in "Hold-to-run" mode in the following way:

1. send a command to operate the automation using a transmitter or key selector, etc. If everything works normally, the automation will move regularly, otherwise the warning light will flash a few times and the manoeuvre will not start (the number of flashes depends on the reason for which the manoeuvre cannot start)
2. in this case, within 3 seconds press the control again and hold it down
3. after roughly 2 seconds, the automation will complete the requested manoeuvre in "Hold-to-run" mode, in other words, it will continue to move so long as the control is held down.



If the safety devices are out of order, have the system repaired as soon as possible by a qualified technician.

The test, periodic maintenance and any repairs must be documented by the person carrying out the work and the documents must be stored by the owner of the automation. The only interventions the user may carry out periodically include cleaning of the photocell glass components (use a soft and slightly damp cloth) and removing any leaves or stones that may obstruct the automation.



Before carrying out any maintenance operations, the user of the automation must manually unlock the motor to prevent anyone from accidentally triggering the automation's movement (see the instructions at the end of the chapter).

Maintenance: in order to ensure constant levels of safety and the longest useful life for the automation, routine maintenance must be carried out (at least every 6 months).



Only qualified personnel is authorised to carry out checks, maintenance operations and repairs.

Disposal: at the end of its useful life, the automation must be dismantled by qualified personnel and the materials must be recycled or disposed of in compliance with the local regulations in force.

Replacing the remote control battery: if your remote control appears to be working poorly after some time, or stops working altogether, it may simply depend on flat batteries (depending on how much the device is used, the batteries may last from several months to over a year). You will notice this by the fact that the indicator light signalling the transmission fails to light up, is weak or lights up only for a short time. Before contacting the installer, try replacing the battery with that of another transmitter that works properly: if the anomaly is resolved, simply replace the flat battery with one of the same type.

Unlocking and manual movement

⚠ The gate can only be unlocked once the leaf has come to a standstill.

To unlock the device:

1. insert the key (A) and turn it clockwise by 180°

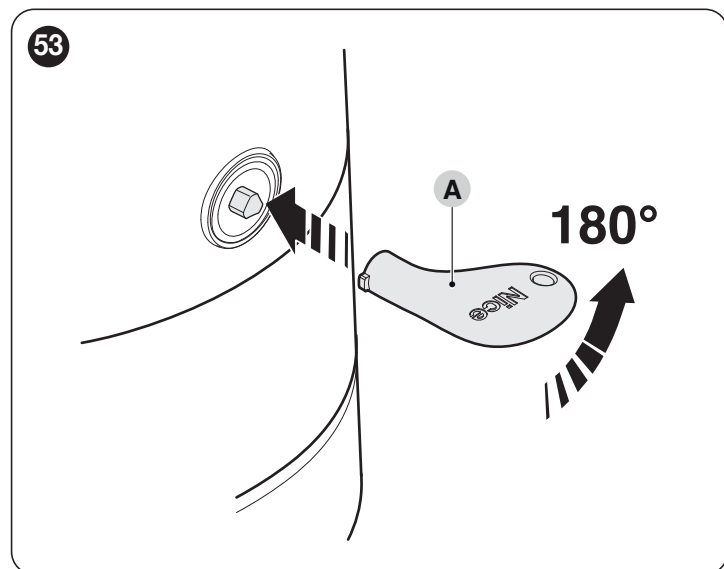

2. the gate leaf can now be moved manually to the desired position.

To lock the device:

1. turn the key (A) clockwise by 180°
2. remove the key.



Nice SpA
Via Callalta, 1
31046 Oderzo TV Italy
info@niceforyou.com

www.niceforyou.com

IS0657A02EN_22-04-2026